

ZYGGOT THERMOGRAPHY

TEMPERATURE +ARC FLASH MONITORING SYSTEM



DESCRIPTION

Varixx was the world's first company to introduce a Continuous, Online, Networked Temperature Monitoring System in 2008 and is a market leader in this area. The low-cost ZYGGOT system was designed to allow online monitoring of the temperatures of low and medium voltage components and internal connections, transformers, motors, etc., replacing old methods of periodic thermography with cameras.

The ZYGGOT system introduced an important innovation to the market because current safety standards prohibit the opening of energized electrical panels for any type of measurement, including temperature measurements with manual point-of-care guns or thermography cameras, without the use of appropriate protective clothing.

An important feature of the ZYGGOT system is that it simultaneously measures both the target and the sensor body, which is equal to the temperature of the surrounding air.

This feature also allows the detection of an increase in the internal temperature of the panel, which can identify obstructions or ventilation failures or even an increase in the temperature of equipment not directly monitored.

Sensors with opening angles of 7° allow the monitoring of both well-defined points (points) and areas of any size, depending on the distance from the sensor to the area.

Varixx also introduced the world's first and only Ultraviolet arc detection system in 2014, which does not require confirmation of current rise and inhibits arc formation at its onset due to its extremely fast action (<250 μs), detecting the arc in its initial phase and not in the fourth phase of the arc, already formed, thereby reducing the Incident Energy by around 80 to 150 times compared to the competition. It is a system that has already been widely approved, with hundreds of real cases of detection and action, with minimal or no damage to the protected systems, with a return to operation time of minutes to a few hours.

Furthermore, as it does not require current monitoring, it is very easy to implement and costs much less than light and current detection

systems.

In addition to the independent CTM and Arc Flash systems, which continue in the product portfolio, Varixx is introducing the integrated Continuous Temperature Monitoring + Arc Flash system, which saves panel door space and facilitates integration with the user's DCS system, featuring Modbus and Ethernet communication.



Gateway

Sensor UVB



Sensor UVA



Sensor Tubular



Sensor UV Octagonal



Sensor BT



APPLICATION

On-line temperature monitoring and protection of electrical connections and components for low and medium voltage electrical panels, transformers, motors, brakes, processes, etc., and integrated protection against electric arcs (Arc Flash).

BENEFITS

- * Prevents opening of the energized panel.
- * Dispenses with periodic thermography.
- * Provides target and internal air readings.
- * Non-contact measurement.
- * Arc detection in phase 1 (pre-arc).
- * Reduction in incident energy between 80 and 150 times compared to the competition.
- * Indicates any sensor failure.
- * Failure history.
- * Modbus and Ethernet communication

System Features

- * Applicable in low and medium voltage.
- * Up to 100 non-contact temperature sensors and 100 UV arc sensors in RS485 network with mini USB connections.
- * Smart Sensors powered by the network itself.
- * Measuring angle of 7° for temperature and 90° for Arc.
- * Continuous temperature readings.
- * Relay with color graphic touch screen display and Modbus and Ethernet communication.
- * Fault history with "Time Stamp".
- * Reading and over-temperature protection of up to 100 point or area targets in addition to 100 body/air temperatures.
- * Arc Flash protection with up to 40 triggering Gateways, each with up to 100 sensors for Ultraviolet detection.
- * Readings and protections related to 4 analog inputs.
- * External fault monitoring.
- * Sensor status monitoring.
- * 4 programmable digital outputs.
- * Each sensor has a flashing LED and can be controlled by the relay to facilitate its location and address on the network.
- * Operation in «Fail Safe» mode
- * Ethernet protocols:
 - TCP/IP (Modbus Slave): Modbus over Ethernet.
 - Ethernet/IP: ODVA CIP over Ethernet.
 - FTP: (File Server) File Transfer Protocol.
 - ASCII over TCP/IP: ASCII Data over Ethernet.
 - NTP Protocol: Network Time Protocol HTTP (Web Server): Hypertext Transfer Protocol (Web Server).

KEY POINTS

MAIN ADVANTAGES

TESTABLE WITH SYSTEM OFF

WITH ETHERNET

INTEGRATES ARC PROTECTION

WORLD'S MOST ADVANCED ARC PROTECTION

HIGH SELECTIVITY FOR ARC (VERSION MULTI GATEWAY)

ARC ACTUATION IN LESS THAN 250uS

REDUCES INCIDENT ENERGY BY UP TO 150X

DISPENSES CURRENT MEASUREMENT FOR ARC

DOES NOT NEED CONVENTIONAL THERMOGRAPHY

CAN MEASURE NON-VISIBLE POINTS

MEASUREMENT WITHOUT ELECTRICAL CONTACT

DOES NOT USE BATTERIES

INDIRECTLY MEASURES THE ENTIRE SYSTEM (AIR)

PROVEN RELIABILITY

HISTORY OF EVENTS

TEMPERATURE PLOT

WORLD LEADING SYSTEM

The ZYGGOT system with stainless steel tubular sensors was developed for low and medium voltage panels. The THM sensors measure temperature without physical contact, by infrared detection, and allow local and online reading and protection for up to 100 targets per relay. Each sensor measures two temperature levels: the target and the air surrounding the sensor (case), allowing fault detection at unmeasured points, by indirect heating of the air. They are networked using mini USB cables, in sizes from 0.3 to 8.0 meters (supplied), which allows for quick, error-free installation without tools. The relay provides local protection and also through a supervisory system. Alarm and trip levels are freely programmable for each point. An eventual failure in one of the sensors does not interrupt the operation of the other sensors. The BT Sensor is applied in low voltage MCCs, which require a high number of sensors in a small space, in addition to demanding a low cost. Its quick-fix base can be fixed using a screw or a stainless steel strip directly to the bus to be monitored.

The Arc sensors are also connected to a CAN network to a Gateway.

KEY POINTS

- Color Touch Screen.
- Has Ethernet communication with several protocols.
- Several built-in protections.
- UV arc protection, the most advanced in the world (Patent N° PI 0903809-4).
- Reduces incident energy by up to 150 times compared to light and current detection systems.
- Does not require current measurement to confirm an arc.
- Also available is a Multi Gateways version, which allows high selectivity for arc tripping, using a low-cost triggering Gateway per cubicle or per associated circuit breaker.
- Real-time graphical recording (Plot).
- History of failures and events.
- Continuous readings of target and surrounding air temperatures.
- Modbus RTU communication (and others).
- Networks of common temperature and arc sensors.
- Integrates arc protection with continuous thermography.
- Each relay presents up to 400 continuous measurements, namely: Temperature of 100 targets, Temperature of 100 sensor bodies (surrounding air), voltage of 100 temperature sensors plus 100 arc sensors (allowing monitoring of network integrity).

APPLICATIONS

- Internal panels for online thermography (continuous temperature measurement) and arc flash protection.
- Transformer monitoring.
- Substation monitoring.

MAIN FEATURES

- Reads temperature of up to 100 targets per relay. Reads temperature from up to 100 sensors (body / surrounding air), allowing detection of temperature increases at points not directly monitored.
- Reads supply voltage from up to 200 sensors (T+A).
- Up to 100 arc sensors per relay.
- Monitors Arc Flash by UV detection.
- Dispenses with current measurement for arc confirmation.
- Actuation in less than 250uS, in the pre-arc phase, reduces incident energy by up to 150x in relation to systems by light and current detection.
- Also available is a Multi Gateways version that allows high selectivity for arcing, allowing each circuit breaker to be tripped independently of the others, using a low-cost gateway per cubicle and a single relay per system..
- Configurable alarm and trip levels for temperature.
- Real-time graphic record for temperatures.
- Detection of differential temperature increases integrated into the relay and configurable by the user.
- Fault and status history.
- Continuous readings.
- 4 analog inputs with configurable alarm and trip levels.
- 8 digital inputs for external events or faults (ventilation, doors, etc.).
- Modbus RTU + Ethernet.



HOW TO ENSURE ACCURATE READINGS ON BODIES OF LOW OR UNKNOWN EMISSIVITY.

For low emissivity bodies, such as polished copper, which has an emissivity of 0.06, it would be very difficult to obtain an accurate reading. This is not a problem for the Zyggot system, because once the Unidex tape is stuck on the area to be measured, the emissivity of the area becomes constant at 0.95. This index, once entered into the relay's memory, becomes the correction index for the measured temperature, also avoiding variations over time, which could occur with oxidation, which would increase the emissivity index. The Unidex tape, on the other hand, is stable and does not vary over time.

If all areas of interest, be it the material, copper, porcelain, PVC, etc., have the reading area covered with the Unidex tape, it is easy to see that when the equipment is started up, before putting it into operation, it can be fully calibrated in a few seconds, simply by programming all the emissivity indexes to the value of the Unidex tape, without having to calibrate different indexes for each material.

On the other hand, low-cost portable meters or even some high-cost ones do not have the possibility of calibrating the emissivity index, which is fixed at 0.95, leading to unreliable measurements. Since the Zyggot system allows calibration for each target, reliable measurements can be obtained even without the use of the Unidex tape.

TOPOLOGY DESCRIPTION.

Each sensor has an LED that flashes under relay command to facilitate diagnosis and check the addressing.

Different Alarm and Trip levels for the target and sensor body temperatures (surrounding air) allow the protection system to be optimized. Each relay can monitor up to 100 THM sensors.

The Relay automatically indicates sensors that are not responding and also checks the supply voltage level reaching each one, allowing the detection of potential problems in the network, such as cabling exceeding the permitted extension.

The THM (thermal) sensors are connected directly to the Zyggot relay through an interface (V5CON) and the ultraviolet arc sensors are connected through 1 Gateway (or more Gateways (up to 40 ZGA1R) in the Multi Gateways version, allowing selectivity never before available worldwide for tripping specific circuit breakers in each cubicle). The relay is designed to read the target and body temperature values of the sensors, arc occurrence, arc sequence, temperature and arc sensor status, as well as power and communication voltages. Four or twelve digital outputs are available. Four digital inputs and four analog inputs are also available.

The data transmission method between sensors and relay uses RS-485 physical layer communication, with all sensors connected in parallel using shielded cables with mini-USB connectors that allow for quick installation and operation without the need for any tools.

The ZYGGOT THM+ARC system relay can be connected to a communication network with a supervisory system or remote monitoring. The ZYGGOT Relay has Ethernet communication with various protocols, and can be accessed from anywhere by mobile or non-mobile devices.

ZYGGOT RELAY VZFTA.

- **Digital Outputs:** 04 Programmable.
- **Programming of parameters and values:** "On line".
- **Reading of Values:** Temperature of each target, Temperature of each sensor body (surrounding air), Supply voltage of each THM and ARCO sensor, Analog inputs.
- **Communication:** Serial RS232C and RS485 MODBUS RTU protocol for "Point to Point" connection, for use in network (Droop Out). CAN port with CsCAN Protocol or optional Devicenet.
- **Protections and Indications:** Alarm due to target over-temperature, Trip due to target over-temperature, Alarm due to differential heating of targets, Communication failure with the THM sensor network, Communication failure with each Gateway, Modbus communication failure, THM sensors not responding, Arc sensors not responding, Alarm due to over-temperature of the sensor body (surrounding air), Trip due to over-temperature of the sensor body (surrounding air), Alarm and Trip for up to 5 groups of independent sensors, Trip due to Arc Flash (arc-voltaic), Alarm due to Gateway not programmed correctly, Alarm or trip due to ARC Chain, Alarm and Trip due to external fault, Alarm and trip due to analog input levels, Fault Detection in each Gateway, Alarm due to fault related to the memory card, Active alarm screens, History screen with «Time Stamp», Bargraph with sensors being read, Alarm and trip statistics, Digital input and digital output status, Input levels Analog inputs, Temperature plot for each sensor and analog inputs, Indication of temperature differential and percentage of each sensor in relation to programmable time.
- **Fault actions:** Programmable for each fault in "None", "Log", "Alarm", "Trip".
- **Real-time clock:** Included.
- **Fault history:** with date and time.
- **Event memorization:** Unlimited events, memorized indefinitely until they are cleared with a password, for security.
- **Programmable digital outputs:** 4 on the Zyggot relay plus 8 on the optional EBLOCK module.
- **Programmable digital inputs:** 4 on the Zyggot relay plus 8 on the optional EBLOCK module.
- **Fail Safe System:** Yes
- **Memory Card:** Automatic and manual recording of temperature and arc reading data on the memory card for transfer to computers.
- **Active screens:** over 200 multiple screens.
- **Parameter programming:** By the relay itself, with passwords, by PC software (Free), by replication via memory card (program one and replicate it in all relays in the system) or by Modbus.
- **Single Gateway or Multi Gateways version:** Yes for high arc trip selectivity, can be connected to up to 40 Gateways, each with up to 100 Ultra-violet arc sensors.
- **Multi System:** Can be used only with THM sensors (temperature), only with Arc sensors or both.

TECHNOLOGY AND MAIN FEATURES OF THE ARC SYSTEM

The ZYGGOT Arc Flash Protection System, integrated in this product with the Zyggot V5FTA THM+ARC Temperature Monitoring Relay, was designed to allow full-time monitoring and protection against arc flash of low and medium voltage electrical equipment such as panels, transformers, motors and generators.

The ZYGGOT Arc Flash Protection System introduces an important innovation to the market due to the fact that it detects ultraviolet (UV) radiation from the beginning of the arc, that is, from the pilot path, in phase 1 of the arc, before the detection of light from other systems. The light phase is already the final phase of the arc, with expansion of gases and vaporization of copper and other metals. Another important advantage is that selective monitoring of ultraviolet radiation eliminates the need for simultaneous monitoring of the current to confirm the occurrence of the arc, which is required by visible light detection systems.

If ultraviolet radiation is emitted at certain levels, the system can be safely tripped. Systems that detect visible light could be activated by door openings or light entering through cracks, which requires simultaneous current monitoring to avoid undue tripping.

The ZYGGOT Arc Flash Protection System, unlike light detection systems, can be applied even under direct sunlight*, thus opening up the possibility of using it in external systems (outdoor substations, transformers, motors, etc.).

The sensors have a 90° opening angle that allows monitoring large areas and practically an entire cubicle with a single sensor, since it even detects UV reflected on the internal walls of the panel, thus detecting the start of arcs in areas not directly targeted.

The effective monitoring distances are high due to the high sensitivity of the sensors. Each arc sensor, up to 100 per relay, is connected to a high-speed CAN network and this network is connected to a triggering Gateway, which is responsible for providing the trip signal at 300 uS, regardless of the speed of the Zyggot relay on the panel port. A single gateway and Zyggot relay can monitor up to 100 arc sensors per UV (plus 100 temperature sensors in the case of this system).

The interconnection of the sensors to the detection and triggering gateway uses a high-speed CAN network with clean and efficient wiring, unlike star systems, with analog or non-analog signals, which require each sensor to be independently connected to concentrator or interface modules. The high speed of detecting the occurrence of an electric arc and sending the trip signal (300 µs) ensures safety, because in the event of an electric arc, the sooner the energy is removed from the system, the less damage will be caused by the incident energy (up to 105 times less than systems with visible light).

Even when using circuit breakers with an opening time of tens of milliseconds, the system is guaranteed to trip, even if the network interconnection cable were destroyed by the arc, because before the destruction, the signal would have already reached the relay and the circuit breaker (in dozens of real protection cases that occurred over many years of use, no system was damaged, due to the high speed of operation, inhibiting the arc and not mitigating it). Another important difference is that the transmitted signals are digital, already processed in the microprocessor sensor and transmitted by shielded cables, therefore being immune to extremely strong electromagnetic fields generated by the arc current, unlike what can occur with visible light detection systems, with photocells, which transmit an analog signal to the interface.



BENEFITS

- * Monitors ultraviolet radiation in bands A and B.
- * Detects phase 1 of the arc, before the visible light phase (i.e. expansion and destruction).
- * Dispenses with simultaneous current monitoring to configure the occurrence of an arc.
- * Sends the trip signal in less than 300 µs.
- * A single Gateway + intelligent ZYGGOT relay with latest-generation ARM CORTEX microprocessors monitors up to 100 arc sensors per gateway (+100 temperature sensors per Zyggot relay).
- * Reduction of up to 150 times in incident energy.
- * Low implementation cost.
- * High reliability.
- * Allows for high selectivity, if necessary (Multi Gateways Version).
- * "Open" system, does not depend on proprietary software, and can be interconnected to the DCS.

PHASES OF THE ARC

Pre-Arc: Ionization of the air and formation of the path for the occurrence of an electric arc. In this phase, ultraviolet light is released (0 to 1 mS). This is the phase in which the arc sensor operates.

Compression: The energy of the arc is discharged into the air contained in the room, with a consequent increase in pressure (5 to 15 ms).

Expansion: The increase in pressure caused by the previous stage activates the relief mechanism and the air begins to be expelled to the outside, reducing the internal pressure (15 to 40 ms).

Expulsion: The pressure inside the room decreases, but the hot air continues to be expelled at an approximately constant pressure. The temperature potentially increases. The expulsion of air tends to be extinguished when the room's environment reaches the temperature of the arc (40 to 60 ms);

Thermal: The arc completely affects the insulating materials. The temperature reaches thousands of degrees Celsius and the conductive and structural materials begin to melt. This phase continues until energy dissipation occurs.

MAIN SYSTEM FEATURES

- > Intelligent trigger gateway and relay (with ARM CORTEX microprocessors). Up to 100 gateways can be connected per relay.
- > Applicable in low and medium voltage.
- > High-speed CAN network for sensors.
- > Relay with Modbus RTU port for connection to PLCs.
- > Intelligent arc sensors powered by the CAN network itself.
- > 90° measuring angle.
- > Voltage and sensor status monitoring.
- > Does not require analog interfaces.
- > Gateway, sensors and relays can be configured and tested by PC with free software.
- > Allows high selectivity for tripping, using a low-cost triggering Gateway per cubicle/circuit breaker and a single Zyggot relay per system, or even dispensing with the relay (Multi Gateways Version).
- > Possibility of using only the Gateway, without the Zyggot relay, since the Gateway has Modbus communication and can be connected directly to the user's DCS system.
- > Up to 100 sensors connected to a single Gateway + Zyggot Relay. (Network with plug-in sensors).
- > Each sensor has an LED that flashes when commanded by the relay, to detect faults or their identification.
- > Trigger gateway with 3 digital outputs, one TRIP (solid state and mechanical) and two programmable.
- > Zyggot relay with 4 or 12 programmable digital outputs and 4 digital inputs for external faults, etc., in addition to 4 analog inputs.
- > Easy testing with ArcSafe hand-held tester (arc generator)

PRINCIPLE OF OPERATION OF THE ARC SYSTEM

PRINCIPLE OF OPERATION

Each sensor in the system has a high-speed, high-performance ARM CORTEX microprocessor. The firmware embedded in the sensor will operate communication and other tasks, but if an arc is detected, a high-priority interruption will occur and the arc detection data transmission routine, with the sensor number, will be immediately transmitted to the triggering Gateway and the Zyggot relay. The time from the detection of the arc by the sensor until the activation of the Gateway's TRIP output is approximately 300 μ s, activating a solid-state contact that supports 12 A continuously and up to 200 Amps peak for 5 cycles, plus a dry contact in parallel, allowing rapid actuation and a guarantee of permanence through the mechanical contact.

The Zyggot relay, with a color touch screen, has the function of acquiring data from the Gateway, without the need for speed since the trip occurs through the Gateway. After detection, the relay will show the sequence of arc occurrence, if more than one sensor is actuated.

The high-speed CAN network of arc sensors, connected to the Gateway, provides high detection speed and also the fact that the sensors detect the initial phase of the arc guarantees that even if the network cable were destroyed by the arc itself, the trip sequence will be terminated, protecting the system from catastrophic destruction (Note: in hundreds of real cases already reported by users, this has never happened. The system itself has never been destroyed, unlike light and current detection systems, which frequently suffer from this and there has also never been catastrophic destruction in real cases protected by Ultra-violet).

The system will be protected even during the LED flash time or any other communication, because the CAN protocol has communication priorities, that is, more than one or even all network elements can generate communication at the same time and the one with the highest priority for all communication of lower priority packets is served immediately. Since the arc detection data packet is the one with the highest priority, the arc detection signal will be read immediately by the intelligent Gateway. If one or more sensors detect an arc, a list of these sensors will be displayed on the Zyggot V5FTA relay or even without the relay, this list will be available to the user on the Gateway via Modbus communication (and can therefore be used with or without the Zyggot relay, and in this case the Gateway can be configured using free software available on the Varixx website).

Gateway Trip Output

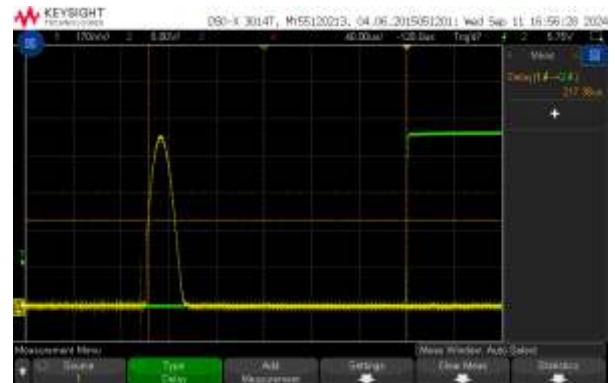

— Ocorrência do arco — Saída de trip

READING ANGLES AND REFLECTION

The sensor's opening (detection) angle defines the UV measurement area, i.e. the area where the occurrence of the arc can be detected.

UVA and UVB sensors have an opening angle of 90°, covering practically the entire area of a panel, depending on the attachment point. In a single-compartment cubicle, a single sensor installed at a suitable point, such as in one of the corners, may be sufficient.

Two sensors at opposite angles leave the entire volume without shadow areas. Ultraviolet radiation is reflected from surfaces like visible light (although it can be attenuated). Zyggot sensors can capture reflected UV radiation (depending on the reflected intensity), which facilitates detection throughout the volume of interest.

SYSTEM RELATED TO THE ARCH

- A) 90° Arc sensor - ZSA/90/24/UVA
- B) 90° Arc sensor - ZSA/90/24/UVB
- C) ZAG1R gateway
- D) V5CON Interface for Zyggot relay
- E) Zyggot V5FTA THM+ARC relay
- F) Interconnection cable with mini-USB connector - ZCB/4/2U/...
- G) 24 VDC power supply VPS12024
- H) Tester (test arc generator) ZSA
- I) Termination resistor ZFR

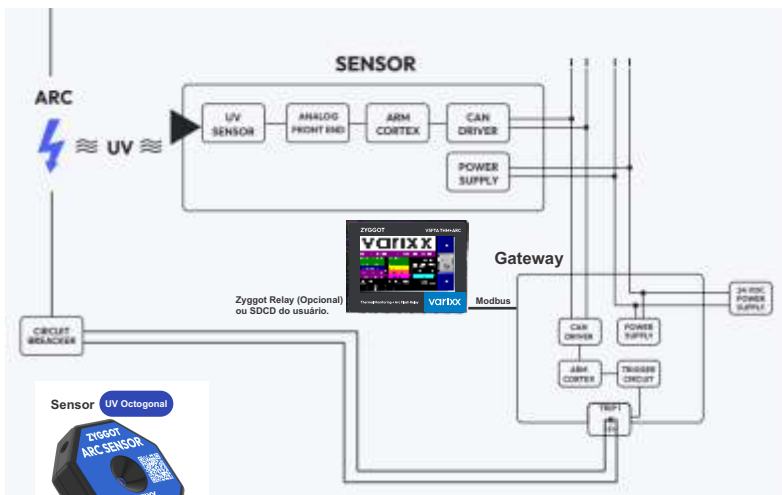

Arc Safe tester

*DEPENDE DE INTENSIDADE DO ARCO.

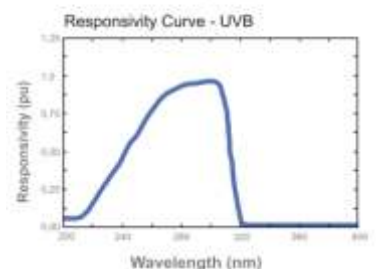
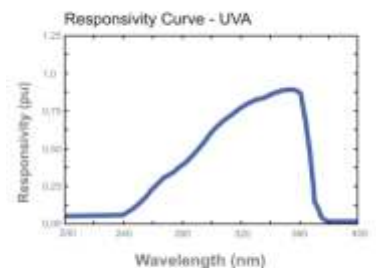

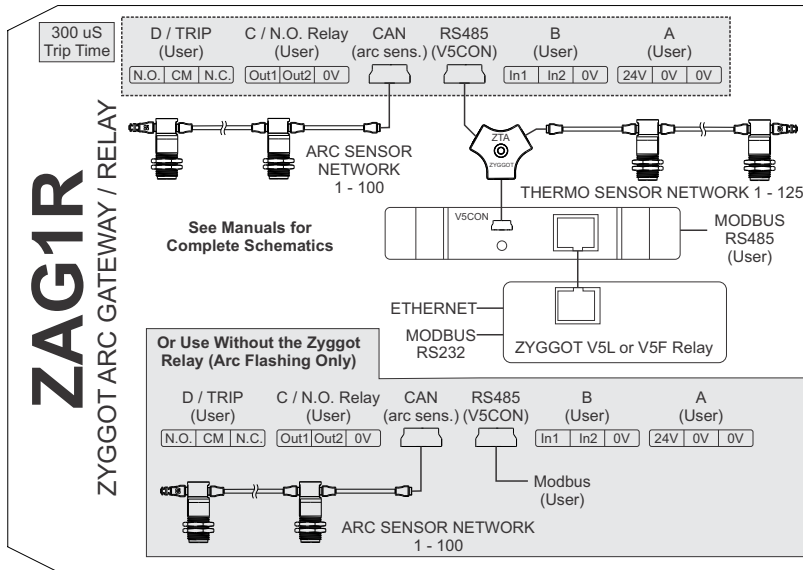
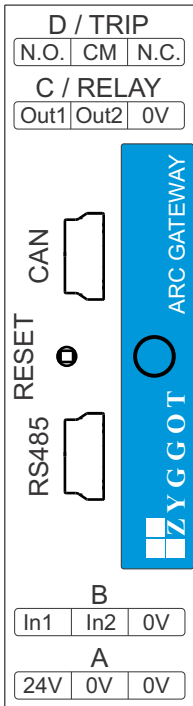

ZYGOT THM / ARC SYSTEM
Autonomous or Integrated Arc Flashing Relay
varixx
ZYGOT

ZSA/90/24/UVA Sensor Features

- > Power supply: 24VDC via standard cable.
- > Opening angle: 90°.
- > LED indicator for location and faults.
- > Network addressing configurable via PC.
- > Detects UVA radiation and a small portion of visible light (240 to 340 nm).
- > Applicable in panels and sheltered environments.
- > Does not operate with ambient light or internal light from panels. (It may operate if pointed directly at UV light sources, such as clear sky, sun, flash or intense light).
- > Sensitivity to 2 cm electric arc produced by test device at a distance of 1 to 1.5 m or real arc at up to 30 m*
- * Depends on arc intensity (with 200A and 1 cm arc path the detection distance is 7 meters)

ZSA/90/24/UVB Sensor Features

- > Power supply: 24VDC via standard cable.
- > Opening angle: 90°.
- > LED indicator for location and faults.
- > Network addressing configurable via PC.
- > Detects UVB radiation (220 to 320 nm).
- > Applicable in panels, open environments or monitoring equipment outdoors.
- > Does not operate even with strong visible light (except if pointed directly at the sun, whose rays contain UVB).
- > Sensitivity to a 2 cm electric arc produced by a test device at a distance of 0.2 m to 0.4 m or a real arc of up to 10 m*.
- * Depends on the intensity of the arc (with 200A and a 1 cm arc path, the detection distance is 3 meters).



CABLES

The ease of assembling the sensor network lies in the two mini USB connectors present on the sensors and in the shielded mini USB cables supplied in different sizes by Varixx, ready to use.

PROGRAMMING TOOLS

APC program is provided free of charge by Varixx and allows the parameterization and testing of the Gateway, Relay (which can also be programmed via the screen or online) and also the parameterization of each sensor.

GATEWAY COMMUNICATION PORT

The ZAG1R Gateway has 2 communication ports: One RS485 port with Modbus RTU protocol, for communication with supervisory systems or with Zyggot V5FTA relay or for connection to a PC for parameterization and one mini USB port with CAN protocol, for communication with networked sensors.

GATEWAY DIGITAL INPUTS

The Gateway has 2 digital inputs, 1 for Reset and 1 programmable by the relay or by the PC software. The "Reset" contact, if closed momentarily, performs the function of erasing the Gateway's alarms and trips, also erasing the Arc Flash occurrence sequence data.

DIGITAL GATEWAY OUTPUTS

The Gateway has 3 digital outputs, 1 for TRIP and 2 programmable by the relay or by the PC software. The trip output has an ultra-fast acting solid state relay and another N.A. dry contact in parallel. The programmable outputs are normally open dry contact type.

GATEWAY INDICATOR LED

The Gateway has 1 RGB LED, which will be «Green» if the gateway is programmed, configured and without alarms or trips. It will be «Yellow» in case of occurrence of alarms or trips that have not been reset or will be «Red» in case of a Trip that has not been reset.

NOTE: An alarm condition due to "Sensor not responding" or any other occurrence does not deactivate the "Armed" condition and the consequent detection in the event of an arc flash. For safety reasons, the system will be active for Arc Flash detection even in alarm.

MINI USB MULTI-FUNCTION SENSOR CONNECTOR

The mini-USB connectors on the sensor are used for both parameterization, using a standard mini USB / USB cable (supplied separately) and a PC, and for communication with the Gateway via the network cable (supplied separately). The sensor's mini USB ports are parallel, so there is no difference between which port to connect the cable to. The dual mini-USB ports make it easy to set up the network. For details on how to parameterize the sensor, see the programming section.

CAUTION

Do not connect the sensor to the computer with the other end of the sensor connected to the sensor network. This may damage the sensor and the computer!
For parameterization, one sensor per month must be connected to the computer.



Gateway

EXAMPLE OF TYPICAL APPLICATION WITH 115 VAC / 125 VDC TRIP COIL

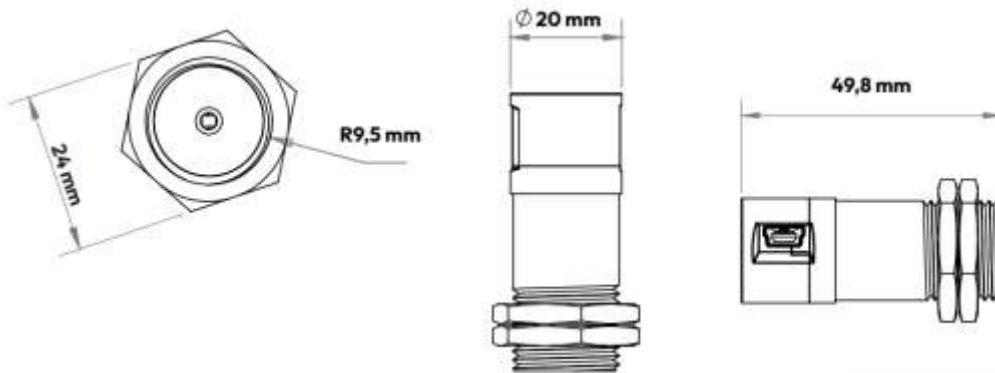
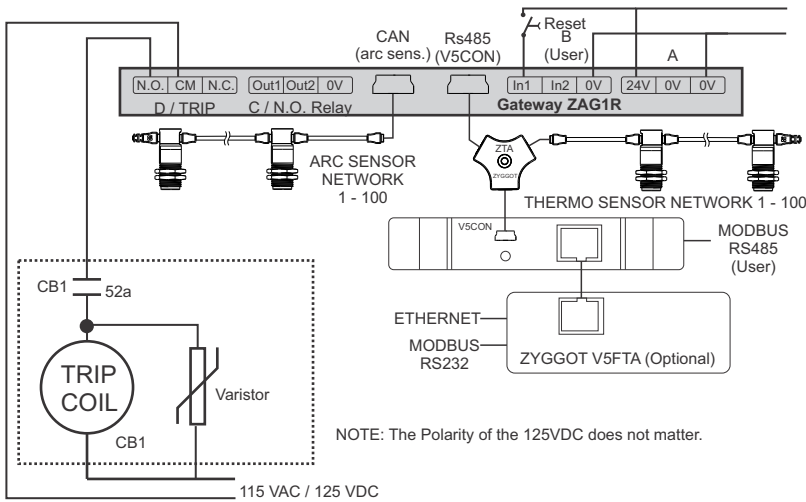

PROGRAMMING THE SENSORS

- 1 - Download and install the free software "Zyggot Arco Configurador" from the Varixx website (<http://www.varixx.com.br>).
- 2 - Open the configuration program.
- 3 - Connect the sensor to the computer's USB port using a mini USB / USB cable (connect one sensor at a time). When the sensor is connected, its back light will turn on. The program automatically detects the sensor. If this does not happen, you can choose manual connection, choose the serial port corresponding to the USB to which the sensor cable is connected and press the Connect key to attempt a connection. When connecting (in both manual and automatic mode), a green light will turn on in the program indicating that the connection was successful.
- 4 - Program the sensor address (from 1 to 100) in the corresponding window and press Send to save the information to the sensor. Disconnect the sensor by simply removing it from the cable.
- 5 - It is advisable to label the sensor with its programmed address to make it easier to assemble in the field. If you wish to configure another sensor, return to step 3. Then check that there are no duplicate addresses between the sensors.
- 6 - Once all the sensors have been programmed with the addresses, fix the sensors in the defined positions using the two nuts on the front of the sensor. As a suggested assembly, we recommend using our metal "adjustable fixing bracket" (REF. ZSF2), with adjustable angle, which allows the use of just one Boelhoff rivet or similar in the chosen location, to fix the sensor and direct it.



Ultraviolet Arc Sensor
Wide Detection Area (90°)
Detects at long distances (>7 meters
with 200 A / 1 cm arc)

IDENTIFICATION OF ARC SENSORS

When the sensors are powered on, each sensor will flash its rear LED indefinitely until the first communication with the relay occurs. This allows for a quick check of communication with the relay and sensor integrity. If in doubt, disconnect the sensor and then reconnect it. The LED should flash for a very short time and then remain on continuously. If it continues to flash, it is because it is not communicating. Check the cables, programming the sensor address and programming the number of sensors in the relay. Obviously, if the sensor is not communicating, the relay will also indicate the lack of communication.

EXAMPLE OF A TYPICAL APPLICATION USING MULTIPLE GATEWAYS AND A SINGLE RELAY

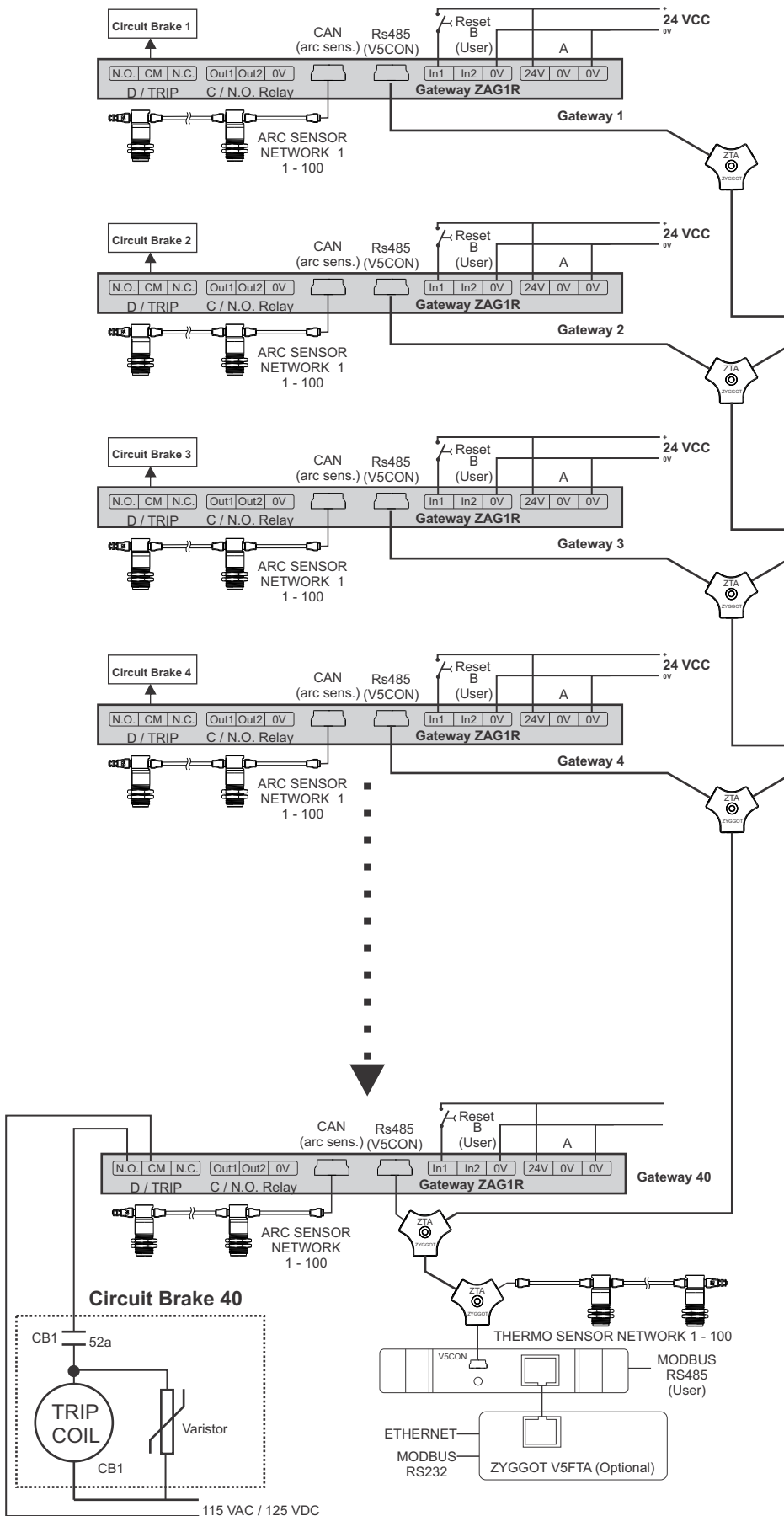

NOTE: The Polarity of the 125VDC does not matter.

In cases where high selectivity is required, such as in cases of distribution branches with one circuit breaker per branch, the side topology can be used with multiple triggering Gateways, each one triggering its own associated circuit breaker and using the relay to page information from up to 40 Gateways, each with up to 100 arc sensors, i.e. configuring a low-cost, high-efficiency system.

Even if several Gateways are associated with a single Zyggot relay, this relay can still monitor up to 100 target temperatures and up to 100 surrounding air temperatures, since the continuous temperature monitoring system is predictive, not requiring a "TRIP" but rather an "Alarm", unlike the ARC protection system where each Gateway sends the "TRIP" signal to its circuit breaker in less than 300 μ s.

EXAMPLE OF A TYPICAL APPLICATION USING ONE OR MORE GATEWAYS WITHOUT RELAY

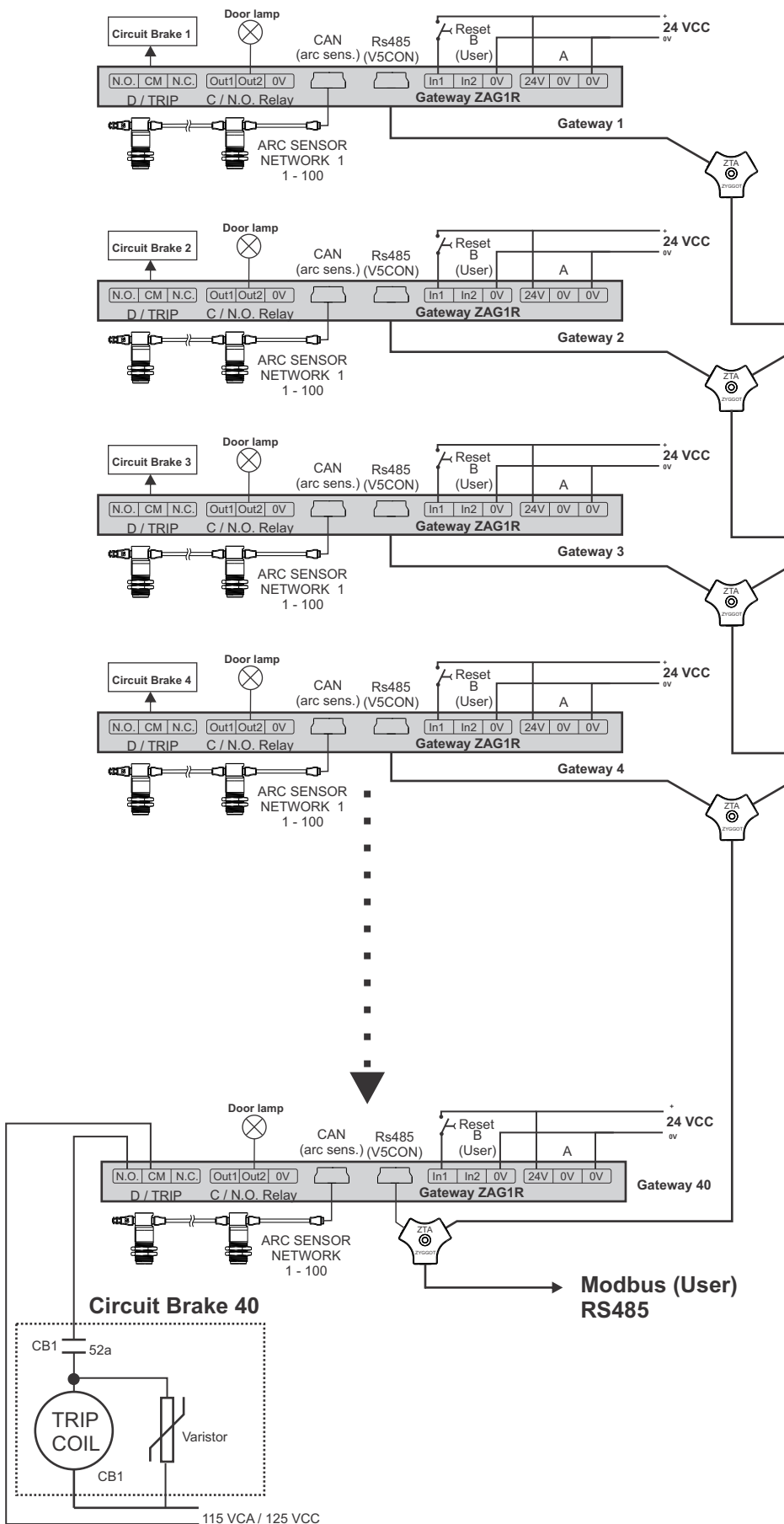

Note that it is possible to use only one Gateway with its sensors, which can be from 1 to 100, Zyggot. Typically, one Gateway per cubicle, associated with its circuit breaker, and 1 or two Zyggot UV Arc sensors would be enough to have each cubicle fully protected against Arc-voltaic.

NOTE: The Polarity of the 125 VDC does not matter.

COD: V5FTA/O or V5FTA/M



RELAY 96 X 125 Touch Screen

Technical information

FEATURES: V5FTA THM+ARC RELAY

Power Supply	24 VDC
Humidity	5 to 95%
No. of sensors	up to 100 sensors
Resolution	1°C
Inputs	4 analog 4 digital (12 to 24VDC)
Outputs	2 Alarm and Trip outputs (N.O.) 2 programmable outputs (N.O.) 1 output for connection to sensors
Communication	Modbus RTU Devicenet (optional) Ethernet TCP-IP (optional)
Screen	Color, Touch Screen WVGA

COD: V5CON
(Comes with each Relay)



INTERFACE

COD: ZST/M/7/300/24



THM TUBULAR THM SENSOR

Technical information

FEATURES: EBLOCK 88x (x=D or x=R)

Power Supply	24 VDC (10 - 30 VDC) 2W
Moisture	5 to 95%
Communication	CAN
Temperature	Oper: 0 to 60 °C /// Armaz: -10 to +60 °C
Inputs	8 Digital Inputs (12 - 24 VDC)
Outputs	Model 88D = 8 Digital Outputs (DC) Model 88R = 8 Digital Output (Relay)
Inputs	Imp.: 10K /// Treshold: 8 VDC / 3 VDC
Distance Max	1000 M
Output Current (Model 88D)	2,5 A Max per point /// 10A Total Max (model 88D)
Output (mod 88R)	3,0 A @ 250 VAC Res. Max (mod. 88R)

COD: ZAG1R



GATEWAY PARA ARCO

COD: ZSB/M/60/120



THM BT SENSOR

Technical information

FEATURES: THM TUBULAR SENSOR

Measurement angle:	7°
Typical read error (*):	+/- 0,5°C (trg: 0-125°C)
Normal Distribution (100 s):	0.48°C at 80°C target
Emissivity:	Programmable (0,95 std)
Resolution:	1°C
Target reading:	0 to 300 °C
Environment reading:	0 to 75 °C
Power:	24 Vcc
Diameter:	19 mm
Length:	53 mm
Communication:	Modbus RTU
Material:	Stainless Steel / Polycarbonate

(* See test report at the end of this manual)

Technical information

FEATURES: ARC UVA SENSOR

Measuring angle:	90°
Power Supply:	24 VCC by the NET
Detection range:	UVA (240 to 380 nm)
Test sensitivity:	1 to 1,5 m (w/tester ZSA)
Real Arc Sensitivity:	up to 30 m
LED status indicator:	Included
Settings:	By PC software
Diameter:	19mm
Length:	53mm
Communication:	Rede CAN 512 MBs
Material:	Stainless Steel and Polycarbonate

COD: ZSA/90/24/UVA



UVA TYPE ARC SENSOR

Technical information

FEATURES: BT SENSOR

Measurement angle:	120°
Typical read error (*):	+/- 0,5°C (trg: 0-125°C)
Normal Distribution (125 s):	0.48°C at 80°C target
Emissivity:	Programmable (0,95 std)
Resolution:	1°C
Target reading:	0 to 120 °C
Environment reading:	0 to 75 °C
Power:	24 Vcc
Diameter:	54 mm
Length:	31 mm
Communication:	Modbus RTU
Material:	Polycarbonate

(* See test report at the end of this manual)

Technical information

FEATURES: ARC UVB SENSOR

Measuring angle:	90°
Power Supply:	24 VCC by the NET
Detection range:	UVB (220 to 320 nm)
Test sensitivity:	1 to 1,5 m (w/tester ZSA)
Real Arc Sensitivity:	up to 30 m
LED status indicator:	Included
Settings:	By PC software
Diameter:	19mm
Length:	53mm
Communication:	Rede CAN 512 MBs
Material:	Stainless Steel and Polycarbonate

COD: ZSA/90/24/UVB



UVB TYPE ARC SENSOR

Technical information

Connectors: EB/88D & EB 88R

1:	Digital Outputs / Relay Outputs
2:	NET address selection switches
3:	LEDs de status
4:	Inputs
5:	CAN & Power Supply
6:	Ground
7:	CAN RJ45

Technical information

FEATURES: ARC UV SENSOR OCTO

Measuring angle:	90°
Power Supply:	24 VCC by the NET
Detection range:	UVA (240 to 380 nm)
Test sensitivity:	50 to 80 Cm (w/test. ZSA)
Real Arc Sensitivity:	up to 20 m
LED status indicator:	Included
Settings:	By PC software
Diameter:	19mm
Length:	53mm
Communication:	Rede CAN 512 MBs
Material:	Stainless Steel and Polycarbonate

COD: ZSA/90/24/UV/OCT



UV TYPE ARC SENSOR OCTO

ACCESSORIES

Accessory

COD: VPS6024 ou VPS12024



POWER SUPPLY

Accessory

COD: ZSF2



Support for fixing and sight for tubular

Accessory

COD: VZX/B1/U ou VZX/B1/U/P



SUITCASE WITH LASER SIGHT

Accessory

COD: ZFR COD: ZTA



COD: ZCB4/2U/xxx

Y-split Derivator, USB cables and terminating resistor

Accessory

COD: VLP2



Laser sight attachable to tubular sensor for startup

Accessory

COD: ZA232-2



SPLIT RS232

Accessory

COD: V5CON (Comes with each Relay)



INTERFACE

Accessory

COD: RJ45/C2 (Comes with each V5CON module and each Eblock)



RJ45 CABLE

COD: EB/88D ou EB/88R (For use with V5FTA relay)

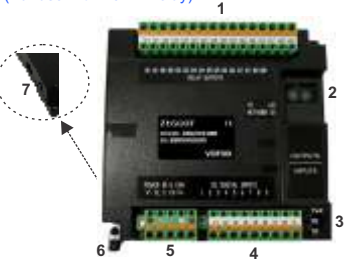

EBLOCK (Optional Use)

Included with every BT sensor

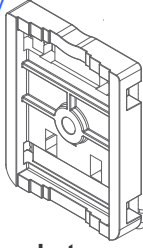

Quick Fixing Bracket for BT Sensor

COD: ZSA



ARCSAFE Arc Tester

TYPICAL CONNECTIONS (THM ONLY)

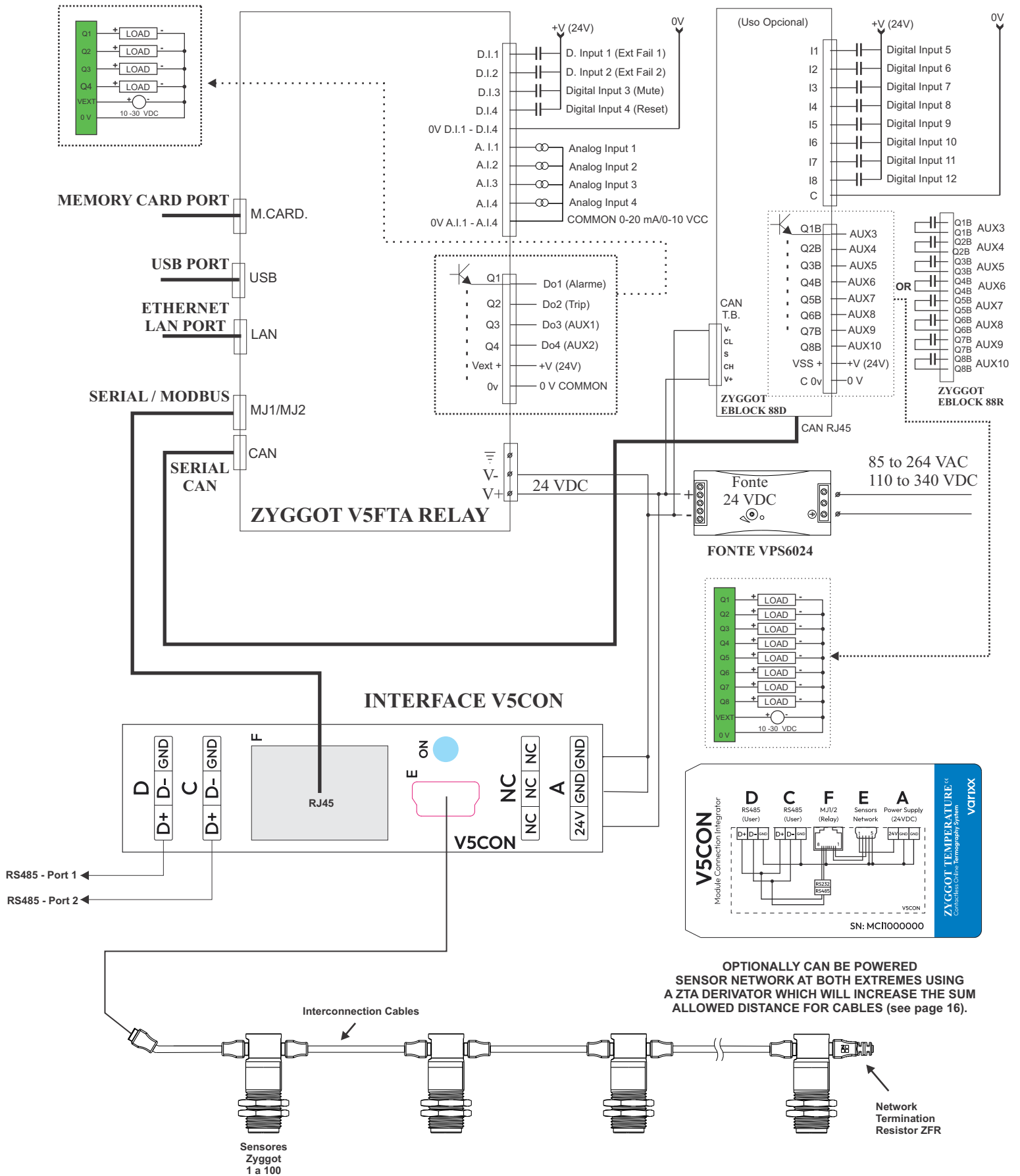

MAIN SCREENS FOR OPERATION

a- MAIN MENU, (ESC) INFO SCREENS



MAIN MENU:

Screen from which all other system screens are accessed. Depending on whether the system is configured for THM+ARC, THM only or ARC only, one of the 3 screens above will be accessed.

From here, all operating and programming screens are accessed.

Note that, to eventually draw the operator's attention, the «ALARM» field will flash and have a red border to indicate that there is an Acknowledged or Cleared alarm on the Alarm screen. By touching this field, you enter the alarm screen and can acknowledge and reset the alarm.

ATTENTION: THE ZYGGOT V5FTA RELAY LEAVES THE FACTORY WITH A PASSWORD TO ENTER THE PROGRAMMING MENU = «827499»
CHANGE IT, WITHIN THE «RELAY CONFIG» MENU TO ANY OTHER VALUE (ADVISABLE).



INFO SCREENS 1 to 5:

There are 5 screens, the one above, and the four below. They are paged through the >> and << keys and accessed through the ESC key on the main menu.

INFO SCREEN 1: Contains various information. When the system is powered on, this is the initial screen. Pressing ESC takes you to the main menu above.

VERS: Software version

THM S.COMM OK: Indicates that the THM sensor network is communicating OK.

ARC S.COMM OK: Indicates that the ARC sensor network is communicating OK.

THM S.COMM ERR: Indicates that the THM sensor network has a communication error.

LINK ETHERN.OK: Indicates that the Ethernet connection is OK.

ETHERN.n. LINKED: Indicates that the Ethernet connection is OK.

GTWY PGM: Indicates that the ARCO system Gateway is properly configured.

GTWY ARMED: Indicates that the ARC system Gateway has no active faults and is ready to "trip" in the event of an Arc or other faults.

GATEW. ALRM: Indicates that the ARC system Gateway is in an active Alarm condition (not reset).

GATEW. TRIP: Indicates that the ARC system Gateway is in an active Trip condition (not reset).

GATEW. CHAIN: Indicates that the ARC system Gateway has the Chain input active and a Chain trip has probably occurred (it depends on the Gateway configuration).

INHIBITED: Indicates that the ARC system Gateway has the INHIBIT input active and cannot trip even in the event of an ARC FLASH (it depends on the Gateway configuration).

DATE, TIME and DAY OF THE WEEK: from the internal real time clock.

FAIL: Indicates a fault that has not been reset.

TRGT: Indicates a fault related to Targets.

AIR: Indicates air-related fault (sensor bodies).

TNR: Indicates the existence of 1 or more THM sensors not responding on the network.

ARC: Indicates that there is an active arc occurrence (not reset).

ANR: Indicates the existence of 1 or more ARC sensors not responding on the network.

ALRM: Indicates the alarm condition not silenced (without Mute) and the alarm output active.

TRIP: Indicates the Trip failure condition (Trip output active, not reset)

MAIN SCREENS FOR OPERATION

2-TARGET, 3- AIR, 4- SELECTED



TARGET T01 to T17:

There are 17 screens, scrolled by the >> and << keys.
T01 to T21: Screen Index. Flashes if any of the Target values is above the set alarm value.
 °TT: Indicates °C (degrees Centigrade) or °F (degrees Fahrenheit), as programmed.
T001 to T100 (screens 1 to 17): Shows the current temperature of each target. The color will be white if within the normal range, yellow if above the programmed Alarm point and red if above the programmed Trip point. If yellow or red, it will also flash.



SELECT TARGET ST01 to ST4: SELECT AIR SA1 to SA4:

There are 8 screens, scrolled by the >> and << keys.

St01 to ST4: Screen Index. Flashes if any of the Target values, even if not selected, is above the stipulated alarm value.
T###: Sensor index, from 1 to 100, which the operator can enter by touching this key to monitor the Target Temperature. Flashes if this temperature is above the alarm level programmed for it.
####: Shows the current temperature of the selected target. The color will be white if within the normal range, yellow if above the programmed Alarm point and red if above the programmed Trip point. If yellow or red, it will also flash.
Sa01 to SA4: Screen Index. Flashes if any of the Air (Body) values, even if not selected, is above the stipulated alarm value. **A###:** Sensor index, from 1 to 100, which the operator can enter by touching this key to monitor the Air (Body) Temperature. It flashes if this temperature is above the alarm level programmed for it.
####: Shows the current temperature of the selected air. The color will be white if within the normal range, yellow if above the programmed Alarm point and red if above the programmed Trip point. If yellow or red, it will also flash.
 °TT: Indicates °C (degrees Centigrade) or °F (degrees Fahrenheit), as programmed.

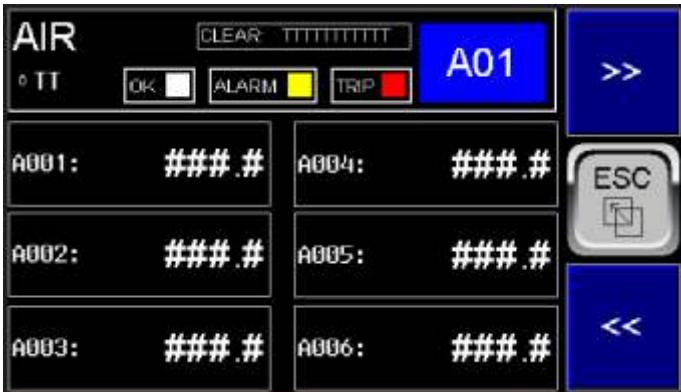

AIR T01 to T17:

There are 17 screens scrolled by the >> and << keys
A01 to A17: Screen Index. Flashes if any of the Air (Sensor Body) values are above the stipulated alarm value.
 °TT: Indicates °C (degrees Centigrade) or °F (degrees Fahrenheit), as programmed.
A001 to A100 (from screens 1 to 21): Shows the current temperature of each target. The color will be white if within the normal range, yellow if above the programmed Alarm point and red if above the programmed Trip point. If yellow or red, it will also flash.

MAIN SCREENS FOR OPERATION

5-FAILS

FAILS **MUTE ALARM** **RESET FAIL** **AF1** >>

TARGET TRIP	<input type="checkbox"/>
TARGET ALARM	<input type="checkbox"/>
AIR TRIP	<input type="checkbox"/>
AIR ALARM	<input type="checkbox"/>
THM COMM. FAIL	<input type="checkbox"/>
THM SENSOR NOT RESP.	<input type="checkbox"/>

ALARM STATE ACTIVE TRIP STATE ACTIVE
 FAIL ACTIVE ALRM UNACK ALRM UNCLEAR

ESC

<<

FAILS **MUTE ALARM** **RESET FAIL** **AF2** >>

EXTERNAL FAIL 1:	XXXXXXXX	<input type="checkbox"/>
EXTERNAL FAIL 2:	XXXXXXXX	<input type="checkbox"/>

ALARM STATE ACTIVE TRIP STATE ACTIVE
 FAIL ACTIVE ALRM UNACK ALRM UNCLEAR

ESC

<<

FAILS **MUTE ALARM** **RESET FAIL** **AF3** >>

ANALOG 1 ALARM:	XXXXXXXX	<input type="checkbox"/>
ANALOG 2 ALARM:	XXXXXXXX	<input type="checkbox"/>
ANALOG 3 ALARM:	XXXXXXXX	<input type="checkbox"/>
ANALOG 4 ALARM:	XXXXXXXX	<input type="checkbox"/>

ALARM STATE ACTIVE TRIP STATE ACTIVE
 FAIL ACTIVE ALRM UNACK ALRM UNCLEAR

ESC

<<

FAILS **MUTE ALARM** **RESET FAIL** **AF4** >>

ANALOG 1 TRIP:	XXXXXXXX	<input type="checkbox"/>
ANALOG 2 TRIP:	XXXXXXXX	<input type="checkbox"/>
ANALOG 3 TRIP:	XXXXXXXX	<input type="checkbox"/>
ANALOG 4 TRIP:	XXXXXXXX	<input type="checkbox"/>

ALARM STATE ACTIVE TRIP STATE ACTIVE
 FAIL ACTIVE ALRM UNACK ALRM UNCLEAR

ESC

<<

FAILS **MUTE ALARM** **RESET FAIL** **AF5** >>

EXCESS OPERATING HOURS	<input type="checkbox"/>
MODBUS COMM FAIL	<input type="checkbox"/>
DIFFERENTIAL ALARM	<input type="checkbox"/>
DIFFERENTIAL TRIP	<input type="checkbox"/>
ARC GATEWAY REMOTE 1 COMMAND	<input type="checkbox"/>
ARC GATEWAY REMOTE 2 COMMAND	<input type="checkbox"/>

ALARM STATE ACTIVE TRIP STATE ACTIVE
 FAIL ACTIVE ALRM UNACK ALRM UNCLEAR

ESC

<<

FAILS **MUTE ALARM** **RESET FAIL** **AF6** >>

G1 TARGET ALARM	<input type="checkbox"/>	G1 AIR ALRM	<input type="checkbox"/>
G2 TARGET ALARM	<input type="checkbox"/>	G2 AIR ALRM	<input type="checkbox"/>
G3 TARGET ALARM	<input type="checkbox"/>	G3 AIR ALRM	<input type="checkbox"/>
G4 TARGET ALARM	<input type="checkbox"/>	G4 AIR ALRM	<input type="checkbox"/>
G5 TARGET ALARM	<input type="checkbox"/>	G5 AIR ALRM	<input type="checkbox"/>

ALARM STATE ACTIVE TRIP STATE ACTIVE
 FAIL ACTIVE ALRM UNACK ALRM UNCLEAR

ESC

<<

FAILS **MUTE ALARM** **RESET FAIL** **AF7** >>

G1 TARGET TRIP	<input type="checkbox"/>	G1 AIR TRIP	<input type="checkbox"/>
G2 TARGET TRIP	<input type="checkbox"/>	G2 AIR TRIP	<input type="checkbox"/>
G3 TARGET TRIP	<input type="checkbox"/>	G3 AIR TRIP	<input type="checkbox"/>
G4 TARGET TRIP	<input type="checkbox"/>	G4 AIR TRIP	<input type="checkbox"/>
G5 TARGET TRIP	<input type="checkbox"/>	G5 AIR TRIP	<input type="checkbox"/>

ALARM STATE ACTIVE TRIP STATE ACTIVE
 FAIL ACTIVE ALRM UNACK ALRM UNCLEAR

ESC

<<

FAILS **MUTE ALARM** **RESET FAIL** **AF8** >>

STOPPED ON GATEWAY: ###

GATEWAY NOT PROGRAMMED	<input type="checkbox"/>
ARC GATEWAY COMM FAIL	<input type="checkbox"/>
ARC SENSOR NOT RESP.	<input type="checkbox"/>
ARC FLASH ALARM	<input type="checkbox"/>
ARC FLASH TRIP	<input type="checkbox"/>
ARC CHAIN	<input type="checkbox"/>

ALARM STATE ACTIVE TRIP STATE ACTIVE
 FAIL ACTIVE ALRM UNACK ALRM UNCLEAR

ESC

<<

FAILS AF1 to AF8:

There are 8 screens scrolled by the >> and << keys.

They indicate the memorized faults (active or not at the moment) if selected in the programming menu for LOG, ALARM or TRIP. They are self-explanatory.

The Mute Alarm and Reset Fail buttons on each screen allow you to silence the alarm (digital alarm output) or Reset the fault, respectively. Note that to reset the fault you must first perform the Mute and also that the fault no longer exists if the 'Reset On Fail' parameter is not enabled in the Programming menu.

They also show the conditions: Alarm State Active and Trip State Output.

Fail Active, Alarm Unacknowledged and Alarm Uncleared: as detailed in screen Ms1.

MAIN SCREENS FOR OPERATION

8-TARGET ALRM, 9- TARGET TRIP, 10- AIR ALARM, 11- AIR TRIP

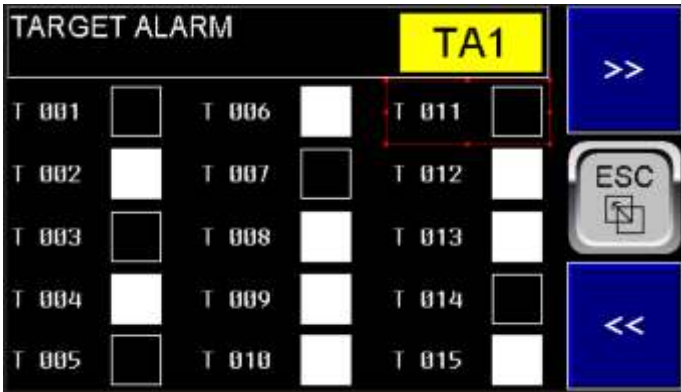

TARGET ALARM TA1 to TA9:

There are 7 screens, scrolled by the >> and << keys.
 Ta1 to TA7: Screen Index. Flashes if any of the Target values is above the programmed alarm value.
 T001 to T100 (from screens TA1 to TA7): Indicates whether the temperature of each Target is above the programmed alarm value.

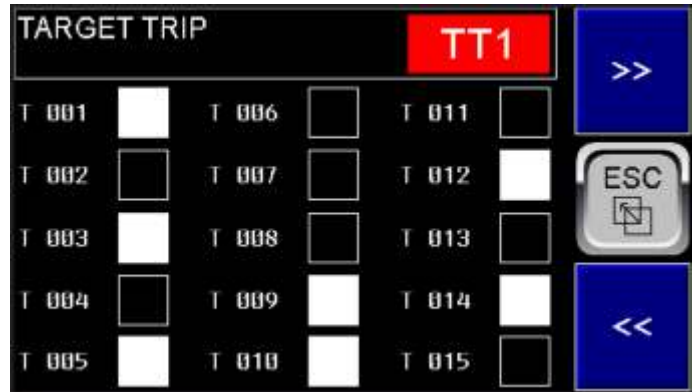

TARGET TRIP TT1 to TT9:

There are 7 screens scrolled by the >> and << keys.
 Tt1 to TT7: Screen Index. Flashes if any of the Target values is above the value programmed for Trip.
 T001 to T100 (from screens TA1 to TA7): Indicates whether the temperature of each Target is above the value programmed for Trip.

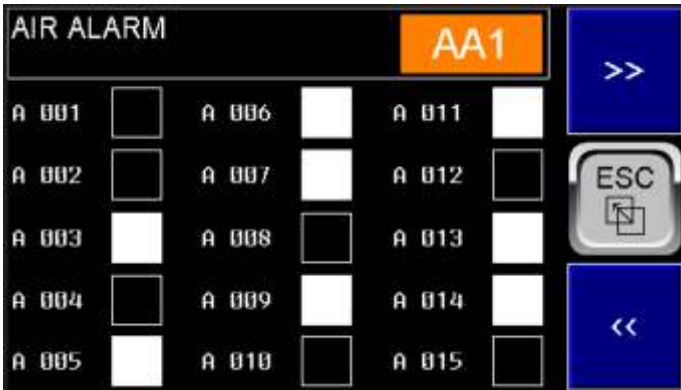

AIR ALARM AA1 to AA9:

There are 7 screens scrolled by the >> and << keys.
 Aa1 to AA7: Screen Index. Flashes if any of the Air (Body) values is above the value programmed for the alarm.
 A001 to A100 (from screens AA1 to AA7): Indicates whether the temperature of each Air (Body) is above the value programmed for the alarm.

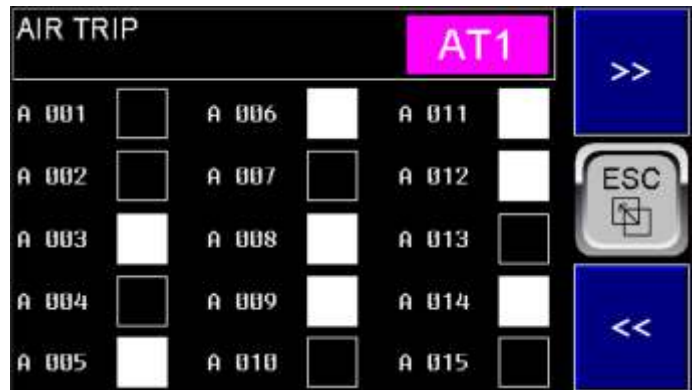

AIR TRIP AT1 to AT7:

There are 7 screens scrolled by the >> and << keys.
 AT1 to AT7: Screen Index. Flashes if any of the Air (Body) values is above the value programmed for Trip.
 A001 to A100 (from screens AT1 to AT7): Indicates whether the temperature of each Air (Body) is above the value programmed for Trip.

MAIN SCREENS FOR OPERATION

6a- TRENDS (THM)

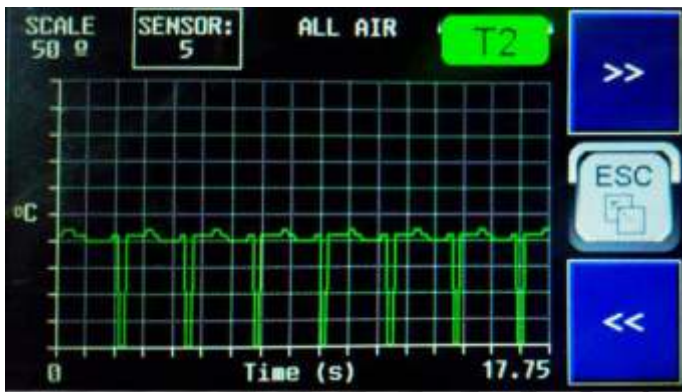
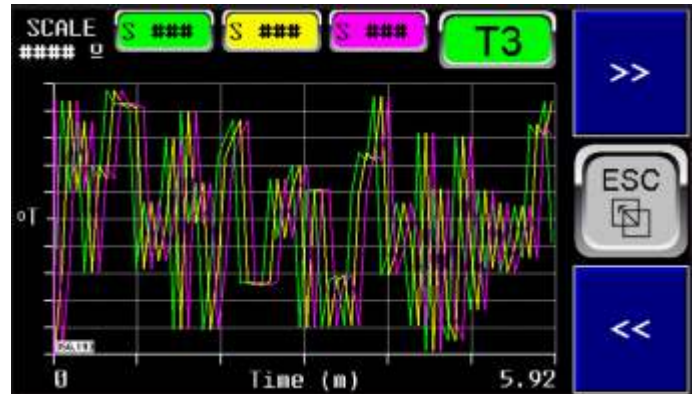
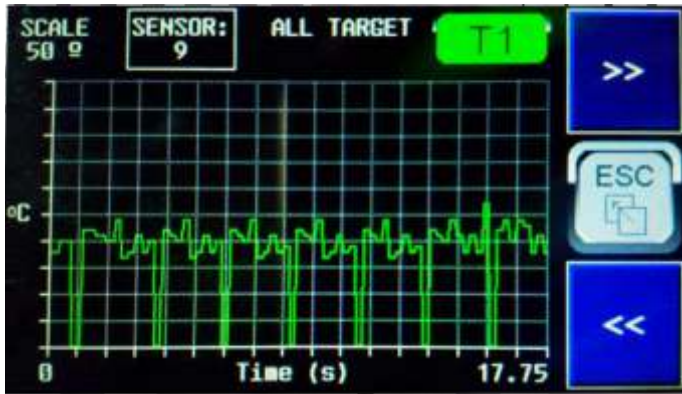

TRENDING PLOT T1 and T2 (Continuous Scope):

There are 18 screens, scrolled by the >> and << keys. These are the first two.
T1 and T2: Screen Index and curve reset button (Plot restart) if programmed to be active in the programming menu.
The first two show all the Target and Air temperatures respectively, of the sensors programmed in the network. With each 'scan' of all the temperatures, the curve goes down to zero and repeats this continuously as if it were an electrocardiogram. The 'scan' never stops and the curve is continuously shifted to the left.
The sampling time is 50 ms and each screen can show 17.75 seconds. When leaving this screen and returning to it, the curves restart, unlike the curves from T4 to T18.

TRENDINGPLOT T3 (Continuous Scope):

This is the third screen of the 18 plot screens, scrolled by the >> and << keys.
T3: Screen Index and curve reset button (Plot restart) if programmed to be active in the programming menu.
On this screen, you can enter the indexes of 3 sensors, from 1 to 100, and if you enter «0» (Zero), the trace remains at zero. With each 'scan', the curve goes down to zero and repeats this continuously as if it were an electrocardiogram. The «scan» never stops and the curve is continually shifted to the left.
The sampling time is 1000 ms, and each screen can show 5.92 minutes in total. When you leave this screen and return to it, the curves restart, unlike the curves from T4 to T18.
When you press the T3 key, the button appears in red, asking if you are sure you want to restart the curves on this screen. If yes, the operator will have 10 seconds to enter the answer "Yes" on the button and touch T3 again. Otherwise, the red button disappears and the curves are not reset.

MAIN SCREENS FOR OPERATION

18- ARC STATUS / TIMESTAMP

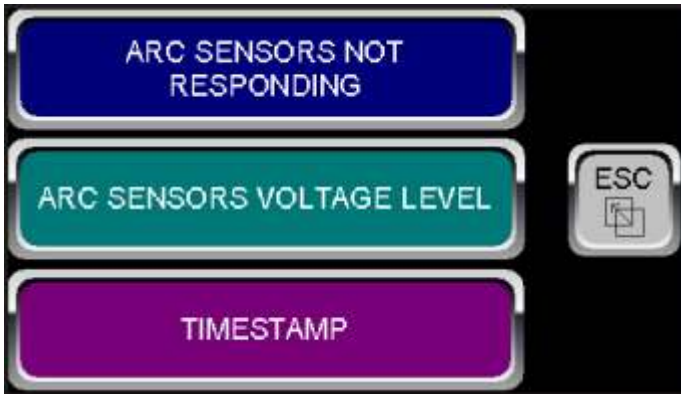

Mono Gateway Version «Arc Status» Screen

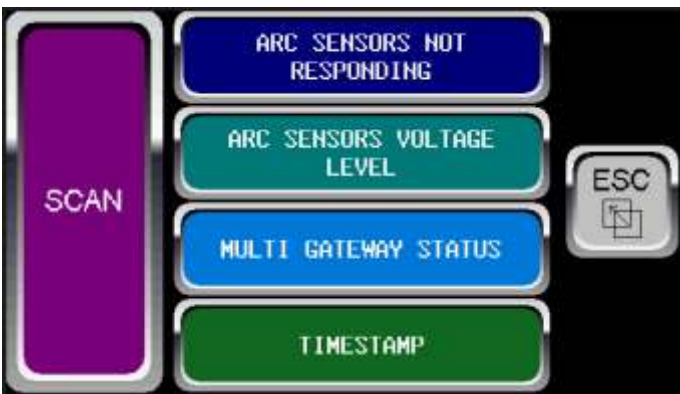

Multi Gateway Version «Arc Status» Screen



NOT RESPONDING NRA1 to NRA7: Accessed by pressing <ARC SENSOR NOT RESPONDING>

There are 7 screens, scrolled by the >> and << keys. S001 to S100 (screens NRA1 to NRA7): Indicates whether the respective arc sensor has stopped responding to the gateway in the network. Note that the valid indication for each gateway is indicated by the change of the word «WAIT» to «VALID» depending on the number of sensors in the THM and ARC networks. The same observations as above apply to the «Up» and «Down» keys to select the gateway in manual scanning mode. Sensors that are responding correctly are indicated in Green and if a sensor does not respond, its indication will be in Red on the network. The «Gateway» field indicates the Gateway currently being scanned, in the Multi Gateway version. With each Scan, the screen will be refreshed with the current conditions of each Gateway if the scanning mode is in «AUTO» or will remain static on the Gateway selected on the screen if it is in «MANUAL» mode.



ARC SENSORS VOLTAGE LEVEL AV01 to Av04:

There are 4 screens that are scrolled by the >> and << keys. V001 to V100 (screens TV01 to Tv04): Shows the supply voltage reaching each ARC sensor via the communication network. Note that there are 3 factory-set voltage levels, which are shown in 3 different colors: Green if it is within the optimal range (Nominal is 24 VDC, but much lower voltages are allowed), Yellow if it is within an acceptable range in which stable operation is safe, or Red if the voltage is below a safe level for operation but still operating, otherwise the sensor would be in the "Not responding" condition. Note that since the communication network can have different lengths, depending on the cabling used by each user, the sensors that are further away from the V5CON device (Interface) and therefore from the power supply may have a greater voltage drop in the wiring. In this case, the user simply needs to divide the network into more than one branch, since this is possible because the sensors are in parallel and as many branches as necessary can be used for better distribution in the cubicles of each MCC or Switchgear, using the accessory device code ZTA. It is also possible to supply power from both ends of the network. See wiring suggestions in the chapter "Typical Interconnections" earlier in this manual.

This way, the user can be sure that the network is operating under safe conditions.

A fourth color, Violet, shows that the sensor is not responding and the voltage indicated in the sensor voltage field will be 0.00.

The same previous observations apply regarding the scanning mode and the "Up" and "Down" keys.



GATEWAY STATUS GF1 to GF7:

Accessed by pressing <MULTI GATEWAY STATUS>

There are 7 screens, scrolled by the >> and << keys. G1 to G100: Indicates whether the respective gateway has detected any fault. Note that regardless of the indication on this screen, the Gateway has already activated the corresponding alarm or trip output, according to its programming. In the case of arc tripping, the trip output is activated in less than 300 µs. If the "Scan Mode" parameter has been selected as "On Fail Do Scan", then the scanning of the gateways continues even if a fault has been detected by one of them. In this case, the operator must check on the screens above which gateways are in a fault detected condition and manually select the Gateway to be scanned again and check the faults detected, before activating the Reset and erasing the faults stored by the gateway and relay.

PROGRAMING

21- MENU

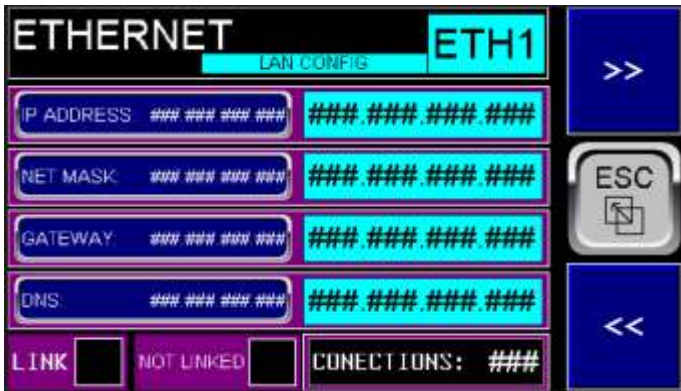

M14A- ETHERNET - LAN CONFIG

M14A.1- IP ADDRESS: Enter the address of the Zy6got V5FTA relay on the LAN network.
M14A.2- NET Mask: Enter the number corresponding to the network mask. Normally 255.255.255.0
M14A.3- Gateway: Enter the number corresponding to the Gateway if necessary. If not necessary, leave it at 0.0.0.0
M14A.4- DNS: Enter the address of the Domain Name Server if necessary. If not used, leave it at 0.0.0.0
 This screen also shows whether the Ethernet cable is connected or not and the number of connections. Note: the number of connections may eventually show «zero» even though it is connected if the transmissions are not repetitive and because it is very fast, there is not enough time to show it on the screen.



M14C- ETHERNET - ICMP (PING)

This screen, like the corresponding screen in the Report Menu, allows you to test whether a specific device on the network is responding, i.e., is active on the network.
M14C.1- PING ADDRESS: Enter the address to perform the ping.
M14C.2- PING RESPOND TIME: Shows the time in milliseconds that the device took to respond.
M14C.3- Tx and Rx: Shows whether it is transmitting or receiving data.
M14C.4- PING TIMEOUT: If the device does not respond in less than 1 second, it will indicate Timeout, i.e., it is not responding.
M14C.5- STAR and STOP: Starts and stops the PING. When exiting the screen, a Stop is automatically given.

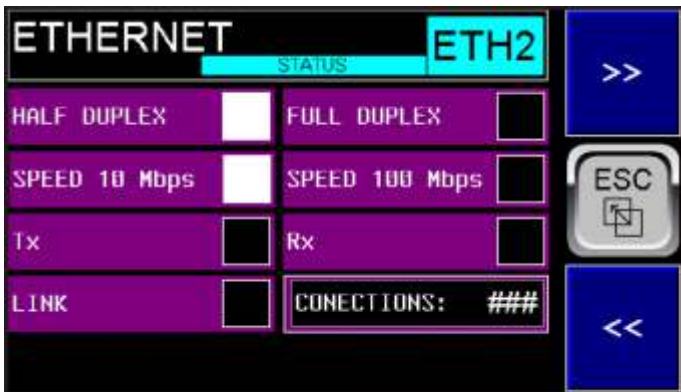

M14B- ETHERNET - STATUS

This screen only shows the various connection statuses, and does not have any fields to be entered.
 The statuses shown are:
M14B.1- HALF DUPLEX or FULL DUPLEX: Shows the connection mode.
M14B.2- SPEED 10 Mbps or 100 Mbps: Shows the connection speed.
M14B.3- Tx and Rx: Shows whether data is being transmitted or received.

M14B.4- LINK: Whether the Ethernet cable is connected (Link) or not and the number of connections. Note: the number of connections may eventually show "zero" but it is connected if the transmissions are not repetitive and because they are very fast there is not enough time to show it on the screen.



M14D- ETHERNET - TCP/IP PROTOCOL - MODBUS SLAVE

This screen refers to the main protocol of the Zyggot V5FTA relay, which allows full Modbus operation, with all functionalities and valid addresses, as well as offsets, etc.

The **SUPERGER** program provided free of charge by Varixx allows, among other features, complete testing of the Modbus Over Ethernet connection with a computer connected to the Zyggot V5FTA relay.

COMPUTER PARAMETERIZATION

ZYGOT SUPERGER

Zygot SuperGer is a configuration software for the Zygot family. The software is available free of charge on the Varixx website (<http://www.varixx.com.br>). The main screen of the program is shown on the side.

It is possible to configure the relay directly on the relay itself and also to perform the complete programming on a relay and to clone this relay to several others using a memory card or pen-drive, as explained previously. install the Superger Software on the Windows computer. All the files necessary to run it, including the «Runtime» files, are already included in the package, so no additional software is required. Once installed, it will be ready to run.



Note: With Zygot Superger you can easily clone the parameters of one relay to another (this can also be done via the uSD card in the case of the V5FTA model relay). To program a series of relays with the same parameters, simply save them (using the «Save» button in the Superger Software) and load the file later if necessary so that all the parameters are ready to «Send» to the relay.

1- The first step is to connect the relay. To do so, adjust the Modbus communication values on the relay and activate it in RS-232 mode. For details on how to activate Modbus, see the programming menu section. Use an RS-232 / RJ45 cable to connect the relay to a computer. You can also use the Ethernet port and do all the programming via Ethernet communication. In this case, program the correct address as programmed on the relay in the Ethernet programming section (Modbus TCP/IP).



2- The next step in the software is to choose the language and working mode on the system configuration screen:

Once you have chosen the language, choose the Zygot V5FTA system relay. Once you have chosen the language and the type of relay, by clicking on its image, select the correct parameters for your computer (COM port 1, COM2, etc.) and the parameters that were programmed on the screen regarding Modbus in the relay (For example: Address: 1, Baudrate: 19200, Timeout: 1000 mS, Parity: None or in the case of Ethernet communication the IP Address, for example: 192.168.1.1

Make sure that Modbus is in the «Active» condition in the relay. Normally, once any parameters related to Modbus in the relay have been changed, it is necessary to turn the relay off and on again for the changes to take effect, as these are parameters related to the relay BIOS.

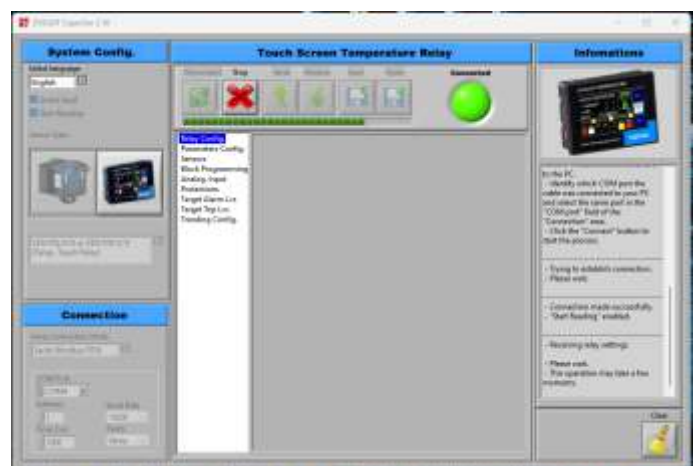

ARC GATEWAY MODBUS SPEC

GENERAL SPECIFICATIONS

Input Register (Modbus function 04) (read-only)

OFFSET	WORD = 16 BIT										0 a 100 sensores							
	32768	16384	8192	4096	2048	1024	512	256	128									
1	16	15	14	13	12	11	10	9	8									
1	Version (value 100 = 1.00)																	
2	Serial Number 32bits - LSB																	
3	Serial Number 32bits - MSB																	
4	Manufacture Day																	
5	Manufacture Month																	
6	Manufacture Year																	
7	Manufacture Lot																	
8	Manufacture User 1																	
9	Manufacture User 2																	
10	Manufacture User 3																	
11	Manufacture User 4																	
12	Sensor Number (Last Sensor Of Network)																	
13	Trip List Size																	
100	OUT TRIP	OUT 2	OUT 1	IN 2	IN 1	Any Sensor Not Responmding	Any Sensor Configured	Any Sensor Trip	CHAIN 0= None , 1= Chain)	Trip Sequence Size (0=none)								
101	OUT TRIP	OUT 2	OUT 1	IN 2	IN 1	Sensor 1 Not Responding	Sensor 1 Configured	Sensor 1 Trip		Sensor 1 Trip Sequence (0=No 1=First N=Position)								
102	TRIP	OUT 2	OUT 1	IN 2	IN 1	Sensor 2 Not Responding	Sensor 2 Configured	Sensor 2 Trip		Sensor 2 Trip Sequence (0=No 1=First N=Position)								
199	TRIP	OUT 2	OUT 1	IN 2	IN 1	Sensor 99 Not Responding	Sensor 99 Configured	Sensor 99 Trip		Sensor 99 Trip Sequence (0=No 1=First N=Position)								
200	TRIP	OUT 2	OUT 1	IN 2	IN 1	Sensor 100 Not Responding	Sensor 100 Configured	Sensor 100 Trip		Sensor 100 Trip Sequence (0=No 1=First N=Position)								
201	Trip List 1 (0=None N=Sensor)																	
202	Trip List 2 (0=None N=Sensor)																	
299	Trip List 99 (0=None N=Sensor)																	
300	Trip List 100 (0=None N=Sensor)																	
301	Sensor 1 Version (100=1.00)																	
302	Sensor 2 Version (100=1.00)																	
399	Sensor 99 Version (100=1.00)																	
400	Sensor 100 Version (100=1.00)																	
401	Sensor 1 Level																	
402	Sensor 2 Level																	
499	Sensor 99 Level																	
1010	0																	
1011	Event 1 - Sequence ID																	
1012	Event 1 - Sensor Number																	
1013	Event 1 - Timestamp Day																	
1014	Event 1 - Timestamp Month																	
1015	Event 1 - Timestamp Year																	
1016	Event 1 - Timestamp Hour																	
1017	Event 1 - Timestamp Minute																	
1018	Event 1 - Timestamp Seconds																	
1019	Event 1 - Repeat Count																	
1500	0																	
1501	Event 50 - Sequence ID																	
1502	Event 50 - Sensor Number																	
1503	Event 50 - Timestamp Day																	
1504	Event 50 - Timestamp Month																	
1505	Event 50 - Timestamp Year																	
1506	Event 50 - Timestamp Hour																	
1507	Event 50 - Timestamp Minute																	
1508	Event 50 - Timestamp Seconds																	
1509	Event 50 - Repeat Count																	

ARC GATEWAY MODBUS SPEC

GENERAL SPECIFICATIONS



OFFSET	WORD = 16 BIT												Default Hex				
	16	15	14	13	12	11	10	9	8	7	6	5		4	3	2	1
1	Trip Mode	OUT_2 Mode B2	OUT_2 Mode B1	OUT_1 Mode B2	OUT_1 Mode B1	IN_2 Mode B2	IN_2 Mode B1	IN_1 Mode	Sensor Network Size (0...100) (Last Sensor Of Network)								0x0000
	0 → Keep On	B2=0 B1=0 → Trip	B2=0 B1=0 → Trip	B2=0 B1=0 → Trip	B2=0 B1=0 → None	B2=0 B1=0 → None	B2=0 B1=0 → None	0 → None	BIT 1 - 8 = 0 a 100 sensores								
	1 → Pulse 3 Sec	B2=0 B1=1 → Armed (No Trip)	B2=0 B1=1 → Armed (No Trip)	B2=0 B1=1 → Armed (No Trip)	B2=0 B1=1 → Reset	B2=0 B1=1 → Reset	B2=0 B1=1 → Reset	1 → Reset									
		B2=1 B1=0 → Alarm	B2=1 B1=0 → Alarm	B2=1 B1=0 → Alarm	B2=1 B1=0 → Inhibits/Disable Trip	B2=1 B1=0 → Inhibits/Disable Trip	B2=1 B1=0 → Inhibits/Disable Trip										
2	x	x	x	x	x	x	x	Blink Active	Sensor to Blink (0=All)								0x0000
								0=no / 1=Blink	BIT 1 - 8 = 0 a 100 sensores								
3	Unlock Bits 12 to 15	Force Out/Trip SCR	Force Out/Trip Relay	Force OUT 2	Force OUT 1	Remote 2	Remote 1	x	x	x	x	x	x	x	x	x	Reset Trip
	0=no / 1=Unlock	0=no / 1=force	0=no / 1=force	0=no / 1=force	0=no / 1=force	0=Off / 1=On	0=Off / 1=On	0=Off / 1=On									0=no / 1=Reset
4	Unlock	Terminator RS485	Baudrate Mode B3	Baudrate Mode B2	Baudrate Mode B1	Parity Mode B2	Parity Mode B1	Stop Bit Mode	RS485 Gateway Modbus Address - SLAVE ID (Initial = 200)								0x20C8
	0 → Read-only	0 → No Resistor	B3=0 B2=0 B1=0 → 1200	B3=0 B2=0 B1=0 → 1200	B3=0 B2=0 B1=0 → None	B2=0 B1=0 → None	0 → 1 stop bits										
	1 → Enable Bits 1 to 14	1 → 120R Resistor	B3=0 B2=0 B1=1 → 2400	B3=0 B2=0 B1=1 → 2400	B2=0 B1=1 → Even	B2=0 B1=1 → Even	1 → 2 stop bits										
			B3=0 B2=1 B1=0 → 4800	B3=0 B2=1 B1=0 → 4800	B2=1 B1=0 → Odd	B2=1 B1=0 → Odd											
			B3=0 B2=1 B1=1 → 9600	B3=0 B2=1 B1=1 → 9600													
			B3=1 B2=0 B1=0 → 19200	B3=1 B2=0 B1=0 → 19200													
		B3=1 B2=0 B1=1 → 38400	B3=1 B2=0 B1=1 → 38400														
		B3=1 B2=1 B1=0 → 57600	B3=1 B2=1 B1=0 → 57600														
		B3=1 B2=1 B1=1 → 115200	B3=1 B2=1 B1=1 → 115200														
5	Clock Control (0=KEEP, 1=READ, 2=WRITE)																
6	Clock Day (1...31)																
7	Clock Month (1..12)																
8	Clock Year (1..3000)																
9	Clock Hour (0..24)																
10	Clock Minute (0..60)																
11	Clock Second (0..60)																
12	Manufacture Write Unlock Password (Enable change registers 21 to 30)																
13	Serial Number 32bits - LSB																
14	Serial Number 32bits - MSB																
15	Manufacture Day																
16	Manufacture Month																
17	Manufacture Year																
18	Manufacture Lot																
19	Manufacture User 1																
20	Manufacture User 2																
21	Manufacture User 3																
22	Manufacture User 4																
23	Clear All Saved Event																

MODBUS OVER ETHERNET TCP IP SERVER



GENERAL SPECIFICATIONS (PART 1 / 4)

MODBUS OVER ETHERNET ETHERNET IP SERVER - COMMUNICATION WILL WORK WITH PLCs AND ALLEN BRADLEY PROTOCOL OR ALLEN BRADLEY LIKE
 Maximum connection = 2 // PORT = 44818 TCP or 2222 UDP.
 SEND (PRODUCED) FIRST REGISTER = %R2801 /// LAST REGISTER = %R2928 /// WORDS COUNT = 128.
 RECEIVE (CONSUMED) FIRST REGISTER = %R3201 /// LAST REGISTER = %R3328 /// WORDS COUNT = 128.
 The Status word provides Ethernet/IP connection status. The upper byte of the word contains the Class 3 (Explicit) connection count and the lower byte contains the Class 1 (IO) connection count.

NOTE: When the Status word indicates no connections, the Consumed OCS registers contain old data.
 As up to 128 words are allowed in each communication, a pagination scheme is used to access all important and available data.
 In this version, parameter programming via the Ethernet connection is not allowed, so the variable on the corresponding screen is permanently set to "Disabled".
 However, it is allowed to send some commands via the Ethernet connection, in addition to specifying the page to be read.

CONSUMED	Controller Tags	WRITE PAGE 1 TO 16	FUNCTION RESERVED FOR FUTURE USE	MULTIPLE GATEWAY VERSION		NOTE	WARNING
				DATA			
%R3201 - %3300							
%R3301	O.Data[100]	0	MUTE	1= MUTE // 0 = DO NOTHING		SEND COMMAND MUTE TO RELAY	
%R3302	O.Data[101]	0	RESET	1= RESET // 0 = DO NOTHING		SEND COMMAND RESET TO RELAY	
%R3303	O.Data[102]	0	SAVE TARGET	1= SAVE // 0 = DO NOTHING		SAVE TARGET DATA TO MEMORY CARD	
%R3304	O.Data[103]	0	SAVE AIR	1= SAVE // 0 = DO NOTHING		SAVE AIR DATA TO MEMORY CARD	
%R3305	O.Data[104]	0	GATEWAY SCAN AUTO	1= CHANGE TO SCAN AUTO // 0 = DO NOTHING		TRANSITION SENSITIVE - CHANGE FROM MAN TO AUTO	
%R3306	O.Data[105]	0	GATEWAY SCAN MANUAL	1= CHANGE TO SCAN MANUAL // 0 = DO NOTHING		TRANSITION SENSITIVE - CHANGE FROM AUTO TO MAN	
%R3307	O.Data[106]	0	SCAN GATEWAY NUMBER	SET 1 TO 40		CHANGE TO MANUAL FIRST TO READ THE SETTLED GATEWAY	
%R3308	O.Data[107]	0	TIME STAMP EVENT	SET 1 TO 50		CHANGE TO MANUAL FIRST TO READ THE SETTLED GATEWAY	
%R3309	O.Data[108]	0	RESET DIFFERENTIAL WARM	1= RESET DIFFERENTIAL // 0 = DO NOTHING		RESET DIFFERENTIAL WITH A NEW WARM PERIOD	CAUTION
%R3310	O.Data[109]	0	RESET DIFFERENTIAL NO WARM	1= RESET DIFFERENTIAL // 0 = DO NOTHING		RESET DIFFERENTIAL WITHOUT A NEW WARM PERIOD	CAUTION
%R3311	O.Data[110]	0	FORCE GATEWAY OUTPUT 1	1= FORCE // 0 = DO NOTHING		CHANGE TO MANUAL FIRST AND SET THE GATEWAY TO BE FORCED	AVOID IF POSSIBLE
%R3312	O.Data[111]	0	FORCE GATEWAY OUTPUT 2	1= FORCE // 0 = DO NOTHING		CHANGE TO MANUAL FIRST AND SET THE GATEWAY TO BE FORCED	AVOID IF POSSIBLE
%R3313	O.Data[112]	0	FORCE GATEWAY TRIP RELAY	1= FORCE // 0 = DO NOTHING		CHANGE TO MANUAL FIRST AND SET THE GATEWAY TO BE FORCED	AVOID IF POSSIBLE
%R3314	O.Data[113]	0	FORCE GATEWAY TRIP THYRISTOR	1= FORCE // 0 = DO NOTHING		CHANGE TO MANUAL FIRST AND SET THE GATEWAY TO BE FORCED	AVOID IF POSSIBLE
%R3315		0	RESERVED				
%R3316		0	RESERVED				
%R3317		0	RESERVED				
%R3318		0	RESERVED				
%R3319		0	RESERVED				
%R3320		0	RESERVED				
%R3321		0	RESERVED				
%R3322		0	RESERVED				
%R3323		0	RESERVED				
%R3324		0	RESERVED				
%R3325		0	RESERVED				
%R3326	O.Data[114]	0	PAGE TO WRITE	NOTE USED IS THIS VERSION			
%R3327	O.Data[115]	0	PAGE TO READ	SET PAGE FROM 0 TO 15 TO BE READ FROM RELAY		0 = DO NOTHING // 1 TO 15 SET PAGE TO BE READ	
%R3328	O.Data[116]	0	WRITING DATA VALID	1= DATA TO BE WRITE = VALID // 0 = DO NOTHING		NOTE USED IN THIS VERSION	

MODBUS OVER ETHERNET TCP IP SERVER



GENERAL SPECIFICATIONS (PART 2 / 4)

PRODUCED	READ PAGE	FUNCTION	DATA	NOTE	WARNING
%R2927	0 - 16	PAGE READED	0 - 16		
%R2928	0 - 16	DATA READED VALID	1 = DATA VALID // 0 = WAIT NEW DATA	0 = READED NONE // CORRESPONDENT 1 TO 15 DATA WILL BE READED	
%R2801 - %R2900	1 TO 16	DATA PAGES	SEE BELOW	CONSIDER THE DATA READED ONLY IF %R2928 = 1	
%R2801 - %R2900	1	TARGET TEMPERATURES 1 TO 100	x 10 - AS READED (FORMAT XXX.X)	THE DATA NEED TO BE DIVIDED BY 10 TO INSERT THE COMA	
%R2801 - %R2900	2	AIR TEMPERATURES 1 TO 100	x 10 - AS READED (FORMAT XXX.X)	THE DATA NEED TO BE DIVIDED BY 10 TO INSERT THE COMA	
%R2801 - %R2900	3	TARGET ALARM LEVELS 1 TO 100	x 10 - AS READED (FORMAT XXX.X)	THE DATA NEED TO BE DIVIDED BY 10 TO INSERT THE COMA	
%R2801 - %R2900	4	TARGET TRIP LEVELS 1 TO 10	x 10 - AS READED (FORMAT XXX.X)	THE DATA NEED TO BE DIVIDED BY 10 TO INSERT THE COMA	
%R2901	3	AIR ALARM LEVELS TO ALL SENSORS	x 10 - AS READED (FORMAT XXX.X)	THE DATA NEED TO BE DIVIDED BY 10 TO INSERT THE COMA	
%R2901	4	AIR TRIP LEVELS TO ALL SENSORS	x 10 - AS READED (FORMAT XXX.X)	THE DATA NEED TO BE DIVIDED BY 10 TO INSERT THE COMA	
%R2801 - %R2900	5	THM SENSORS VOLTAGE	X100 - AS READED (FORMAT XX.XX)	THE DATA NEED TO BE DIVIDED BY 100 TO INSERT THE COMA	
%R2801 - %R2900	6	ARC SENSORS VOLTAGE	X100 - AS READED (FORMAT XX.XX)	CHANGE TO MANUAL AND SET THE GATEWAY FIRST AT %R3307	
%R2801 - %R2900	7	TARGET ALARM ACTIVE 1 TO 100	2 = ACTIVE // 0 = INACTIVE		
%R2801 - %R2900	8	TARGET TRIP ACTIVE 1 TO 100	2 = ACTIVE // 0 = INACTIVE		
%R2801 - %R2900	9	AIR ALARM ACTIVE 1 TO 100	2 = ACTIVE // 0 = INACTIVE		
%R2801 - %R2900	10	AIR TRIP ACTIVE 1 TO 100	2 = ACTIVE // 0 = INACTIVE		
%R2801 - %R2900	11	THM SENSORS STATUS	0 = RESPONDING // 1 = NOT RESPONDING		
%R2801 - %R2900	12	ARC SENSORS STATUS	0 = RESPONDING // 1 = NOT RESPONDING	CHANGE TO MANUAL AND SET THE GATEWAY FIRST	
%R2801 - %R2900	13	GATEWAYS STATUS	0 = RESPONDING // 1 = NOT RESPONDING	SEE ALL GATEWAYS RESPONDING OR NOT (1 TO 40)	
%R2801 - %R2900	14	ARC SEQUENCE	AS READED - SAME AS THE DISPLAY	CHANGE TO MANUAL AND SET THE GATEWAY FIRST AT %R3307	
%R2801	15	THM COMM OK	0 = NOT OK // 1 = OK		
%R2802	15	THM COMM NOT OK	0 = OK // 1 = NOT OK		
%R2803	15	ARC COMM OK	0 = NOT OK // 1 = OK		
%R2804	15	ARC COMM NOT OK	0 = OK // 1 = NOT OK		
%R2805	15	GATEWAY PGMD	0 = NO // 1 = PROGRAMMED		
%R2806	15	GATEWAY READY	0 = NO // 1 = READY	CHANGE TO MANUAL AND SET THE GATEWAY FIRST AT %R3307	
%R2807	15	GATEWAY ALRME	0 = NO // 1 = ALARMED	CHANGE TO MANUAL AND SET THE GATEWAY FIRST AT %R3307	
%R2808	15	GATEWAY TRIP	0 = NO // 1 = TRIPPED	CHANGE TO MANUAL AND SET THE GATEWAY FIRST AT %R3307	
%R2809	15	GATEWAY CHAIN INPUT	0 = NO // 1 = CHAIN ACTIVE	CHANGE TO MANUAL AND SET THE GATEWAY FIRST AT %R3307	
%R2810	15	INHIBITED	0 = NO // 1 = INHIBITED		
%R2811	15	LINK STATE	0 = ETHERNET NOT LINKED // 1 = LINKED		
%R2812	15	RESERVED			
%R2813	15	ANY FAIL ACTIVE	0 = NO // FAIL ACTIVE		
%R2814	15	TARGET FAIL	0 = NO // FAIL ACTIVE		
%R2815	15	AIR FAIL	0 = NO // FAIL ACTIVE		
%R2816	15	ALARM ACTIVE	0 = NO // ALARM ACTIVE		
%R2817	15	TRIP ACTIVE	0 = NO // TRIP ACTIVE		
%R2818	15	ALARM UNACKNOWLEDGED	0 = NO // 1 = YES		
%R2819	15	ALARM UNCLEARD	0 = NO // 1 = YES		
%R2820	15	TARGET ALARM ACTIVE	0 = NO // 1 = YES		
%R2821	15	TARGET TRIP ACTIVE	0 = NO // 1 = YES		
%R2822	15	AIR ALARM ACTIVE	0 = NO // 1 = YES		
%R2823	15	AIR TRIP ACTIVE	0 = NO // 1 = YES		

MODBUS OVER ETHERNET TCP IP SERVER

GENERAL SPECIFICATIONS (PART 3 / 4)

PRODUCED	READ PAGE	FUNCTION	DATA	NOTE	WARNING
%R2824	15	THM SENSOR FAIL ACTIVE	0 = NO // 1 = YES		
%R2825	15	EXTERNAL FAIL 1 ACTIVE	0 = NO // 1 = YES		
%R2826	15	EXTERNAL FAIL 2 ACTIVE	0 = NO // 1 = YES		
%R2827	15	ANALOG 1 ALARM ACTIVE	0 = NO // 1 = YES		
%R2828	15	ANALOG 2 ALARM ACTIVE	0 = NO // 1 = YES		
%R2829	15	ANALOG 3 ALARM ACTIVE	0 = NO // 1 = YES		
%R2830	15	ANALOG 4 ALARM ACTIVE	0 = NO // 1 = YES		
%R2831	15	ANALOG 1 TRIP ACTIVE	0 = NO // 1 = YES		
%R2832	15	ANALOG 2 TRIP ACTIVE	0 = NO // 1 = YES		
%R2833	15	ANALOG 3 TRIP ACTIVE	0 = NO // 1 = YES		
%R2834	15	ANALOG 4 TRIP ACTIVE	0 = NO // 1 = YES		
%R2835	15	EXCESS LIFE ACTIVE	0 = NO // 1 = YES		
%R2836	15	DIFFERENTIAL ALARM ACTIVE	0 = NO // 1 = YES		
%R2837	15	DIFFERENTIAL TRIP ACTIVE	0 = NO // 1 = YES		
%R2838	15	REMOTE 1 ACTIVE	0 = NO // 1 = YES		
%R2839	15	REMOTE 2 ACTIVE	0 = NO // 1 = YES		
%R2840	15	G1 TARGT ALARM ACTIVE	0 = NO // 1 = YES		
%R2841	15	G2 TARGT ALARM ACTIVE	0 = NO // 1 = YES		
%R2842	15	G3 TARGT ALARM ACTIVE	0 = NO // 1 = YES		
%R2843	15	G4 TARGT ALARM ACTIVE	0 = NO // 1 = YES		
%R2844	15	G5 TARGT ALARM ACTIVE	0 = NO // 1 = YES		
%R2845	15	G1 AIR ALARM ACTIVE	0 = NO // 1 = YES		
%R2846	15	G2 AIR ALARM ACTIVE	0 = NO // 1 = YES		
%R2847	15	G3 AIR ALARM ACTIVE	0 = NO // 1 = YES		
%R2848	15	G4 AIR ALARM ACTIVE	0 = NO // 1 = YES		
%R2849	15	G5 AIR ALARM ACTIVE	0 = NO // 1 = YES		
%R2850	15	G1 TARGT TRIP ACTIVE	0 = NO // 1 = YES		
%R2851	15	G2 TARGT TRIP ACTIVE	0 = NO // 1 = YES		
%R2852	15	G3 TARGT TRIP ACTIVE	0 = NO // 1 = YES		
%R2853	15	G4 TARGT TRIP ACTIVE	0 = NO // 1 = YES		
%R2854	15	G5 TARGT TRIP ACTIVE	0 = NO // 1 = YES		
%R2855	15	G1 AIR TRIP ACTIVE	0 = NO // 1 = YES		
%R2856	15	G2 AIR TRIP ACTIVE	0 = NO // 1 = YES		
%R2857	15	G3 AIR TRIP ACTIVE	0 = NO // 1 = YES		
%R2858	15	G4 AIR TRIP ACTIVE	0 = NO // 1 = YES		
%R2859	15	G5 AIR TRIP ACTIVE	0 = NO // 1 = YES		
%R2860	15	GATEWAY NOT PROGRAMMED	0 = NO // 1 = YES		
%R2861	15	ANY ARC GATEWAY COMM FAIL	0 = NO // 1 = YES		
%R2862	15	ARC SENSOR NOT RESPONDIG FAIL	0 = NO // 1 = YES		
%R2863	15	ARC FLASH ALARM ACTIVE	0 = NO // 1 = YES		
%R2864	15	ARC FLASH TRIP ACTIVE	0 = NO // 1 = YES		
%R2865	15	ARC CHAIM ACTIVE (TRIP)	0 = NO // 1 = YES		

MODBUS OVER ETHERNET TCP IP SERVER

GENERAL SPECIFICATIONS (PART 4 / 4)

PRODUCED	READ PAGE	FUNCTION	DATA	NOTE	WARNING
%R2866	15	SCREEN ALARM UNCLEARED	0 = NO // 1 = YES		
%R2867	15	SCREEN ALARM UNACKNOWLEDGED	0 = NO // 1 = YES		
%R2868	15	SCREEN ALARM ANY FAIL ACTIVE	0 = NO // 1 = YES		
%R2869	15	SCANNING GATEWAY AUTO	0 = NO // 1 = YES		
%R2870	15	SCANNING GATEWAY MANUAL	0 = NO // 1 = YES		
%R2801	16	MAX TARGET TEMPERATURE	x 10 - AS READED (FORMAT XXX.X)	THE DATA NEED TO BE DIVIDED BY 10 TO INSERT THE COMA	
%R2802	16	MAX AIR TEMPERATURE	x 10 - AS READED (FORMAT XXX.X)	THE DATA NEED TO BE DIVIDED BY 10 TO INSERT THE COMA	
%R2803	16	MEMORY CARD STATUS	0=OK// 1= UNKNOWN FORMAT// 2=NO CARD//	3= NOT SUPPORTED//4=ILEGAL SWAP//5=UNKNOWN//PROTECTED	
%R2804	16	DIFFERENTIAL TIME TO WARM HOUR	AS READED		
%R2805	16	DIFFERENTIAL TIME TO WARM MINUTE	AS READED		
%R2806	16	DIFFERENTIAL TIME TO RESTART HOUR	AS READED		
%R2807	16	DIFFERENTIAL TIME TO RSTRT MINUTE	AS READED		
%R2808	16	DIFFERENTIAL ON	0 = NO // 1 = YES		
%R2809	16	DIFFERENTIAL WARM OK	0 = NO // 1 = YES		
%R2810	16	DIFFERENTIAL FIRST READ OK	0 = NO // 1 = YES		
%R2811	16	DIFFERENTIAL VALID (OPERATING)	0 = NO // 1 = YES		
%R2812	16	REDING THM SENSOR NUMBER	AS READED (1 TO 100)		
%R2813	16	SCANNING GATEWAY NUMBER	AS READED (1 TO 40)		
%R2814	16	REDING ARC SENSOR NUMBER	AS READED (1 TO 100)		
%R2815	16	TOTAL THM SENSOR RESPONDING	0 TO 100		
%R2816	16	TOTAL THM SENSOR NOT RESPONDING	0 TO 100		
%R2817	16	TOTAL ALRM ACTIVE			
%R2818	16	TOTAL TRIP ACTIVE			
%R2819	16	TOTAL ARC SENSOR RESPONDING			
%R2820	16	TOTAL ARC SENSOR NOT RESPONDING			
%R2821	16	TOTAL ARC FLASH NOT CLEARED			
%R2822	16	TIME TO RETURN TO SCAN AUTO	AS READED (600 TO 0 s)		
%R2823	16	REAL TIME CLOCK DAY	1 TO 31		
%R2824	16	REAL TIME CLOCK MONTH	1 TO 12		
%R2825	16	REAL TIME CLOCK YEAR			
%R2826	16	REAL TIME CLOCK HOUR	0 TO 24		
%R2827	16	REAL TIME CLOCK MINUTE	0 TO 60		
%R2828	16	REAL TIME CLOCK SECONDS	0 TO 60		
%R2829	16	STOPPED SCANNING ON GATEWAY	1 TO 40		

CHANGE TO MANUAL AND SET THE GATEWAY FIRST AT %R3307

CHANGE TO MANUAL AND SET THE GATEWAY FIRST AT %R3307

CHANGE TO MANUAL AND SET THE GATEWAY FIRST AT %R3308

CHANGE TO MANUAL AND SET THE GATEWAY FIRST AT %R3308

ABOUT VARIXX

For over 40 years, Varixx has pursued its vocation for developing high-tech products and focuses its efforts on serving the industrial market with quality and speed. Our know-how in power electronics has allowed us to offer the market a wide range of products that have become known for their long service life and reliability. We were the creators of the global online thermography market, with the Zyggot line, which is becoming a global reference in the market for temperature monitoring and diagnostics and arc flash detection in electrical systems in general.

Our product portfolio also includes LED luminaires from our ONNO division, developed and manufactured 100% in Brazil with cutting-edge technology. Varixx values the introduction of innovative concepts worldwide.

AREAS OF ACTIVITY

- ✓ **MANUFACTURERS OF GENERATOR MACHINES AND SYNCHRONOUS MOTORS**
Static Exciters, Control Box Controllers, Low and Medium Voltage Soft Starters, Semiconductors
- ✓ **PRODUCTION OF ALUMINUM AND HYDROGEN / OXYGEN**
High Current Rectifiers, Solid State Contactors, Smart Relay for CCM, Online Thermography System and Arc Flash Detection and Onno LED Luminaires.
- ✓ **BASE INDUSTRY, MINING AND STEEL INDUSTRY**
Smart Relays for CCMs, Low and Medium Voltage Soft Starters, Solid State Contactors, AC/DC Converters for electromagnets, High Current Rectifiers, Online Thermography System, Arc Flash Detection and Protection and Onno LED Luminaires.
- ✓ **OIL COMPANIES**
Smart Relays for CCMs, Static Excitation, Low and Medium Voltage Soft Starters, Solid State Contactors, Online Thermography System, Arc Flash Detection and Protection and Onno LED Luminaires.
- ✓ **ELECTRIC PANEL ASSEMBLERS**
Smart Relays for CCMs, Online Thermography, Arc Flash Detection and Protection System, Semiconductors, Power Supplies and Onno LED Luminaires.

Why ZYGGOT Thermography And Arc Flash Protection?



SINGLE CABLE / EASY TO INSTALL



PREDICTIVE / DIFFERENTIAL PROTECTION



EFFECTIVE PROTECTION AGAINST ARC DESTRUCTION



WORLDWIDE UNIQUE BY UV DETECTION / NO CURRENT READINGS REQUIRED



DOES NOT NEED CONVENTIONAL THERMOGRAPHY / ALSO MEASURES AIR TEMP.



WITHOUT CONTACT / WITH NETWORK COMMUNICATION

LEARN MORE!

ZYGGOT ARC FLASH SYSTEM

- ✓ **Low Cost // Up to 100 sensors per gateway.**
- ✓ **Innovative in the market // Faster (<300 uS versus up to 500 mS)**
- ✓ **Ultraviolet arc detection**
- ✓ **Does not operate with ambient light (False Alarm)**
- ✓ **No need for current readings**

varixx

ALWAYS INNOVATING

www.varixx.com.br
vendas@varixx.com.br
+55 (19) 3424-4000
+55 (19) 3301-6900

R. Felipe Zaidan Maluf, 450
Distrito Industrial Unileste
Piracicaba-SP. CEP: 13422-190



@Varixxbrasil



@varixxcompany



Varixx Indústria Eletrônica



www.varixx.com
www.varixx.com.br

Representative/Distributor:

VARIXX USA

2229 Allen Parkway, Suite 200
+1 832-871-5700
Houston - Texas, 77019

VARIXX WORLDWIDE

MORE THAN 20 BRANCHES,
DISTRIBUTORS AND REPRESENTATIVE
OFFICES WORLDWIDE



ZYGGOT THERMOGRAPHY