



# ZYGGOT ARC SPL

LOW COST ULTRAVIOLET ARC FLASH PROTECTION SYSTEM

## ZYGGOT ARC SPL SYSTEM

LOW COST ULTRAVIOLET ARC FLASH PROTECTION SYSTEM

World's First Online Thermography System (2004).  
World Leader in Continuous Temperature Monitoring.  
World's First UV Arc Protection System\*.  
Over 1 Million Sensors Installed Worldwide.  
\* Patent No. PI 0903809-4

MANUAL ZYGGOT ARC SPL V2.1 ENG January 2025

# varixx

# INDEX

DESCRIPTION .....	3
KEY POINTS .....	4
TECHNOLOGY AND TECHNICAL DETAILS .....	5
TECHNOLOGY AND MAIN FEATURES OF THE ARC SYSTEM .....	6
PRINCIPLE OF OPERATION OF THE ARC SYSTEM .....	7
ZAG1R/SPL GATEWAY SIDE OVERLAY AND LABEL .....	8
SYSTEM DETAILS .....	9
BASIC SCHEME WITH 115 VAC / 125 VDC TRIP COIL .....	10
EXAMPLE OF TYPICAL APPLICATION AND BASIC SYSTEM COMPOSITION .....	11
PROGRAMMING SENSORS WITH ZYGGOT SUPERGER SOFTWARE .....	12
USING THE ARC SAFE TESTER .....	13
ACCESSORIES .....	14

The manual is also available in Portuguese on the website [varixx.com](http://varixx.com) and also on the website [varixx.com.br](http://varixx.com.br).

# ZYGGOT ARC SPL

## LOW COST ARC FLASH PROTECTION SYSTEM



Ultraviolet Arc Tubular Sensors with 90° viewing angle

### DESCRIPTION

Varixx was the world's pioneer in introducing a Continuous, Online, Networked Temperature Monitoring System in 2004 and is a market leader in this area.

Later, it introduced the world's first ultraviolet arc detection system with the ZYGGOT ARC family, with a dedicated relay, supporting the connection of up to 50 arc sensors. It recently introduced the first continuous temperature monitoring system integrated with an ultraviolet arc protection system with multiple triggering Gateways providing high selectivity, with the use of one Gateway per circuit breaker to be tripped in the event of an arc, called THM+ARC. The system described in this manual, called ZYGGOT ARC SPL, was derived from this system.

The low-cost ZYGGOT ARC SPL system was designed to provide protection against ARC FLASH, with high selectivity, with the world's best technology for detecting and protecting against electric arcs, using ultraviolet light (Patent PI 0903809-4), which enables a reduction of up to 150 times in incident energy, compared to systems that detect visible light and current.

Sensors with 90° opening angles allow monitoring of an entire cubicle with a single sensor, since their high sensitivity allows detection of the beginning of an electric arc even at points outside their viewing angle or hidden by equipment, thanks to the reflection of UV radiation on the internal walls of the panel.

The Ultraviolet detection mode does not require confirmation of current increase and inhibits the formation of an arc at its beginning due to its extremely fast action (<250 uS), detecting the arc in its initial phase and not in the fourth phase of the arc, unlike existing systems that detect light and current, which only reduce the effect of the arc, already formed, thus reducing the incident energy by around 80 to 150 times compared to the competition. It is a system that has already been widely approved, with hundreds of real cases of detection and actuation, with minimal or no damage to the protected systems, with a return time of minutes to a few hours.

In addition, since it does not require current monitoring, it is very easy to implement and costs much less than light and current detection systems.

The system presented in this manual is in addition to the independent THM and Arc Flash systems, which continue in the product portfolio, with Modbus and Ethernet communication and several additional programming and protection features. The ZYGGOT ARC SPL system provides efficient protection against electric arcs in equipment that does not allow for high implementation costs. Its particularity is that it does not include a dedicated relay, which is expensive, but it still offers the possibility of connecting up to 50 arc sensors.



### APPLICATION

Low-cost Arc Flash Protection.

### BENEFITS

- \* Arc detection in phase 1 (pre-arc).
- \* Reduction of incident energy between 80 and 150 times compared to the competition.
- \* Indicates any faulty sensor.
- \* They can be chained with multiple Gateways by tripping upstream via the «Chain» input.

### System Features

- \* Applicable to low and medium voltage.
- \* Up to 50 UV arc sensors in CAN network with mini USB connections.
- \* Smart Sensors powered by the network itself.
- \* 90° measurement angle for Arc.
- \* External fault monitoring.
- \* Sensor status monitoring.
- \* \* 2 programmable digital outputs per Gateway in addition to the trip output.
- \* Each sensor has a multicolored flashing LED for verification of the communication integrity and fault and alarm indication.
- \* Arc Flash Protection with Gateway independent triggers and up to 50 Arc sensors for Ultraviolet detection per Gateway.
- \* The Gateway has an output for indication by light signal on the panel door.
- \* The Gateway has a trip output via static contact in parallel with dry contact, ensuring fast operation.
- \* Easy installation without the need for tools. CAN connection cables are supplied ready-made in lengths ranging from 30 cm to 8 meters. Simply plug and play.

# KEY POINTS

## Main Advantages

- WORLD'S MOST ADVANCED ARC PROTECTION
- HIGH SELECTIVITY FOR ARC (MULTI GATEWAY)
- ARC ACTUATION IN LESS THAN 250uS
- REDUCES INCIDENT ENERGY BY UP TO 150X
- DISPENSES CURRENT MEASUREMENT FOR ARC
- CAN DETECT UV AT NON-VISIBLE POINTS
- DOES NOT USE BATTERIES
- PROVEN RELIABILITY
- WITHOUT ELECTRICAL CONTACT
- WORLD LEADING SYSTEM

The low-cost ZYGGOT ARC SPL system, with stainless steel tubular sensors, was developed for low and medium voltage panels. The sensors detect UV radiation in the first phase of the arc, without physical contact and allow local and online protection for up to 50 sensors per Gateway. The sensors are connected to a high-speed CAN network, using mini USB cables, in sizes from 0.3 to 8.0 meters (supplied), which allows for fast, error-free installation without tools. The triggering Gateway provides ultra-fast triggering / tripping output. A possible failure in one of the sensors does not interrupt the operation of the other sensors. The sensors are connected to a high-speed CAN network and are immune to intense magnetic fields. This system (including the standard Zyggot ARC) has been operating in thousands of installations without failures for many years, and with hundreds of real cases of 100% effective protection, proving its reliability.

## KEY POINTS

- Arc flash protection by UV, the most advanced in the world (Patent No. PI 0903809-4).
- Reduces incident energy by up to 150x compared to systems by light and current detection.
- Dispenses with current measurement for arc flash confirmation.
- Multi Gateways allow high selectivity for arc tripping, using a low-cost triggering Gateway per cubicle or per associated circuit breaker.
- Each Gateway can receive up to 50 arc sensors.

## APPLICATIONS

- Internamente a painéis para proteção contra arco voltaico.
- Supervisão de subestações.

## MAIN FEATURES

- Up to 50 arc sensors per Gateway.
- Monitors Arc Flash by UV detection.
- Dispenses current measurement for arc confirmation.
- Actuation in less than 250uS, in the pre-arc phase, reduces the incident energy by up to 150x in relation to systems by light and current detection.
- Multi Gateways allow high selectivity for arc, allowing each circuit breaker to be tripped independently of the others, using a low-cost gateway per cubicle.
- 2 configurable digital inputs per Gateway.
- 2 configurable digital outputs per Gateway.
- Dedicated high-speed static contact trip output for tripping the circuit breaker associated with the Gateway + dry contact output for tripping other systems.
- «Chain» input allows chaining for upstream tripping.

### FASES DO ARCO



## TOPOLOGY DESCRIPTION.

Each sensor has a flashing LED to facilitate CAN network communication detection and arc detection.

Each relay can monitor up to 50 ARC SPL sensors.

The low-cost SPL ultraviolet arc sensors are connected through an independent, low-cost Gateway, allowing selectivity for tripping specific circuit breakers in each cubicle.

The Gateway has the function of tripping the associated circuit breaker in the event of an arc flash. Two digital inputs and two digital outputs are also available on each Gateway, allowing tripping or alarm due to external fault or arc chaining, tripping multiple circuit breakers in the event of an arc flash upstream.

The data transmission method between sensors and Gateway uses high-speed CAN physical layer communication, with all sensors connected in parallel using shielded cables with mini-USB connectors that allow for quick installation and operation without the need for any tools.

## ZYGOT ZAG1R/L Gateway + Superger Software

- **Digital Outputs:** 02 Programmable.
- **Parameter programming:** Via «Superger» software (free).
- **Communication:** RS485 serial MODBUS RTU protocol between the various Gateways of the system and the Superger software (Not accessible for communication with the user's DCS\*). CAN port for the sensor network.
- **Protections and Indications:** Modbus communication failure, Arc sensors not responding, Arc Flash trip, Alarm due to Gateway not programmed correctly, Alarm or trip due to ARC Chain, Alarm and Trip due to external fault.
- **Digital Input 1:** Programmable in «None», «Reset».
- **Digital Input 2:** Programmable in «None», «Reset», «Inhibit / Disable Out Trip», «Chain».
- **Programmable Digital Output 1:** «Trip», «Armed», «Alarm», «Remote 1».
- **Programmable Digital Output 2:** «Trip», «Armed», «Alarm», «Remote 2».
- **Parameter programming:** Via PC software (Free).

\* **NOTE.** The complete THM+ARC system has user-accessible Modbus communication, Ethernet and dozens of additional functions, such as event history with real-time clock, reading of sensor voltages on the network, etc.



Detalhe construtivo do Gateway

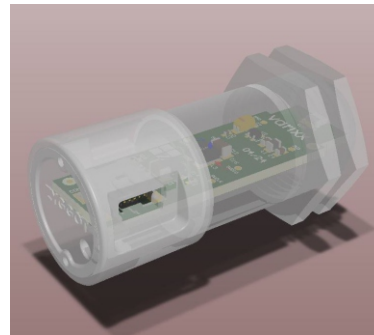

Detalhe construtivo do sensor

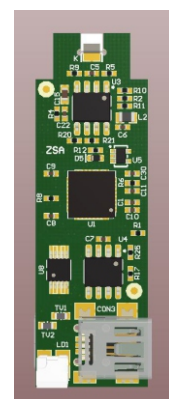
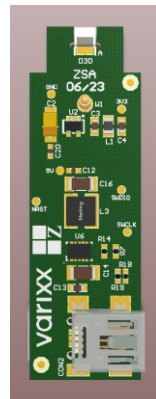
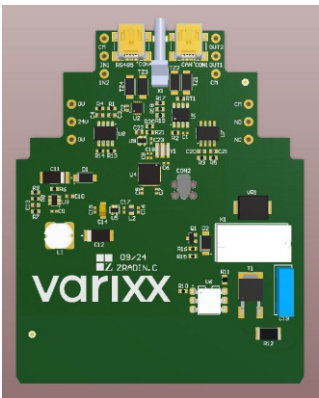

## TECHNOLOGY AND MAIN FEATURES OF THE ZYGOT ARC SPL LOW COST ARC SYSTEM

The low-cost ZYGOT ARC SPL Arc Flash Protection System was developed as a derivative of the standard Zyggot ARC systems with dedicated relay, plus the THM+ARC system with dedicated relay and integrated with the continuous temperature monitoring system. The low-cost ZYGOT ARC SPL system provides the most efficient full-time arc flash protection available worldwide for low and medium voltage electrical equipment such as panels, transformers, motors and generators.

The ZYGOT Arc Flash Protection System in its various versions introduces an important innovation to the market due to the fact that it detects ultraviolet (UV) radiation at the beginning of the arc, i.e., the pilot path, in phase 1 of the arc, before the detection of light from other systems. The light phase is already the final phase of the arc, with expansion of gases and vaporization of copper and other metals. Another important advantage is that selective monitoring of ultraviolet radiation eliminates the need for simultaneous monitoring of the current to confirm the occurrence of the arc, which visible light detection systems require. If ultraviolet radiation is emitted at certain levels, the system can be safely tripped. Systems that detect visible light could be activated by door openings or light entering through cracks, which requires simultaneous current monitoring to prevent inadvertent tripping.

The ZYGOT Arc Flash Protection System, unlike light detection systems, can be applied even under direct sunlight, thus opening up the possibility of using it in external systems (outdoor substations, transformers, motors, etc.).

The sensors have a 90° opening angle that allows monitoring large areas and practically an entire cubicle with a single sensor, since it even detects UV reflected on the internal walls of the panel, thus detecting the start of arcs in areas not directly targeted.

The effective monitoring distances are high due to the high sensitivity of the sensors. Each arc sensor (up to 50 per Gateway in the case of the SPL variant) is connected to a high-speed CAN network connected to the triggering Gateway, which is responsible for providing the trip signal in less than 300 µs.

The interconnection of the sensors to the detection and triggering gateway uses a high-speed CAN network with clean and efficient wiring, unlike star systems, with analog or non-analog signals, which require each sensor to be independently connected to concentrator or interface modules. The high speed of detecting the occurrence of an electric arc and sending the trip signal (300 µs) ensures safety, because in the event of an electric arc, the sooner the energy is removed from the system, the less damage will be caused by the incident energy (up to 150 times less than systems with visible light).

Even if using circuit breakers with an opening time of tens of milliseconds, the system is guaranteed to trip even if the network interconnection cable were destroyed by the arc, since before the destruction the signal would have already reached the relay and the circuit breaker (in dozens of real protection cases that have occurred over many years of using Zyggot Arc systems, no Zyggot system was damaged, due to the high speed of operation, inhibiting the arc and not mitigating it). Another important difference is that the transmitted signals are digital, already processed in the microprocessor sensor and transmitted by shielded cables, and are therefore immune to extremely strong electromagnetic fields generated by the arc current, unlike what can occur with visible light detection systems, with photocell, which transmits analog signal to the interface.

### BENEFITS

- \* Monitors ultraviolet radiation in bands A and B.
- \* Detects phase 1 of the arc, before the visible light phase (i.e. expansion and destruction).
- \* Dispenses with simultaneous current monitoring to determine the occurrence of an arc.
- \* Sends the trip signal in less than 300 µs.
- \* A single Gateway with a state-of-the-art ARM CORTEX microprocessor monitors up to 50 arc sensors.
- \* Reduction of incident energy by up to 150 times.
- \* Low implementation cost.
- \* High reliability.
- \* Allows for high selectivity, if necessary (Multi Gateways).
- \* It does not depend on proprietary software. Just configure it with the Superger software (free) and use it.

### PHASES OF THE ARC

**Pre-Arc:** Ionization of the air and formation of the path for the occurrence of an electric arc. In this phase, ultraviolet light is released (0 to 1 mS). This is the phase in which the arc sensor operates.

**Compression:** The energy of the arc is discharged into the air contained in the room, with a consequent increase in pressure (5 to 15 ms).

**Expansion:** The increase in pressure caused by the previous stage activates the relief mechanism and the air begins to be expelled to the outside, reducing the internal pressure (15 to 40 ms).

**Expulsion:** The pressure inside the room decreases, but the hot air continues to be expelled at an approximately constant pressure. The temperature potentially increases. The expulsion of air tends to be extinguished when the room's environment reaches the temperature of the arc (40 to 60 ms);

**Thermal:** The arc completely affects the insulating materials. The temperature reaches thousands of degrees Celsius and the conductive and structural materials begin to melt. This phase continues until the energy dissipates.

### MAIN FEATURES OF THE SPL SYSTEM

- > Intelligent trigger gateway and relay (with ARM CORTEX microprocessors).
- > Applicable in low and medium voltage.
- > High-speed CAN network for sensors.
- > Gateway with port for connection to PC (Superger).
- > Intelligent arc sensors powered by the CAN network itself.
- > 90° measurement angle.
- > Voltage and sensor status monitoring with superger.
- > Does not require analog interfaces.
- > Gateway, Sensors and Relays can be configured and tested by PC with free software (Superger).
- > Allows high selectivity for tripping, using a low-cost trigger gateway per cubicle/circuit breaker.
- > Up to 50 sensors connected to a single SPL Gateway. (Network with plug-in sensors).
- > Each sensor has a flashing LED indicating communication is OK or faults are detected.
- > Gateway trigger with 3 digital outputs, one TRIP (solid state and mechanical) and two programmable.
- > Easy testing with ArcSafe manual tester (arc generator).

# PRINCIPLE OF OPERATION OF THE ZYGGOT ARC SYSTEM MODEL ARC SPL

## PRINCIPLE OF OPERATION

Each sensor in the system has a high-speed, high-performance ARM CORTEX microprocessor. The firmware embedded in the sensor will operate the communication and other tasks, but if an arc is detected, a high-priority interruption will occur and the arc detection data transmission routine, with the sensor number, will be immediately transmitted to the triggering Gateway. The time from the detection of the arc by the sensor until the activation of the Gateway's TRIP output is less than 300  $\mu$ s, activating a solid-state contact that supports 12 A continuously and up to 200 Amps peak for 5 cycles, plus a dry contact in parallel, allowing rapid actuation plus a guarantee of permanence through the mechanical contact.

The Modbus network connected to the Gateway allows, if desired, to acquire data from the Gateway, without the need for speed since the trip occurs through the Gateway. After detection, the Gateway memorizes the sequence of arc occurrence, or "Arc Chain", if more than one sensor is actuated or there is an arc chain coming from other Gateways. The high-speed CAN network of arc sensors connected to the Gateway provides high detection speed and the fact that the sensors detect the initial phase of the arc ensures that even if the network cable were destroyed by the arc itself, the trip sequence would be terminated, protecting the system from catastrophic destruction (Note: in hundreds of real cases reported by users, this has never happened. The system itself has never been destroyed, unlike light and current detection systems, which frequently suffer from this and there has also never been catastrophic destruction in real cases protected by UV).

The system will be protected even during the LED flash time or any other communication, since the CAN protocol has communication priorities, that is, more than one or even all network elements can generate communication at the same time and the one with the highest priority for all communication of lower priority packets is served immediately. Since the arc detection data packet is the highest priority, the arc detection signal will be read immediately by the intelligent Gateway. If one or more sensors detect arcing, a list of these sensors will be available to the user on the Gateway via Modbus communication. Each Gateway in the system can be configured using free software available on the Varixx website.

## Gateway Trip Output

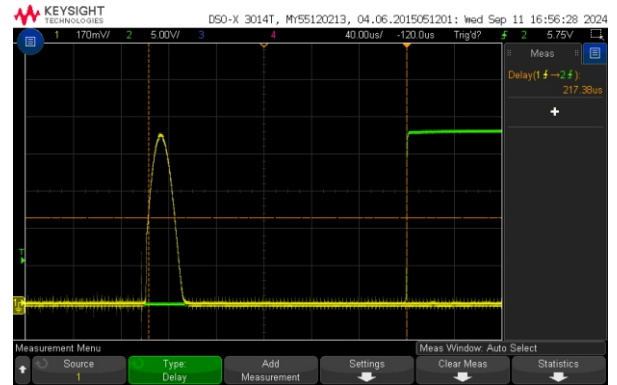

Ocorrência do arco Saída de trip

## READING AND REFLECTION ANGLES

The sensor's opening (detection) angle defines the UV measurement area, i.e. the area where the arc can be detected. UVA and UVB sensors have an opening angle of 90°, covering practically the entire area of a cubicle, depending on the attachment point. In a single-compartment cubicle, a single sensor installed at a suitable point, such as in one of the corners, may be sufficient.

Two sensors at opposite angles leave the entire volume free of shadows. Ultraviolet radiation is reflected from surfaces like visible light (although it can be attenuated). Zyggot sensors can capture reflected UV radiation, which facilitates detection throughout the volume of interest.

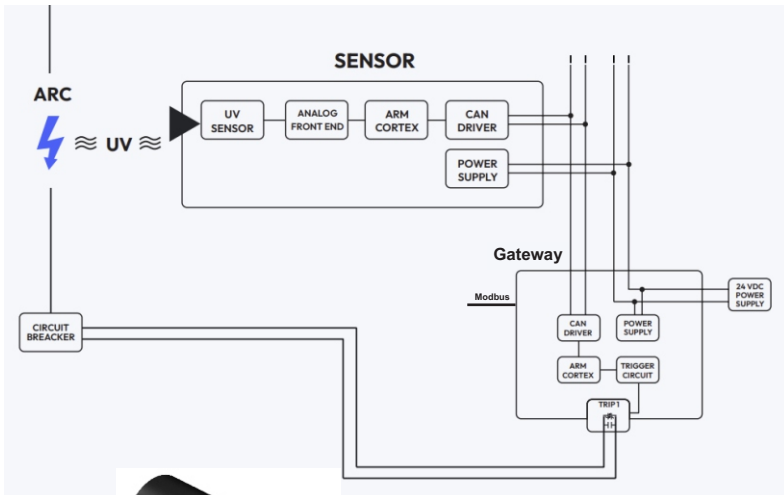

## SPL MODEL ARCH SYSTEM

- A) 90° arc sensor - ZSA/90/24/UVA/SPL
- B) 90° arc sensor - ZSA/90/24/UVB/SPL
- C) ZAG1R/SPL gateway
- F) Interconnection cable with mini-USB connector - ZCB/4/2U/...
- G) 24 VDC power supply VPS12024
- H) Tester (test arc generator) ZSA
- I) Termination resistor ZFR

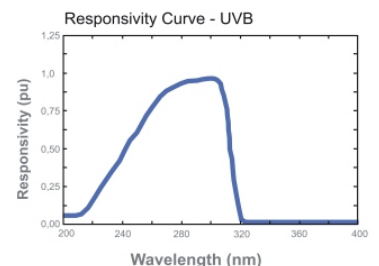
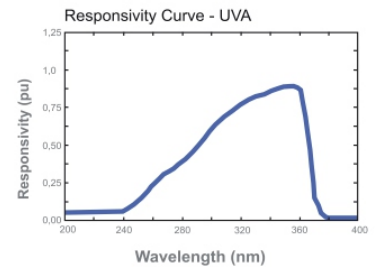

# ZAG1R/SPL GATEWAY OVERLAY AND SIDE LABEL

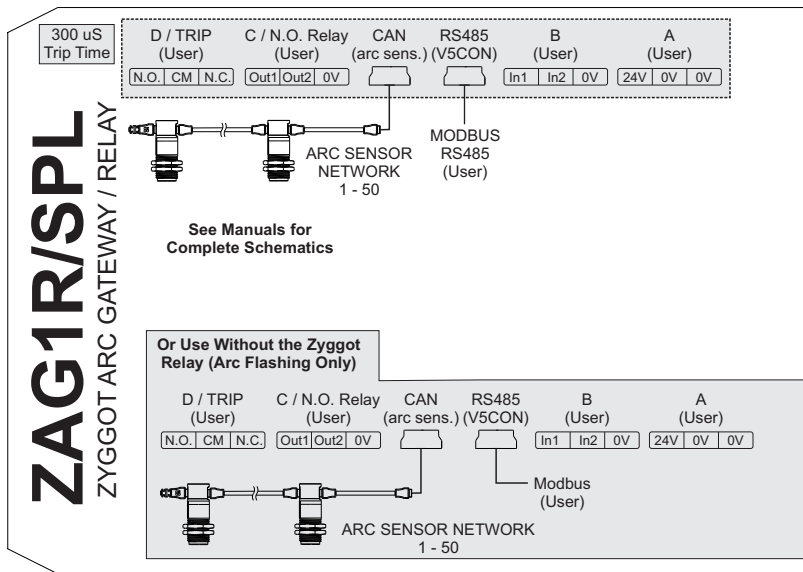
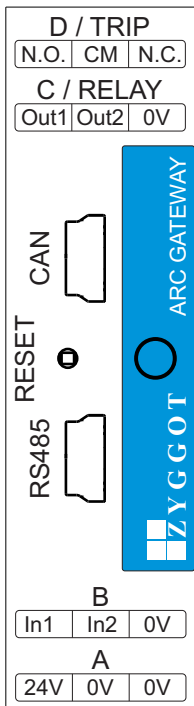

**ZYGOT THM / ARC SYSTEM**  
 Autonomous or Integrated Arc Flashing Relay  
**ZYGOT varixx**

## ZSA/90/24/UVA/SPL Sensor Features

- > Power supply: 24VDC via standard cable.
- > Opening angle: 90°.
- > LED indicator for location and faults.
- > Network addressing configurable via PC.
- > Detects UVA radiation and a small portion of visible light (240 to 340 nm).
- > Applicable in panels and sheltered environments.
- > Does not operate with ambient light or internal light from panels. (It may operate if pointed directly at UV light sources, such as clear sky, sun, flash or intense light).
- > Sensitivity to 2 cm electric arc produced by test device at a distance of 1 to 1.5 m or real arc at up to 30 m\*
- \* Depends on arc intensity (with 200A and 1 cm arc path the detection distance is 7 meters).

## ZSA/90/24/UVB/SPL Sensor Features

- > Power supply: 24VDC via standard cable.
- > Opening angle: 90°.
- > LED indicator for location and faults.
- > Network addressing configurable via PC.
- > Detects UVB radiation (220 to 320 nm).
- > Applicable in panels, open environments or monitoring equipment outdoors.
- > It does not act even with strong visible light (They are also more immune for application in systems with a high incidence of corona).
- > Sensitivity to a 2 cm electric arc produced by a test device at a distance of 0.2 m to 0.4 m or a real arc of up to 10 m\*.
- \* Depends on the intensity of the arc (with 200A and a 1 cm arc path, the detection distance is 3 meters).

## CABLES

The ease of assembling the sensor network lies in the two mini USB connectors present on the sensors and in the shielded mini USB cables supplied in different sizes by Varixx, ready to use.

## PROGRAMMING TOOL

A PC program is provided free of charge by Varixx and allows parameterization and testing of the Gateway and sensors

## GATEWAY COMMUNICATION PORT

The ZAG1R/SPL Gateway has 2 communication ports: One RS485 port, for communication with Superger software on a PC for parameterization and one mini USB port with CAN protocol, for communication with networked sensors.

## GATEWAY DIGITAL INPUTS

The Gateway has 2 digital inputs, 1 for Reset and 1 programmable by the relay or by the PC software. The "Reset" contact, if closed momentarily, performs the function of erasing the Gateway's alarms and trips, also erasing the Arc Flash occurrence sequence data.

## DIGITAL GATEWAY OUTPUTS

The Gateway has 3 digital outputs, 1 for TRIP and 2 programmable by the relay or by the PC software. The trip output has an ultra-fast acting solid state relay and another N.A. dry contact in parallel. The programmable outputs are normally open dry contact type.

## GATEWAY INDICATOR LED

The Gateway has 1 RGB LED, which will be «Green» if the gateway is programmed, configured and without alarms or trips. It will be «Yellow» in case of occurrence of alarms or trips that have not been reset or will be «Red» in case of a Trip that has not been reset.

**NOTE:** An Alarm condition due to "Sensor not responding" does not deactivate the "Armed" condition and the consequent deflection in case of arcing in other sensors in the network. For safety reasons, the system, even in alarm, will be active for Arc Flash detection.

## CONECTOR MINI USB MULTI-FUNÇÃO DO SENSOR

The mini-USB connectors on the sensor are used both for parameterization, using a standard mini USB / USB cable (supplied separately) and a PC, and for communication with the Gateway via the network cable (supplied ready to use, in lengths from 30 cm to 8 meters). The sensor's mini USB ports are parallel, so there is no difference between which port to connect the cable to. The dual mini-USB port makes network assembly easier. For details on how to parameterize the sensor, see the programming section.

## CAUTION

Do not connect the sensor to the computer with the other end of the sensor connected to the sensor network. This may damage the sensor and the computer!  
For parameterization, one sensor must be connected to the computer at a time.



# SYSTEM DETAILS RELATING TO ZYGGOT ARCO SPL SYSTEM

## CABLE LENGTH SELECTION OF EACH SENSOR AND THE NEXT

The sensors are connected to the network using a shielded sleeve-type cable, without the need for any tools. These cables, which already have a mini USB connector on both ends, are supplied by Varixx in various lengths.

Below are the available codes and sizes.

ZCB/4/2U/030	Cabo de conexão dos sensores 0,3 m
ZCB/4/2U/050	Cabo de conexão dos sensores 0,5 m
ZCB/4/2U/100	Cabo de conexão dos sensores 1 m
ZCB/4/2U/200	Cabo de conexão dos sensores 2 m
ZCB/4/2U/400	Cabo de conexão dos sensores 4 m
ZCB/4/2U/600	Cabo de conexão dos sensores 6 m
ZCB/4/2U/800	Cabo de conexão dos sensores 8 m

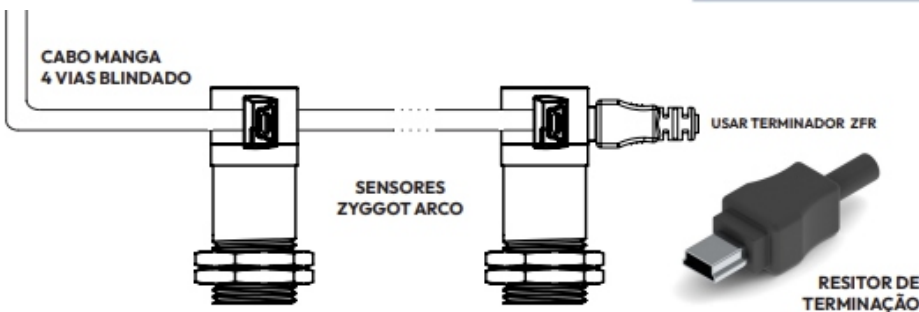

## TRANSIENT SUPPRESSOR IN THE GATEWAY TRIP CONNECTION

It is mandatory to use a type of transient suppressor compatible with the type of load. For trip coils (highly inductive), it is recommended to use a Varistor with appropriate characteristics. Possible variations for this circuit are "Free Wheeling Diode" (for DC power) and "Snubber" circuit composed of Resistor and Capacitor. This minimizes the generation of arcs in the 52a contact of CB1 and noise, increasing the useful life of the system and avoiding interference and improper operation of other equipment. If in doubt between the types of circuit, use the varistor. Consult the Circuit Breaker Manual.

## ZYGGOT SPECIFICATIONS

Arcing Sensors	(No Contact)
Tightening	2 x Nuts
Power Supply Types	By CAN Network
UV Wavelength	200 to 320 nm
Case Type	Stainless Steel
Sensor Measurement Angle	90°
Radiation Rages	UVA and UVB Insensible to visible and IR
Sensor Transmission Type	High Speed CAN
Temperature Operation	-20 to 89 °C
Temperature Storage	-40 to 125 °C
Maximum Measurement Range (distance from sensor to target)	30 m depending on the Arc Power
Max. CAN Cable Length	500 m
Configuration (Address, Sensitivity)	By Computer with Free Program
Indication	Led at rear face
Max. Sensors per Gtwy SPL	50
CE	Compliant

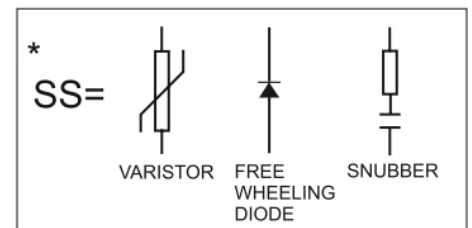

# EXAMPLE OF TYPICAL APPLICATION WITH 115 VAC / 125 VDC TRIP COIL

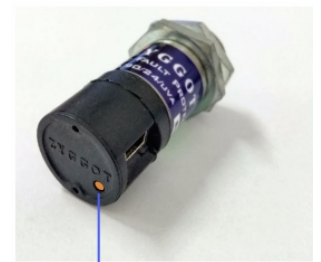
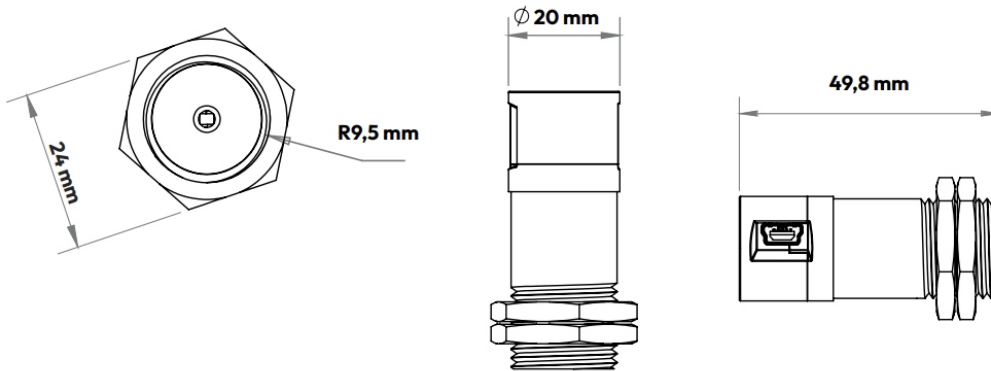
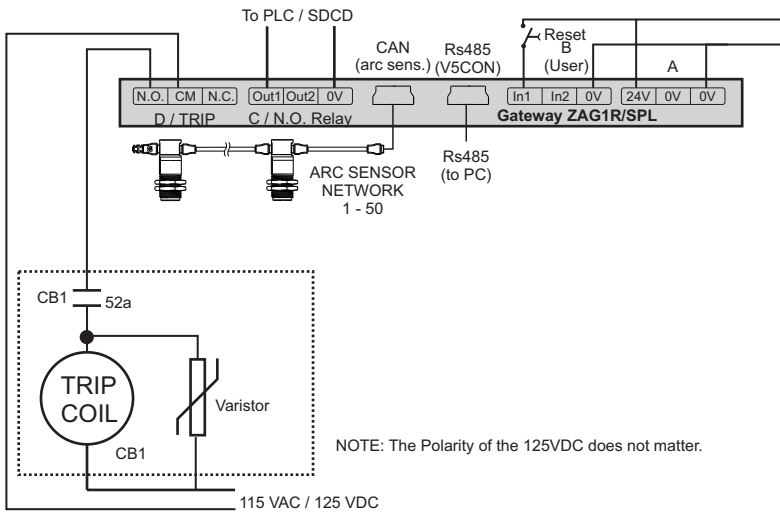

YELLOW LED

## PROGRAMMING THE SENSORS

- 1 - Download and install the free software "ZyggotArc Configurator" from the Varixx website (<http://www.varixx.com.br>).
- 2 - Open the configuration program.
- 3 - Connect the sensor to the computer's USB port using a mini USB / USB cable (connect one sensor at a time). When the sensor is connected, its back light will turn on. The program automatically detects the sensor. If this does not happen, you can choose manual connection, choose the serial port corresponding to the USB to which the sensor cable is connected and press the Connect key to attempt a connection. When connecting (in both manual and automatic mode), a green light will turn on in the program indicating that the connection was successful.
- 4 - Program the sensor address (from 1 to 50 in the case of the SPL version) in the corresponding window and press «Send» to save the information to the sensor. Disconnect the sensor by simply removing it from the cable.
- 5 - It is advisable to label the sensor with its programmed address to make it easier to assemble in the field. If you wish to configure another sensor, return to step 3. Then check that there are no duplicate addresses between the sensors.
- 6 - Once all the sensors have been programmed with the addresses, fix the sensors in the defined positions using the two nuts on the front of the sensor. As a suggested assembly, we recommend using our metal "adjustable fixing bracket" (REF. ZSF2), with adjustable angle, which allows the use of just one Boelhoff rivet or similar in the chosen location, to fix the sensor and direct it.



# EXAMPLE OF TYPICAL APPLICATION AND BASIC SYSTEM COMPOSITION

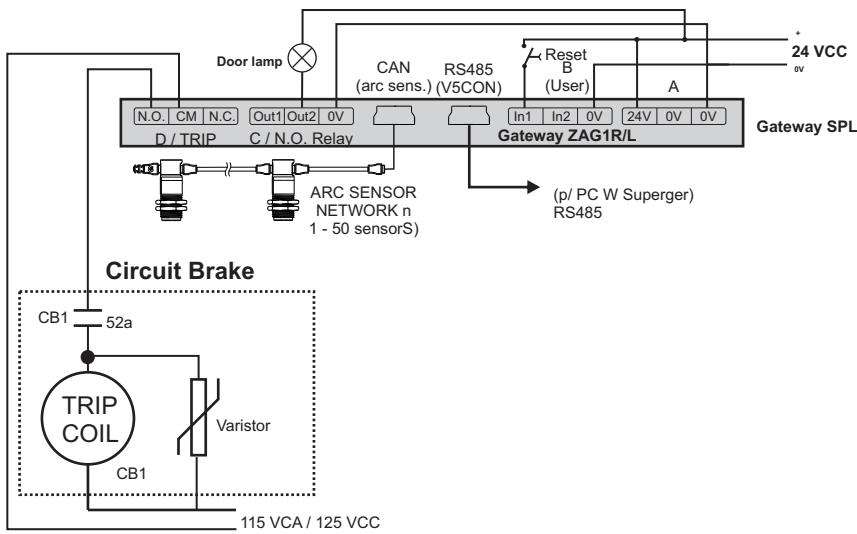

NOTE: The Polarity of the 125 VDC does not matter.

In cases where high selectivity is required, such as in cases of distribution branches with one circuit breaker per branch, the side topology can be used with multiple triggering Gateways, each one triggering its own associated circuit breaker, each one with up to 50 arc sensors, i.e. configuring a low-cost, high-efficiency system (Multi Gateways). Each Gateway sends the «TRIP» signal to its circuit breaker in less than 300 uS.

Note that it is possible to use only one Gateway with its sensors, which can be from 1 to 50. Typically, one Gateway per cubicle, associated with its circuit breaker, and 1 or two Zyggot UV Arc sensors would be enough to have each cubicle fully protected against Arc-voltaic.



**Technical information**

**FEATURES: ARC UVA SENSOR**

Measuring angle:	90°
Power Supply:	24 VCC by the NET
Detection range:	UVA (240 to 380 nm)
Test sensitivity:	1 to 1,5 m (w/tester ZSA)
Real Arc Sensitivity:	up to 30 m
LED status indicator:	Included
Settings:	By PC software
Diameter:	19mm
Length:	53mm
Communication:	Rede CAN 512 MBs
Material:	Stainless Steel and Polycarbonate

**Technical information**

**FEATURES: ARC UVB SENSOR**

Measuring angle:	90°
Power Supply:	24 VCC by the NET
Detection range:	UVB (220 to 320 nm)
Test sensitivity:	1 to 1,5 m (w/tester ZSA)
Real Arc Sensitivity:	up to 30 m
LED status indicator:	Included
Settings:	By PC software
Diameter:	19mm
Length:	53mm
Communication:	Rede CAN 512 MBs
Material:	Stainless Steel and Polycarbonate



# PROGRAMMING SENSORS WITH ZYGGOT SUPERGER SOFTWARE

## PROGRAMMING - ZYGGOT ARCO SENSORS

Zyggot Superger is a configuration software that addresses and tests sensors, as well as parameterizes and configures Zyggot relays for versions other than SPL. The software is available for free download from the Varixx website (<http://www.varixx.com.br>). The figure below shows the home screen of the Zyggot Superger software.

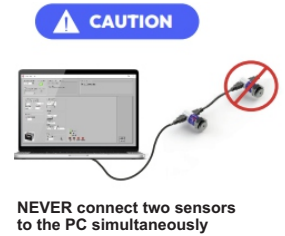

**NEVER** connect two sensors to the PC simultaneously



The software automatically recognizes the device and the port to which it is connected to the computer. If the port is not recognized, you can manually select the port using the Manual Connection box. When choosing to connect manually, you must select the serial port to which the device is connected and press the Connect button. When a sensor is connected to the computer, the program screen automatically changes to the image below. When connecting a sensor, the program automatically reads the address settings.

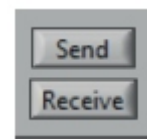
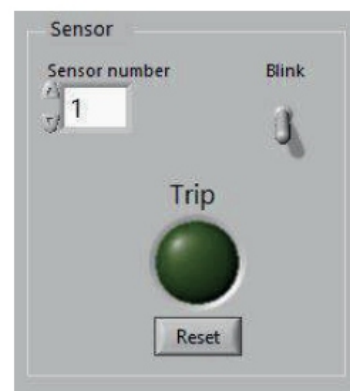
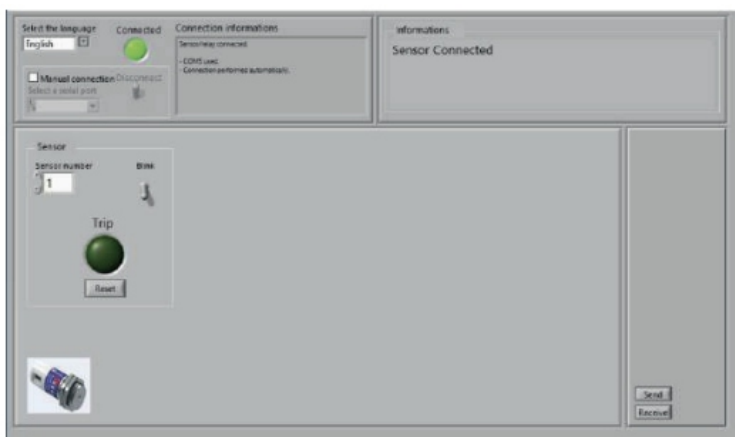

To set a new address for the sensor, you must change the sensor number in the Sensor tab. When you do this, the sensor number will flash red, indicating that the change has not yet been sent to the sensor. To save the change, press the Send button.

The Sensor tab also provides the sensor's Trip indicator. If you want to test the sensor, use the ArcSafe tester to generate an arc in front of the sensor. When an arc is detected, the Trip indicator will change to red, and the LED on the back of the sensor will flash for a few moments. To restore the sensor status, press the Reset button. Use the Blink key to make the LED on the back of the sensor flash indefinitely. Press again to stop.

Quando desejar desconectar o sensor basta removê-lo da porta mini USB.

# USING THE ARCSAFE ZSA TESTER

## OPERATION TEST USING ARCSAFE TESTER (ZSA)

The ArcSafe tester generates very low current arcs, which represents a low risk of injury. However, the risk is not zero, and can cause serious muscle damage and even death, especially if the operator is in special conditions such as high places or confined spaces, which can lead to falls or collisions with objects or live parts and involuntary movements in the event of an impact. Use the ZSA with extreme care and attention.

Always turn off the slide switch when it is not in operation. Only turn on the switch just before each test and turn it off immediately afterwards. Each time the switch is turned on, the front light will flash and the LED to indicate that it is on will light up.

The figure on the side shows the ArcSafe Varixx tester (supplied separately) for testing system operation. The ArcSafe is rechargeable in a 110 or 220 VAC outlet. The equipment generates an extra high voltage (3,800,000 Volts) generating small low-energy electric arcs between its electrodes, which are detected by the sensor up to an average distance of 1 meter (UVA sensor) within its viewing angle. You can hold down the trigger button to generate a sequence of arcs (the arc detection by the sensor and relay will always be on the first arc) or quickly press the button to generate a single arc.



**WARNING**



**CAUTION**

## HOW TO RUN SYSTEM TEST WITH ARCSAFE GENERATOR

- Assemble the system completely and make sure that the relay is indicating Armed, that is, monitoring the occurrence of an arc. In this condition, there will be no indication of previous trips.

Note that the condition of sensors not responding only activates the Alarm output, not preventing the Armed condition, since even with some sensors in the network not responding, others may be operational and active. It is highly recommended to use the Alarm output for indication on the DCS system or panel door.

- For each sensor to be tested, position the ZSA arc generator in front of the sensor, within the 90° viewing angle, that is, up to 45° from the straight line extending from the center of the sensor.

Remember to comply with the maximum detection distance of the tester for UVA (1.5 m) and UVB (0.2 m) sensors.

Note: in the case of a real arc, the detection distances are greater due to the large amount of energy released in UV radiation. Real arcs can be detected at a distance of up to 30 m\*.

- Preferably generate a single arc by quickly pressing the ArcSafe trigger button.

- The arc will be detected and the Trip output will be activated, with the Trip LED on the relay and the corresponding sensor indicating the arc. (The rear LED on the sensor will also flash for a few moments).

- After checking that it is operating correctly, reset the relay by pressing and holding the front RESET/ENTER button or the RESET/INHIBIT contact for a few moments.

- Repeat the test operation for each sensor in the system.

\* Maximum detection limit for sensors. The actual detection distance of an arc depends on the intensity at which the arc occurs.

## CAMERA FLASH TEST

Common camera flashes are also a spark gap in an inert gas bulb, and so most flashes emit ultraviolet light in addition to visible light. More modern LED flashes also have a percentage of ultraviolet light.

UVA sensors can detect some of these flashes, while UVB sensors have a lower detection spectrum and are therefore more immune to photographic flashes.

Note: Not all photographic flashes emit UV radiation.

# ACCESSORIES

**Accessory**

COD: VPS6024 ou VPS12024



**POWER SUPPLY**

**Accessory**

COD: ZSF2



**Support for fixing and sight for tubular**

**Accessory**

COD: VZX/B1/U ou VZX/B1/U/P



**SUITCASE WITH LASER SIGHT**

**Accessory**

COD: ZFR

COD: ZTA



COD: ZCB4/2U/xxx

**Y-split Derivator, USB cables and terminating resistor**

**Accessory**

COD: VLP2



**Laser sight attachable to tubular sensor for startup**

**Accessory**

COD: RJ45/C2  
(Comes with each V5CON module and each Eblock)



**RJ45 CABLE**

**Accessory**

COD: ZSA



**ARCSAFE Arc Tester**

## ABOUT VARIXX

For over 40 years, Varixx has pursued its vocation for developing high-tech products and focuses its efforts on serving the industrial market with quality and speed. Our know-how in power electronics has allowed us to offer the market a wide range of products that have become known for their long service life and reliability. We were the creators of the global online thermography market, with the Zyggot line, which is becoming a global reference in the market for temperature monitoring and diagnostics and arc flash detection in electrical systems in general.

Our product portfolio also includes LED luminaires from our ONNO division, developed and manufactured 100% in Brazil with cutting-edge technology. Varixx values the introduction of innovative concepts worldwide.

## AREAS OF ACTIVITY

- ✓ **MANUFACTURERS OF GENERATOR MACHINES AND SYNCHRONOUS MOTORS**  
Static Exciters, Control Box Controllers, Low and Medium Voltage Soft Starters, Semiconductors
- ✓ **PRODUCTION OF ALUMINUM AND HYDROGEN / OXYGEN**  
High Current Rectifiers, Solid State Contactors, Smart Relay for CCM, Online Thermography System and Arc Flash Detection and Onno LED Luminaires.
- ✓ **BASE INDUSTRY, MINING AND STEEL INDUSTRY**  
Smart Relays for CCMs, Low and Medium Voltage Soft Starters, Solid State Contactors, AC/DC Converters for electromagnets, High Current Rectifiers, Online Thermography System, Arc Flash Detection and Protection and Onno LED Luminaires.
- ✓ **OIL COMPANIES**  
Smart Relays for CCMs, Static Excitation, Low and Medium Voltage Soft Starters, Solid State Contactors, Online Thermography System, Arc Flash Detection and Protection and Onno LED Luminaires.
- ✓ **ELECTRIC PANEL ASSEMBLERS**  
Smart Relays for CCMs, Online Thermography, Arc Flash Detection and Protection System, Semiconductors, Power Supplies and Onno LED Luminaires.

## Why ZYGGOT Thermography And Arc Flash Protection?



**SINGLE CABLE / EASY TO INSTALL**



**PREDICTIVE / DIFFERENTIAL PROTECTION**



**EFFECTIVE PROTECTION AGAINST ARC DESTRUCTION**



**WORLDWIDE UNIQUE BY UV DETECTION / NO CURRENT READING REQUIRED**



**DOES NOT NEED CONVENTIONAL THERMOGRAPHY / ALSO MEASURES AIR TEMP.**



**WITHOUT CONTACT / WITH NETWORK COMMUNICATION**

## LEARN MORE!

### ZYGGOT ARC FLASH SYSTEM

- ✓ **Low Cost // Up to 100 sensors per relay.**
- ✓ **Innovative in the market // Faster (<300 uS versus up to 500 mS)**
- ✓ **Ultraviolet arc detection**
- ✓ **Does not operate with ambient light (False Alarm)**
- ✓ **No need current reading**

# varixx

ALWAYS INNOVATING

www.varixx.com.br  
vendas@varixx.com.br  
+55 (19) 3424-4000  
+55 (19) 3301-6900

R. Felipe Zaidan Maluf, 450  
Distrito Industrial Unileste  
Piracicaba-SP. CEP: 13422-190



@Varixxbrasil



@varixxcompany



Varixx Indústria Eletrônica



www.varixx.com.br

Representante/Distribuidor:



ZYGGOT THERMOGRAPHY

## VARIXX USA

2229 Allen Parkway, Suite 200  
+1 832-871-5700  
Houston - Texas, 77019

## VARIXX WORLDWIDE

MORE THAN 20 BRANCHES,  
DISTRIBUTORS AND REPRESENTATIVE  
OFFICES WORLDWIDE