

ZYGGOT RADDIA TS ONLINE RADIO THERMOGRAPHY SYSTEM

ONLINE THERMOGRAPHY - CONTINUOUS TEMPERATURE MONITORING

RADDIA TS - MANUAL

RADIO CONTINUOUS TEMPERATURE MONITORING PROTECTION SYSTEM

W/ ETHERNET



ONLINE THERMOGRAPHY SYSTEM
FOR LOW AND MEDIUM VOLTAGE APPLICATIONS

INDEX

| | |
|--|----|
| DESCRIPTION | 3 |
| KEY POINTS | 4 |
| TECHNOLOGY AND TECHNICAL DETAILS | 5 |
| PRODUCT COMPOSITION | 6 |
| ACCESSORIES AND SPARE PARTS | 7 |
| V5CON INTERFACE DETAILS | 8 |
| SINGLE-LINE DIAGRAM AND MAIN FEATURES | 9 |
| TYPICAL CONNECTIONS | 10 |
| CONNECTIONS | 11 |
| TYPICAL NETWORK AND INSTALLATION DETAILS | 12 |
| MECHANICAL | 13 |
| TECHNICAL CHARACTERISTICS | 14 |
| TECHNICAL SPECIFICATIONS | 15 |
| MAIN SCREENS FOR OPERATION | 16 |
| PROGRAMMING | 31 |
| TESTING THE ETHERNET CONNECTION | 51 |
| OPERATION | 52 |
| SCREENS FLOW | 54 |
| REPORT | 59 |
| PROGRAMMING - PROGRAMMING MENU 1/2 | 62 |
| PROGRAMMING - PROGRAMMING MENU 2/2 | 63 |
| COMPUTER PARAMETERIZATION - ZYGGOT SUPERGER..... | 64 |
| CONFIGURATION | 68 |
| FAIL SAFE SYSTEM | 69 |
| HOW TO DO IT | 70 |
| SUPERVISORY SOFTWARE | 72 |
| MODBUS | 75 |
| MODBUS - MEMORY MAP | 85 |
| MODBUS OVER ETHERNET TCP IP SERVER | 89 |
| ABOUT VARIXX | 98 |

Note: This manual is written in English and the same manual is also available on the website varixx.com and varixx.com.br in Portuguese (PT=BR). The Zyggot relay leaves the factory with 3 selectable languages, English, Portuguese and Spanish, and can also be supplied with other languages, upon request.

ZYGGOT THERMOGRAPHY

TEMPERATURE MONITORING SYSTEM



RADDIA TS Sensor

Receiver / Repeater
RADDIA TS

ZYGGOT RADDIA TS Relay

Unscaled photos

DESCRIPTION

The RADDIA TS system is designed to allow online monitoring of the temperatures of low and medium voltage components and internal connections, transformers, motors, etc., by transmitting radio signals. The RADDIA TS series wireless temperature measuring sensor is designed in accordance with the specification for wireless temperature measuring equipment. It is suitable for low voltage switchgear from 440 V to high voltage up to 35 kV of any type. The wireless temperature sensors can be installed at any point where heating is possible. The device uses wireless data transmission technology for real-time transmission of monitored temperature data. In addition, it can be transmitted to the Zyggot relay or DCS remote intelligent monitoring system. The RADDIA TS system, together with its brother company Zyggot, continues a history of important innovation in the market, since current safety standards prohibit the opening of energized electrical panels for any type to make measurement, including temperature measurements with manual measuring guns or thermography cameras.

The RADDIA TS system allows for “On Line” temperature monitoring of multiple points per relay.

Different Alarm and Trip levels allow for the optimization of the protection system. Each relay can monitor up to 125 sensors.

The relay has the function of reading the temperature values of the sensors. Four digital outputs are available, all configurable.

The data transmission method between sensors and relay uses radio communication at 433/470 MHz, which allows for quick installation and operation.

The RADDIA TS system relay can be connected to a communication network with a supervisory system or remote monitoring.

The Relay has Ethernet communication with various protocols, and can be accessed from anywhere by mobile or non-mobile devices.

APPLICATION

Temperature monitoring and “On Line” protection of electrical connections and components for low and medium voltage electrical panels, transformers, etc.

BENEFITS

- * Prevents opening of the energized panel.
- * Dispenses with periodic thermography.
- * Provides readings of up to 125 points.
- * Radio signal transmission.
- * Indicates any sensor failure.
- * Failure history.

Characteristics of the RADDIA TS System

- * Applicable in low and medium voltage up to 35 kV.
- * Receiver and Repeater network and Relay with Modbus Rs485.
- * Sensors powered by the bus current (C.T.)
- * Sensors with battery can be optionally supplied (readings every 5 minutes at 25 °C or up to 25 s at 80 °C).
- * Operating start current: >5 AC
- * Measurement from -40°C to 125°C.
- * Sensor ambient temperature: -40 to 125°C.
- * Receiver ambient temperature: -30 to 105°C.
- * Readings: Every 15 s.
- * Accuracy: +/- 1°C
- * Resolution: 0.1 °C
- * Receiver communication distance: 150m in open area. * «Repeater» communication distance: 1000 m in open areas.
- * Relays with color graphic touch screen display and Modbus and Ethernet communication.
- * Fault history with “Time Stamp”.
- * Reading and over-temperature protection of up to 125 points per relay.
- * Readings and protections related to 4 analog inputs per relay.
- * External fault monitoring.
- * Sensor status monitoring.
- * 4 + 8 programmable digital inputs.
- * 4 + 8 programmable digital outputs.
- * Sensor can be fixed with screws (no risk of falling).
- * «Fail Safe» operation of the relay.
- * Receiver Output: 2 passive 5A / 250 VAC 5A/ 30VDC
- * Relay protocols:
MODBUS RTU: Modbus via serial communication.
TCP/IP (Modbus Slave): Modbus over Ethernet).
FTP: (File Server) File Transfer Protocol.
NTP Protocol: Network Time Protocol

KEY POINTS

MAIN ADVANTAGES

WITH ETHERNET

WITH MODBUS RTU

PREVENTS PANEL OPENING

AVOID NORMAL THERMOGRAPHY

EASY INSTALLATION-125 S. PER RELAY

RADIO TRANSMISSION

DOES NOT USE BATTERIES

FULLY CONFIGURABLE

MULTIPLE SIGNAL REPEATER

HISTORY OF EVENTS

PLOT DE TEMPERATURAS

KEY POINTS

- Color Touch Screen.
- Has Ethernet communication with several protocols.
- Several built-in protections.
- Real-time graphic recording (Plot).
- History of failures and events.
- Continuous temperature readings of up to 125 points.
- Modbus RTU communication.
- Each relay presents continuous measurements of up to 125 points.
- Prevents opening of energized panel for possible thermography.
- Transmission of temperature signals by radio.

APPLICATIONS

- Internally to electrical panels for continuous temperature monitoring.
- Transformer Supervision.

MAIN FEATURES

- Reads temperatures of up to 125 points per relay.
- Configurable alarm and trip levels for temperature and analog inputs.
- Real-time graphical recording for temperatures and analog inputs.
- Detection of differential temperature increases integrated into the relay and configurable by the user.
- History of faults and status.
- Continuous readings.
- 4 analog inputs with configurable alarm and trip levels.
- 4 + 8 digital inputs for external events or faults (ventilation, doors, etc.).
- 4 + 8 configurable digital outputs.
- Modbus RTU + Ethernet TCP IP. (All data accessible via Ethernet)

The RADDIA TS system with sensors that transmit signals via radio was developed for low and medium voltage panels. The sensors measure temperature with physical contact and allow online readings for up to 125 points per relay. They communicate with Receivers/Repeaters that are connected to an RS485 Modbus RTU network. The relay provides local protection and also through a supervisory system. Alarm and trip levels are freely programmable for each point. A possible failure in one of the sensors does not interrupt the operation of the other sensors.

It can be fixed by the metal tape itself or by 2 screws (prevents the risk of falling and allows the tape to be changed and also relieves the tension of the metal tape that makes up the "Energy Harvesting" system by C.T.).

ZYGGOT RADDIA TS RELAY.

- **Digital Inputs:** 04 on the relay + 8 on the eBlock module.
- **Digital Outputs:** 04 on the relay + 8 on the eBlock module.
- **Programming of parameters and values:** "On line".
- **Reading of Values:** Temperature of each point, Analog Inputs.
- **Communication:** Serial RS232C and RS485 MODBUS RTU protocol for "Point to Point" connection, for use in network (Droop Out). CAN port with optional Devicenet Protocol.
- **Protections and indications:** Alarm due to point over-temperature, Alarm due to point differential heating, Communication failure with the "Receivers" network, Modbus communication failure, Sensors not responding, Alarm and Trip for up to 5 groups of independent sensors, Alarm and Trip due to external failure, Alarm and trip due to analog input levels, Alarm due to memory card failure, Active alarm screens, History screen with "Time Stamp", Bargraph with "Receivers" being read, Alarm and trip statistics, Digital input and digital output status, Analog input levels, Temperature plot for each sensor and analog input, Indication of Temperature Differential and Percentage of each sensor in relation to programmable time.
- **Fault actions:** Programmable for each fault in "None", "Log", "Alarm", "Trip".
- **Real Time Clock:** Included.
- **Failure History:** with Date and Time.
- **Event Memorization:** Unlimited events, memorized indefinitely until they are cleared with a password, for security.
- **Fail Safe System:** Yes
- **Memory Card:** Automatic and manual recording of temperature reading data on the memory card for transfer to computers.
- **Failure History:** with Date and Time.
- **Active screens:** more than 200 multiple screens.
- **Parameter programming:** By the relay itself, with passwords, by PC software (Free), by replication via memory card (program one and replicate it on all the relays in the system) or by Modbus (optional).

Power supply

The Zyggot RADDIA TS system, with regard to Receivers and Relays, must be powered by an external source. The VPS12024 source has the capacity to supply 24 VDC.

The sensors do not require power.

Input: 90~132 / 180~264 VAC // 120~375 VDC
Output: 24VDC/5A - 120W

PROTECTIONS AND FUNCTIONS

| ANSI | DESCRIPTION | TRIP | ALARM | Monitor |
|------|-----------------------------------|------|-------|---------|
| 94 | 2 x Assignable External | | | |
| 49 | 125 Points Overtemperature | | | |
| 49 | 125 Sensor Status. | | | |
| | 125 Differential Temperature | | | |
| 30 | Anunciator w/ Time Stamp | | | |
| | Event Recorder - 120 Tags | | | |
| | Readings 4 External Analog Signal | | | |
| | Readings Receiver Temperature | | | |
| | Readings - 125 Sensor Integrity | | | |
| | Trendings - Real time curves | | | |

CODE: VZX/RADDIA/TS/L or VZX/RADDIA/TS/F

RELAY 96 X 125 Touch Screen

Technical Information

FEATURES: RADDIA TS RELAY

| | |
|----------------|--|
| Power Supply | 24 Vcc |
| Humidity | 5 to 95% |
| No. of sensors | up to 125 sensors |
| Resolution | 0.1°C |
| Inputs | 4 analog 4 digital (12 to 24Vdc) |
| Outputs | 2 Alarm and Trip outputs (N.O.) 2 programmable outputs (N.O.) 1 connection to Receiver |
| Communication | Modbus RTU Devicenet (optional) Ethernet TCP-IP (optional) |
| Screen | Color, Touch Screen WVGA |

RELAY
The systems are available in 2 models.
VZX/RADDIA/TS/L: Relay with color touch screen.
VZX/RADDIA/TS/F: Same as L but with expansion module for 12 digital inputs and 12 digital outputs.

CODE:

RADDIA TS SENSOR

Technical Information

FEATURES: EBLOCK 88x (x=D or x=R)

| | |
|----------------------------|--|
| Power Supply | 24 Vdc (10 - 30 Vdc) 2W |
| Humidity | 5 to 95% |
| Communication | CAN |
| Temperature | Oper: 0 to 60 °C /// Stored: -10 to +60 °C |
| Inputs | 8 Digital IMputs (12 to 24 Vdc) |
| Outputs | Model 88D = 8 Digital Output (DC) Modelo 88R = 8 Digital Output (Relay) |
| Input | Imp.: 10K /// Treshold: 8 VDC / 3 VDC |
| Max Distance | 1000 M |
| Current output (Model 88D) | 2,5 A Max per point /// Max 10A Total (model 88D) |
| Output (mod 88R) | 3,0 A @ 250 VAC Res. Max (mod. 88R) |

COD: V5CON
(Included with each Relay)

INTERFACE

CODE:

RADDIA TS/RS RECEIVER

Technical Information

FEATURES: RADDIA TS SENSOR

| | |
|-----------------------|-----------------------|
| Signal transmission: | Radio 433 / 470 Mhz |
| Precision: | +/- 1C |
| Sampling Time: | 15 s |
| Reading Type: | By direct contact |
| Resolution: | 0.1°C |
| Point reading: | -50 to 125 °C |
| Operating Ambient T.: | -30 to 105 ° |
| Power Supply: | per C.T. > 5 A AC |
| Depth: | 17 mm |
| Length: | 32.5 mm |
| Width: | 32.5 mm |
| Material: | Metal & Polycarbonate |

CODE: VPS6024 or VPS 12024

24 VDC POWER SUPPLY

CODE:

RADIO REPEATER TS/RR

Technical Information

FEATURES: RS RECEIVER

| | |
|-------------------------|---------------------------|
| Communication: | RS484 Modbus RTU |
| Radio Frequency: | 433 / 470 Mhz |
| Outputs: | 2 x Passivos 5A / 250 VAC |
| Maximum sensors N.: | 125 |
| Resolution / Precision: | 0.1°C / 1°C |
| Operating Ambient T.: | -20 a +55 °C |
| Measuring range: | -50 a +125 °C |
| Power Supply: | 12-48 VDCV / 100-265 VAC |
| Consumption: | < 2W |
| Dimensions: | 90 W x 38 L x 90 D |
| Communication: | Modbus RTU |
| Material: | ABS |

NOTE: The RADDIA TS sensor is sold and packaged in boxes of up to 10 units, as shown in the photo on this page. The metal tape is made up of 3 thin layers for optimum flexibility and when folded in half along its entire length it becomes 6 layers, passing internally into the cavity of the Raddia TS sensor. In this way it can embrace busbars up to 10 inches wide x 1 inch thick or circular ones up to 7 inches in diameter. When attaching the tape to smaller busbars, the excess can be cut off if desired. In this way, the minimum operating current is 3 Amps.
If it is necessary to use it on larger busbars, the bundle of metal tapes can be used without folding in half, thus reaching busbars twice the size, in which case the minimum operating current will be 6 Amps. Note that such large busbars will certainly have much higher currents than this.
See installation details later in this manual.

CODE:

Sensor With Metal Tape

Technical Information

Connectors: EB/88D & EB 88R

| | |
|----|---------------------------------|
| 1: | Digital Outputs / Relay Outputs |
| 2: | Network Address Selection Keys |
| 3: | Status LEDs |
| 4: | Inputs |
| 5: | CAN and Power Supply |
| 6: | Ground |
| 7: | CAN RJ45 |

ACCESSORIES

Accessory

CODE: VPS6024 ou
VPS12024

POWER SUPPLY

Accessory

CODE: RJ45/C2
(Included with each
V5CON and with each Eblock)

Rj45 CABLE

Accessory

CODE: ZA232-2

RS232 / RS485 SPLIT

Accessory

COD: V5CON
(Included with
each Relay)

Interface

Accessory

CODE:

PHOTO NOT AVAILABLE

**CORRUGATED METAL TAPE WITH
QUICK FIXING SYSTEM**

NOTE: The **RS232/RS485 SPLIT** can optionally be used connected to the MJ1/MJ2 port of the relay to duplicate it and have access to the RS232 connection, since the RS485 connection is used to connect to the V5CON interface which also adds two more RS485 ports for the user. An RS232 connection can be used to connect a computer for example, but it is not normally used on the factory floor, but rather RS485 because it can be carried over much greater distances and is immune to interference.

EBLOCK DETAILS

The EBLOCK 88D module adds 8 digital outputs and 8 programmable digital inputs to the Zyggot Raddia relay. The EBLOCK 88R module adds 8 relay outputs (dry contacts) and 8 programmable digital inputs to the Zyggot Raddia relay. These modules (one or the other) are only used in the Raddia relay and are not used in the Raddia relay.

| Digital Outputs | | |
|-----------------|--------|-----------|
| D. OUT. 1 | ALARM | Q1 RELAY |
| D. OUT. 2 | TRIP | Q2 RELAY |
| D. OUT. 3 | D.O. 3 | Q3 RELAY |
| D. OUT. 4 | D.O. 4 | Q4 RELAY |
| D. OUT. EB1 | AUX 1 | Q1 EBLOCK |
| D. OUT. EB2 | AUX 2 | Q2 EBLOCK |
| D. OUT. EB3 | AUX 3 | Q3 EBLOCK |
| D. OUT. EB4 | AUX 4 | Q4 EBLOCK |
| D. OUT. EB5 | AUX 5 | Q5 EBLOCK |
| D. OUT. EB6 | AUX 6 | Q6 EBLOCK |
| D. OUT. EB7 | AUX 7 | Q7 EBLOCK |
| D. OUT. EB8 | AUX 8 | Q8 EBLOCK |

| Digital Inputs | | |
|----------------|-----------|-----------|
| D. INP. 1 | EXT. F. 1 | I1 RELAY |
| D. INP. 2 | EXT. F. 2 | I2 RELAY |
| D. INP. 3 | MUTE | I3 RELAY |
| D. INP. 4 | RESET | I4 RELAY |
| D. INP. EB1 | AUX 1 | I1 EBLOCK |
| D. INP. EB2 | AUX 2 | I2 EBLOCK |
| D. INP. EB3 | AUX 3 | I3 EBLOCK |
| D. INP. EB4 | AUX 4 | I4 EBLOCK |
| D. INP. EB5 | AUX 5 | I5 EBLOCK |
| D. INP. EB6 | AUX 6 | I6 EBLOCK |
| D. INP. EB7 | AUX 7 | I7 EBLOCK |
| D. INP. EB8 | AUX 8 | I8 EBLOCK |



Detail of the RJ45 connector for communication with the relay (CAN)



EBLOCK 88R

V5CON INTERFACE CONNECTIONS

Port A (Power): Connection for the system's 24 VDC power supply. VPS6024 OR VPS 12024 power supplies.

Port F (Relay): Connection with RJ45 cable between the Interface and the Zyggot relay.

Port E (Raddia Receiver): Connection with cable and mini USB connector between the Interface and the Raddia receiver.

Port C (Rs485): RS485 serial connection between the relay and the user's DCS system.

Port D (Rs485): RS485 serial connection between the relay and the user's DCS system.



INTERFACE V5CON

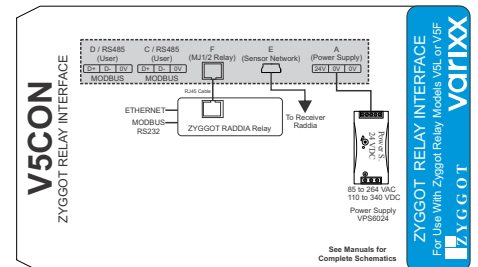
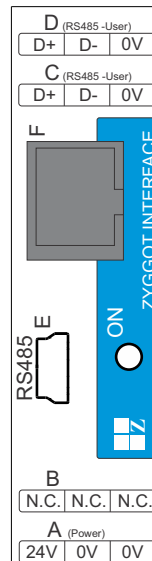

SINGLE-LINE DIAGRAM AND MAIN FEATURES

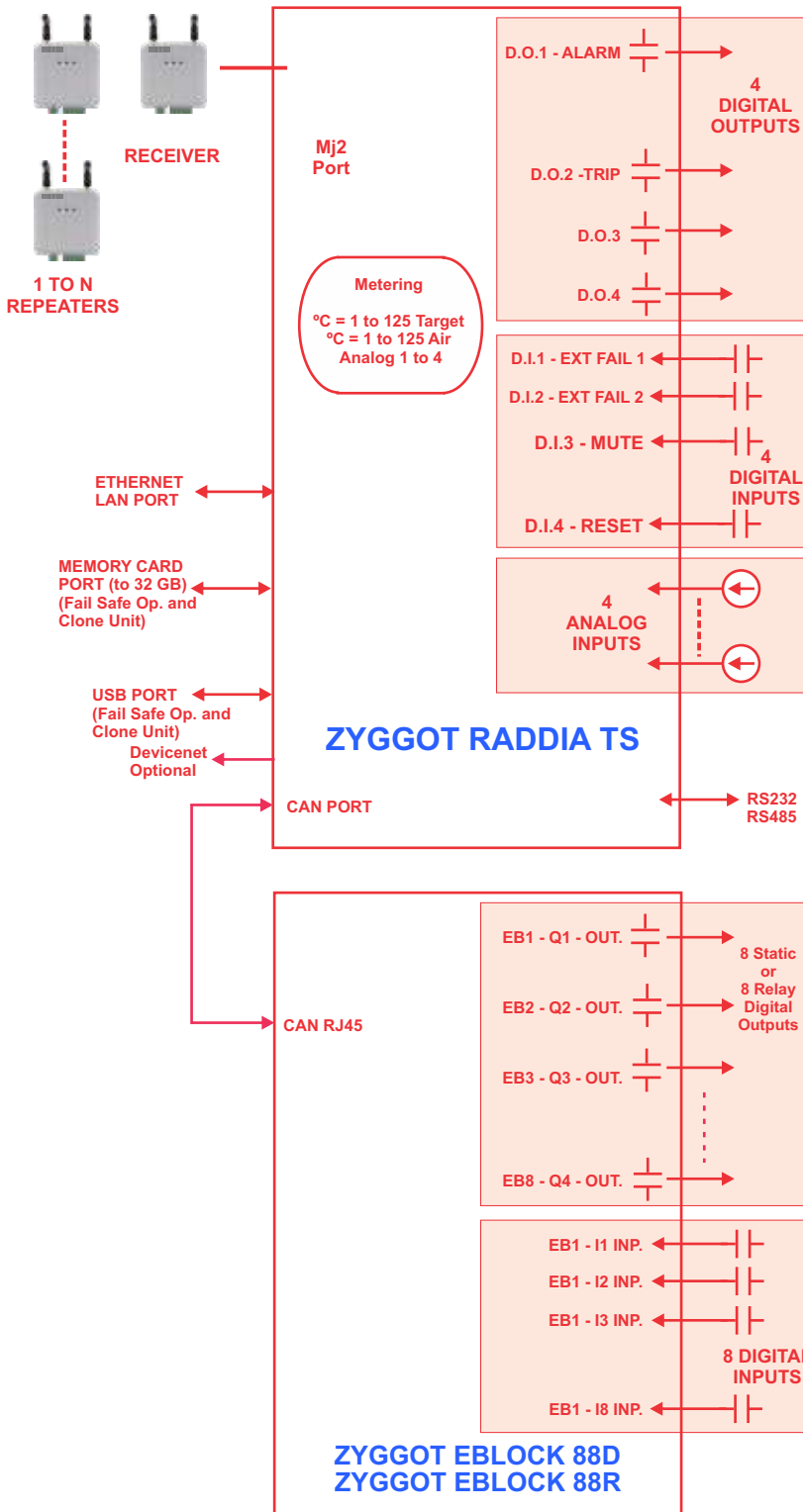

Measurement

The **Zyggot RADDIA TS** Relay provides accurate measurement of:

- * Up to 125 point temperatures.
- * 4 x 12-bit analog inputs for measurement and protection of external variables, such as other temperatures acquired by thermocouples and others.
- * Operating Hours.
- * Integrity of sensors in the network (Not Responding or OK)
- * Temperature of the Receiver

Display

Touch Screen graphic 64k colors display, with trend plot capability. The trend plot shows in real time in graphs of up to 4 sensors per screen the real behavior of any temperature or analog input.

Programming tools

A free program developed with graphical windows is provided free of charge by Varixx to further facilitate the parameterization of the relay. Even without this program, it is very easy to parameterize the relay through the HMI, with interactive and user-friendly menus. Another program tests and parameters each sensor (emissivity and address).

Event memory

The relays allow the memorization and indication of the last 120 faults with the date and time of occurrence. These indications are not lost even if the relay is switched off.

Communication ports

The ZYGGOT Raddia relay has 1 programmable RS232 or RS485 communication port with converter, which can be used for communication with supervisory systems or PLCs with Modbus RTU communication protocol. Another CAN port with CsCAN or Devicenet protocol (optional) allows communication and expansion.

There is a USB port and a port for Memory Card up to 32 GB.

An ETHERNET LAN port is also available but is not currently used by the embedded software.

Analog Inputs

The Zyggot Raddia relay has 4 12-bit analog inputs that can be used for measurement and protection, connected to external temperature transducers and others.

Digital Inputs

Zyggot Raddia relays have 4 configurable digital inputs, which can for example be connected to panel door micro switches or ventilation air flow sensors.

Digital outputs

There are 4 digital static outputs available on the relay and 8 digital static outputs (model Eblock 88D) or 8 relay outputs (dry contact) (model Eblock 88R), all configurable for alarm or trip, to indicate any of the faults.

Topology

Tubular Raddia TS allow quick and easy installation and parameterization.

TYPICAL CONNECTIONS

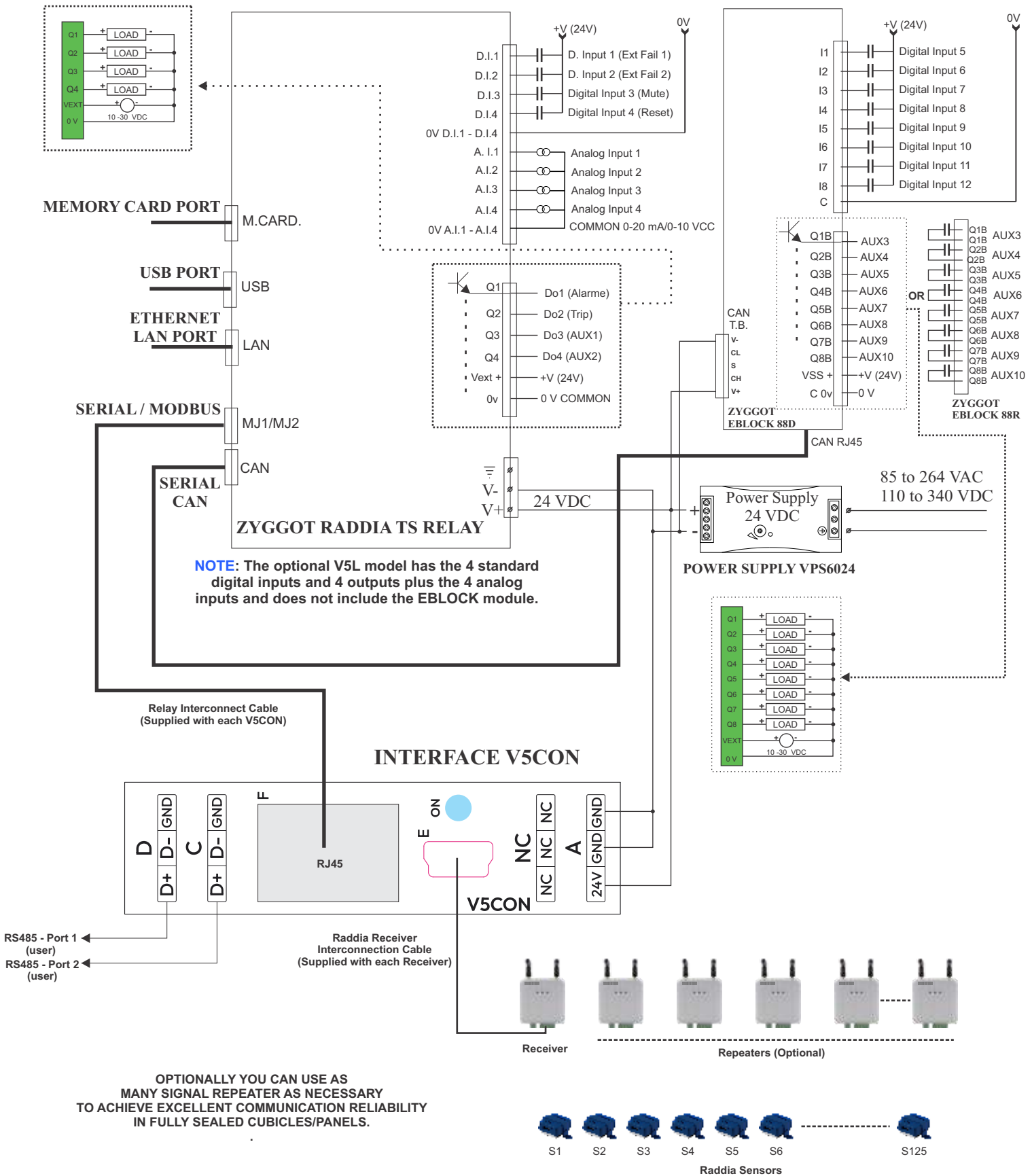

CONNECTIONS

Example of Using External Fault Connection with Zyggot UV Arc Flash Relay Varixx

ZYGGOT RADDIA TS THERMOGRAPHY



ZYGGOT ARC FLASH RELAY



One or two Zyggot Arc Flash relays for protection against Arc Flash by Ultra-violet detection connected to the external Fault input 1 and/or 2 for Real Time History purposes. Each Zyggot Arc Relay can monitor up to 50 sensors and as one sensor is normally used per cubicle, up to 50 cubicles can be protected per Zyggot Arc relay.

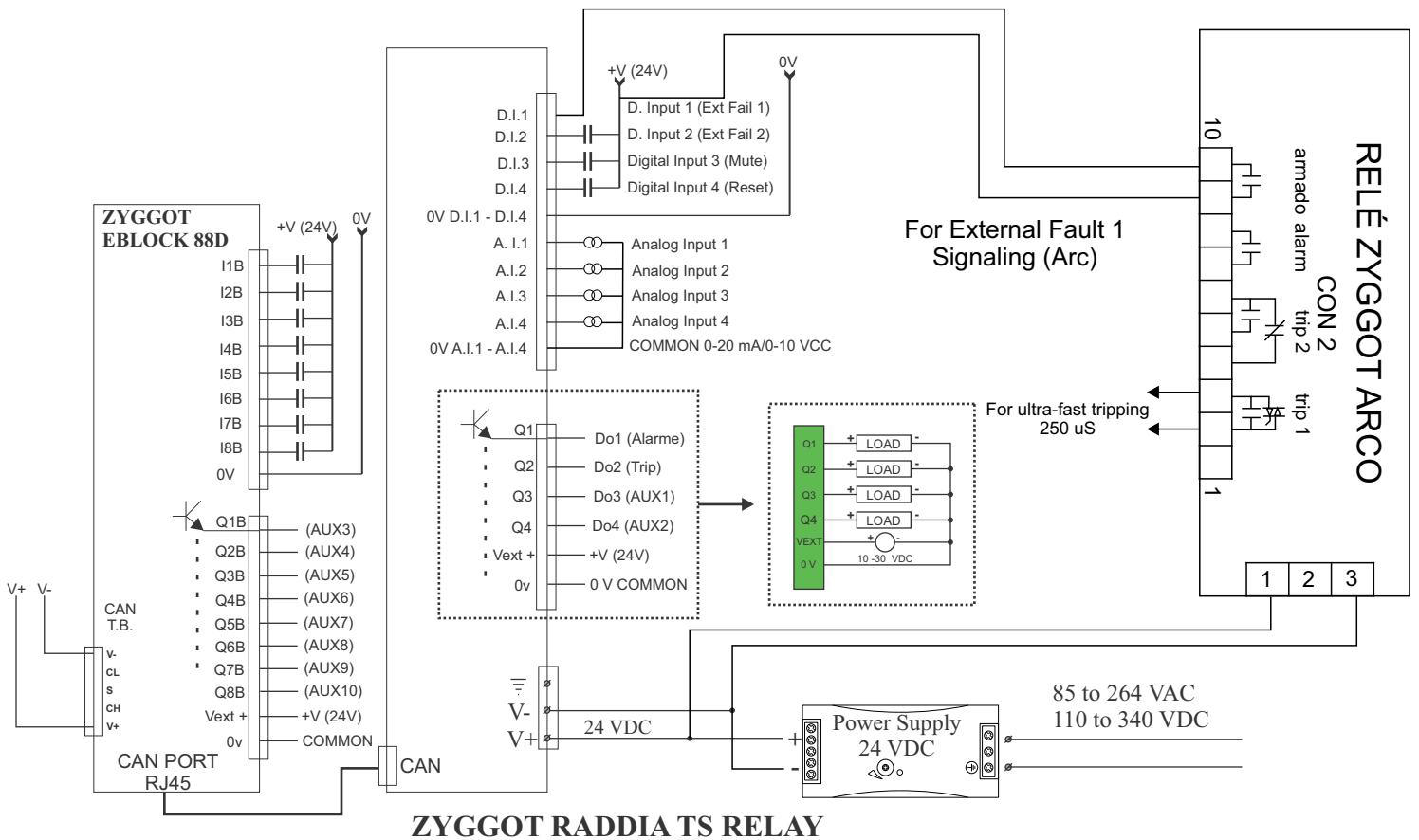

TYPICAL NETWORK AND INSTALLATION DETAILS OF THE RADDIA TS SENSOR

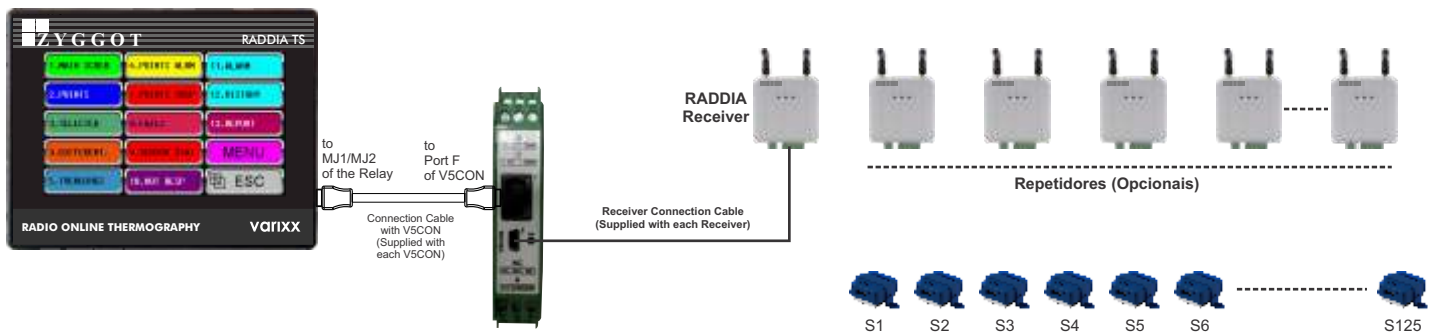

ASSEMBLY

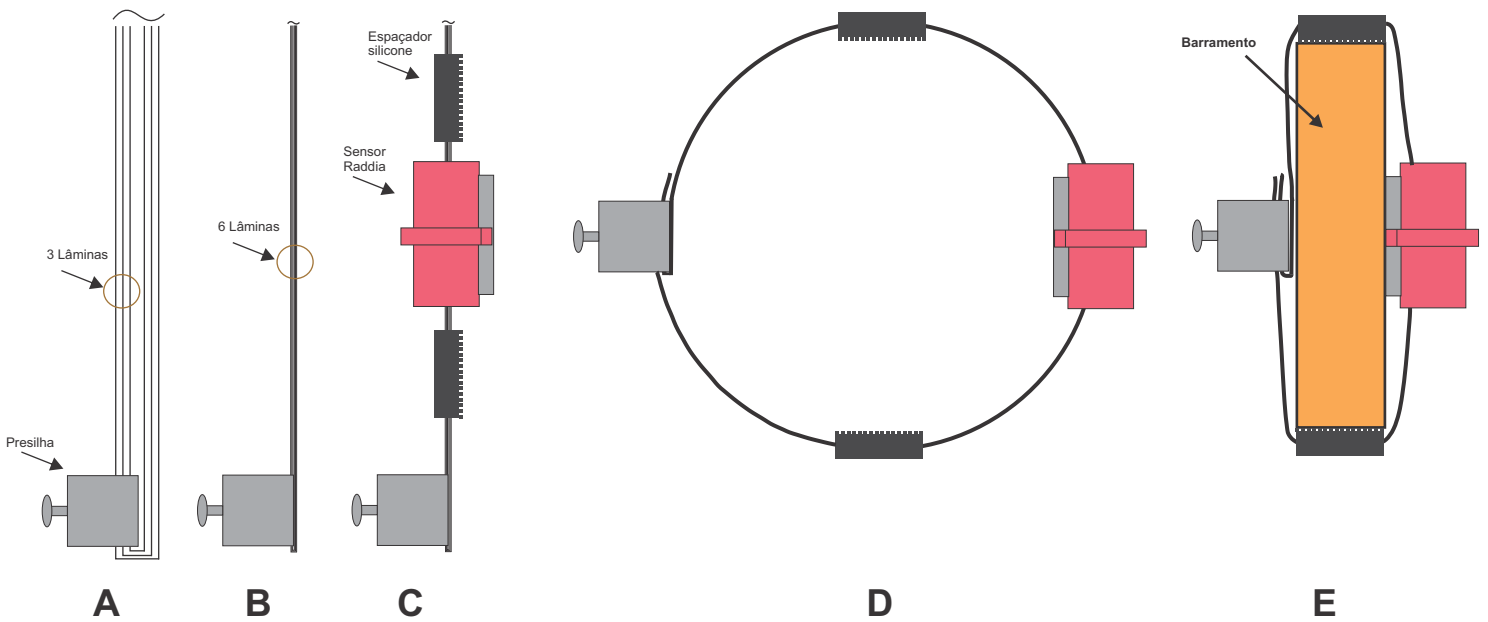

- A:** Pass the 3 strips through the clamp and fold them in half, ending with the ends at the same length.
 - B:** View of the folded strips and joined together, forming 6 layers.
 - C:** Pass the strips through the silicone spacers and Raddia TS sensor as shown.
 - D:** Pass the strips through the clamp again, wrapping around the rectangular or circular busbar.
 - E:** Fix the Raddia sensor to the busbar with the two screws of the polycarbonate support, adjust the metal strips and tighten the screw of the fastener. Cut the excess strip if necessary.
- NOTE:** If the busbar is very large, do not fold the strips in half and pass only 3 strips through the sensor. This will allow use on busbars twice the size, but the minimum current will also double from 3A DC to 6A DC.

MECHANICS



- 1- POWER 24 VDC
- 2- D.I. / A.I. CONNECTOR
- 3- D.O. / A.QO. CONNECTOR
- 4- CAN PORT
- 5- RS232/RS485 SERIAL PORTS
- 6- CONFIGURATION SWITCHES
- 7- ETHERNET LAN PORT
- 8- MICRO SD SLOT
- 9- USB PORT

PANEL CUTOUT

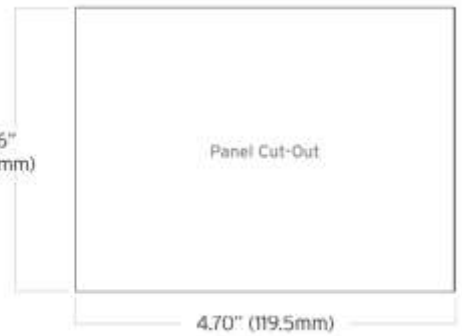

EBLOCK 88R

- 1- DIGITAL DC OUTPUTS
- 2- NETWORK ID SELECTOR SWITCHES
- 3- STATUS LEDs
- 4- DIGITAL DC INPUTS
- 5- CAN and POWER
- 6- EARTH GROUND
- 7- CAN PORT - RJ45

EBLOCK 88D or EBLOCK 88R

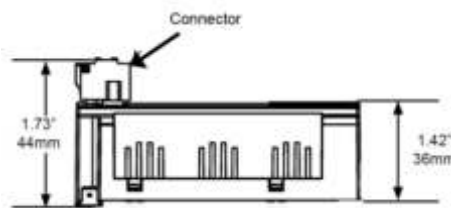
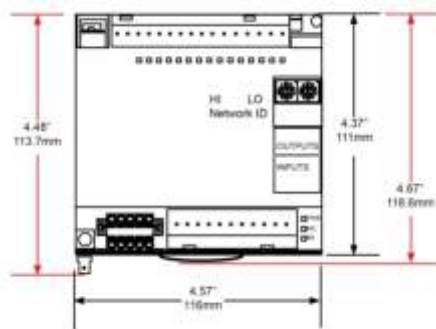

CAN Address Keys in Eblock 88x from 1 to 253 (decimal) or 01 to FD (Hexadecimal)



| DIP SWITCHES | | | |
|--------------|--------------------|-----------------|---------|
| PIN | NAME | FUNCTION | DEFAULT |
| 1 | RS-485 Termination | ON = Terminated | OFF |
| 2 | CAN Termination | ON = Terminated | OFF |
| 3 | Bootload | Always Off | OFF |

DIP Switches on Relay

RADDIA RELAY FEATURES + EBLOCK 88x

| | |
|---------------------------|--|
| Power Supply | 24 Vdc, 150 mA |
| Humidity | 5 to 95% |
| Relay Dimensions | 96 mm x 125 mm x 31 mm |
| Eblock Dimens. | 116 mm x 118,6 mm x 44 mm |
| Relay Ports | 1 x RS232 1 x RS485 1 x CAN (125 Kbps - 1 Mbps) 1 x Ethernet (1-10 Mbps/100 Mbps) 1 x USB Mini Program 1 x USB Flash 1 x Micro SD/SDHC |
| Inputs Relay + Eblock | 4 x analog 0-20 mA (50 ohms) 12 Bits, Error: 1,5% FS Max 4 + 8 digital Programmable - 0-24 VDC Min On= 8VDC. Max Off: 3VDC |
| Outputs Relay + Eblock | 4 + 8 (10 Programmable), Half-Bridge 0,5A max, 10 to 30 VDC, C. Source + (Protections: Short and Overvoltage) or 8 relay 3A @ 250VAC Resistive Load |
| Communication Relay | Modbus RTU, CAN Ethernet, Devicenet (Optional) |
| Communication Eblock | CAN |
| Relay Screen | Color, WVGA (480 x 272) Colors 64K Touch Screen (Resistive) 4,3" 450 cd/m² |
| Certificates | CE / FCC Compliance - Part 15 of FCC |
| Connectors | 3,5 mm - Pluggables |
| Weights | Relay: 270 g /// Eblock: 340 g |
| Temperature | Operation: -10 °C to 60 °C Stored: -30 °C to 70 °C |
| Battery RTC Relay | Operation: > 10 Years Stored: 5 to 10 Years Clock Error: 8 s / month at 25 °C max |

RADDIA RELAY:

- Operating Ambient Temperature: 0 to 45°C.
- Storage Ambient Temperature: -40 to 85°C.
- Relative Humidity: 5 to 95% N. C.
- NEMA Rating: NEMA 4X.
- Relay Weight: 270 Grams.
- Dimensions: 125 x 96 x 31 mm.
- Noise Immunity (EMC Immunity): EN61000-4-2 / EN61000-4-4 / EN61000-4-5 / EN61000-4-12 / ENV50140/50141
- Emissions: EN50081-2 / EN55022 / CISPR11. Class A.

CAN NETWORK:

- 1: V+
- 2: CAN H
- 3: SHIELD
- 4: CAN L
- 5: V-

CAN POWER RANGE:

12 to 25 VDC / 75 mA MAXIMUM.

SETTING UP AND TESTING SENSORS

A free sensor configuration program, once installed on a PC, allows each sensor to be correctly configured before installing them on the panels or even after they have been installed. The sensor can be reconfigured at will. More details can be found in the "Sensor Configuration" chapter later in this manual.

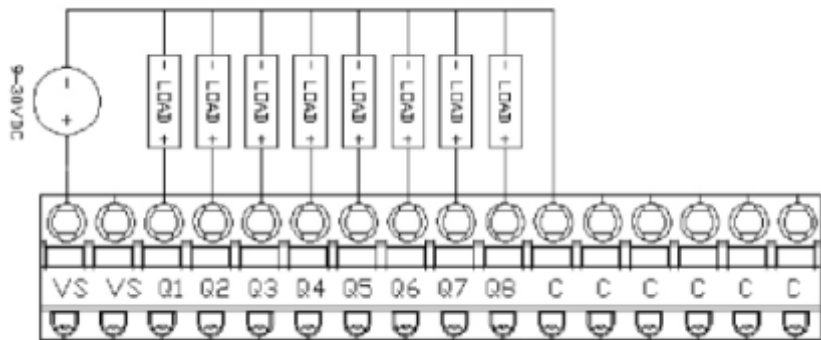

EBLOCK EB/88D OUTPUTS

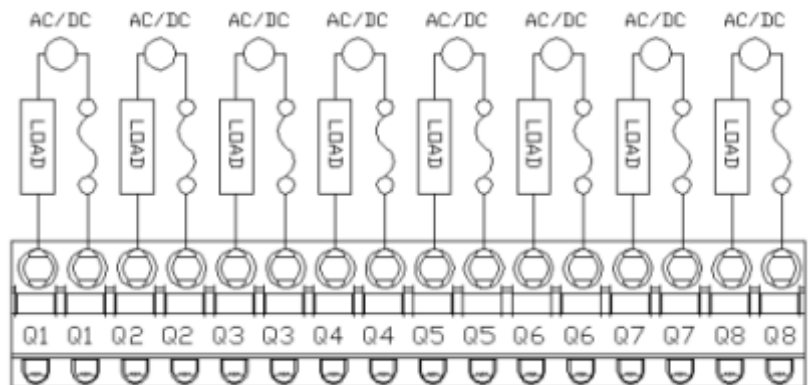

EBLOCK EB/88R OUTPUTS

RELAY TECHNICAL SPECIFICATIONS

POWER SUPPLY

| Signal Pin | Description |
|------------|----------------------------|
| V+ | Input power supply voltage |
| V- | Input power supply ground |
| Gnd | Frame Ground |

GENERAL CHARACTERISTICS

- ! Graphical LCD Touch Screen w/ Backlight.
- ! 24 VDC
- ! RS-232 / RS-485 Serial Ports.
- ! Integrated Bezel.
- ! Real-Time Clock.
- ! Flash Memory for easy field upgrades.
- ! Ethernet LAN Port.
- ! USB port e Memory Card (to 32GB) available.

CAN or CsCAN (OPT)

Peer-to-peer network. CAN-based network hardware is used in the controllers because of CAN's automatic error detection, ease of configuration, low-cost of design and implementation and ability to operate in harsh environments. Networking abilities are built-in to the control Module and require no external or additional modules.

CAN Network Baudrate vs. Total Cable Length

| Network Data Rate Maximum | Total Cable Length |
|---------------------------|--------------------|
| 1Mbit / sec. | 40m (131 feet) |
| 500Kbit / sec. | 100m (328 feet) |
| 250Kbit / sec. | 200m (656 feet) |
| 125Kbit / sec. | 500m (1,640 feet) |

Mj1/ MJ2 PORT MODULAR JACK

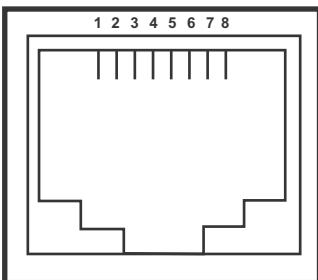

MJ 1 PORT

| PIN | SIGNAL |
|-----|--------|
| 1 | - |
| 2 | - |
| 3 | CTS |
| 4 | RTS |
| 5 | +5 V |
| 6 | 0 V |
| 7 | RXD |
| 8 | TXD |

Output Power Supply Max 150 mA

Features

| | |
|-----------------------------------|---|
| Display Type (LCD Touch Screen): | 64K Color Touch Screen |
| Display Size: | 4,3" |
| Display Screen: | 480 x 272 pixels |
| Touch Screen Type: | Resistive |
| Number of Colors: | 64K |
| Power Current: | 150mA @ 24VDC |
| Inrush Current: | (20A @ 24VDC) for 1ms. |
| Height: | 96.0 mm) |
| Width: | 125 mm) |
| Mounting Depth: | 31 mm) |
| Weight | 270 g) |
| Keypad Material: | Lexan HP92 by GE Plastics. |
| Protocols supported Serial Ports: | CsCAN, Modbus Master, Modbus Slave, and ASCII |
| Read and Write | |
| CAN Ports: | CsCAN (up to 253 drops) |
| Serial Ports: | 2: RS-232 / RS-485 Ports. |
| Network Ports: | 1: CAN (CsCAN peer) |
| Temperature & Humidity: | 10 - 60°C, |
| 5 to 95% Non-condensing | |
| CE | Compliant |

CAN PORT PINS

| PIN | SIGNAL | DESCRIPTION |
|-----|--------|-------------|
| 1 | V- | POWER - |
| 2 | CN_L | SIGNAL - |
| 3 | NC | NC |
| 4 | CN_H | SIGNAL + |
| 5 | V+ | POWER + |

Note: To optimize CAN network reliability in electrically noisy environments, the CAN power supply needs to be isolated (dedicated) from the primary power. The CAN Shield must be attached to the panel as close to the Relay as possible.

MJ 2 PORT

| PIN | SIGNAL |
|-----|---------|
| 1 | RX+/TX+ |
| 2 | RX-/TX- |
| 3 | - |
| 4 | - |
| 5 | +5 V |
| 6 | 0 V |
| 7 | - |
| 8 | - |

Output Power Supply Max 150 mA

MAIN SCREENS FOR OPERATION

MAIN MENU, (ESC) INFO SCREENS



MAIN MENU:

Screen from which all other system screens are accessed. From here, all operating and programming screens are accessed. Note that, to eventually draw the operator's attention, the «ALARM» field will flash and have a red border to indicate that there is an alarm that has not been viewed (Acknowledged) or Cleared (Cleared) on the alarm screen. By touching this field, you enter the alarm screen and can acknowledge and reset the alarm. More details below.

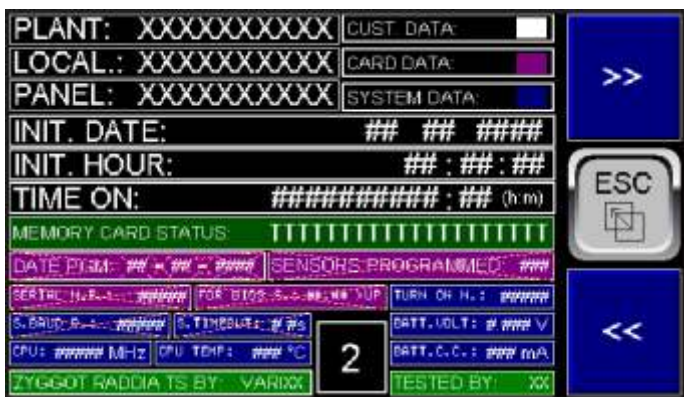

ATTENTION: THE ZYGGOT RADDIA TS RELAY LEAVES THE FACTORY WITH A PASSWORD TO ENTER THE PROGRAMMING MENU = «827499». CHANGE IT, WITHIN THE «RELAY CONFIG» MENU TO ANY OTHER VALUE (ADVISABLE).

INFO SCREENS 1 to 5:

There are 3 screens, scrolled by the >> and << keys and accessed by pressing the ESC key on the main menu.

INFO SCREEN 1: When the system is powered on, this is the initial screen. Pressing ESC takes you to the main menu above.

VERS: Software version

S.COMM OK: Indicates that the sensor network is communicating OK.

S.COMM ERROR: Indicates that the sensor network is communicating with an error.

DATE, TIME and DAY OF THE WEEK: Real time clock.

FAIL: Indicates a fault that has not been reset.

OT: Indicates a fault related to Over Temp of points.

RCV: Indicates a fault related to the receiver temperature.

NR: Indicates the existence of 1 or more sensors not responding on the network.

ALRM: Indicates an alarm condition that is not silenced (without Mute) and an active alarm output.

TRIP: Indicates a fault condition in Trip (active Trip output)

MAIN SCREENS FOR OPERATION

MAIN MENU, (ESC) INFO SCREENS

INFO SCREEN 2: It shows information about the plant, location and panel names, date and time of start of operation, total system operation time, relay serial number, software serial number, number of times the relay was turned on, baud rate and timeout of the sensor communication network, number of programmed sensors and finally it also shows some hardware information. Other fields as on screen 1.

INFO SCREEN 3: Mute Alarm and Reset Fail buttons.

When the alarm is active, the Mute button silences it (turns off the Alarm Output).

When the Mute condition is active (Mute has already been executed), the Reset button clears the fault and turns off the Trip Output.

Other fields as on screen 1.

Fail Active: Indicates that there is an active fault.

Alarm Unacknowledged: Indicates that there is an alarm that has not yet been acknowledged by the operator on the alarm screen and depending on what is programmed in the Reset on Fail Unacknowledge parameter, it will not be possible to reset the faults and cancel the trip output.

Alarm Uncleared: Indicates that there is an alarm that has not yet been cleared by the operator on the alarm screen and, depending on what is programmed in the Reset on fail Active parameter, it will not be possible to reset the faults and cancel the trip output.

INFO SCREEN 4: Information about the «Fail Safe» system, such as Auload Enabled, Autorun Enabled, Flash Backup Done (these 3 fields must be active, in green, for the «Fail Safe» system to operate correctly if necessary). Flash Backup Cleared: Indicates in yellow if there is no Backup file in the Flash memory. To create the backup file, enter the programming menu and create it after all the parameters have been programmed and the relay is operating correctly.

Auto Restore Done: Indicates whether there was an automatic software restoration and Autoload Fail indicates whether there was a restoration failure.

INFO SCREEN 5:

On this screen, you can control the write and read protection on the memory card for safe removal and insertion of the card, with the relay in operation, preventing it from being manipulated during writing operations that could corrupt it.

Remove/Insert: This button is invisible if the relay is in writing or reading operation so that the Remove/Insert command is not entered at an inappropriate time.

Wait: If active, it indicates that the relay is in writing or reading operation.

No Card: It is active if the relay does not have a memory card inserted.

Card OK: Indicates that the card is inserted and operating properly.

Ready to Remove/Insert: After the Remove/Insert command is selected in the «Yes» option, this indication becomes active, indicating that the card can now be removed or inserted.

Memory Card Status: May display one of the following messages depending on the current system condition:

- 1- Card OK - Operational**
- 2- Unknow Format**
- 3- No card in slot**
- 4- Card Not Supported**
- 5- Illegal Swapped**
- 6- Unknow Error**
- 7- Access Protected**

After the Insert/Remove command is set to «Yes», the message will be 6- Access Protected.

Attention: Removing the card without the Insert/Remove command inserts the Alarm condition in the alarm and history screen if the action for this failure is selected as «Log» in the programming menu. If the action is selected as «None», this alarm will not be logged.

If the card is removed after the Insert/Remove command, the alarm will not be triggered even if programmed for «Log»

MAIN SCREENS FOR OPERATION

MAIN SCREEN

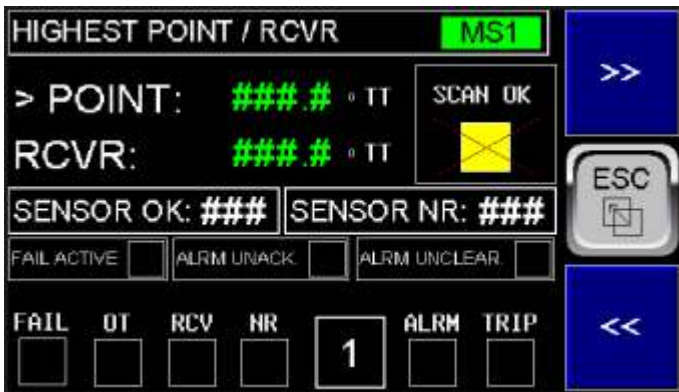

MAIN SCREEN MS1 to Ms12:

MS1:

> POINT: Shows the highest point temperature measured among all sensors.

RCV: Shows the ambient temperature measured by the Receiver.

SENSOR OK: Shows the number of sensors responding and in OK status in the network (Must be equal to the number of sensors in the network).

SENSOR NR: Shows the number of sensors not responding in the network (Must always be zero).

FAIL: Indicates Active Fault.

OT: Indicates overtemperature in any of the points.

RCV: Indicates ambient overtemperature measured by the Receiver.

NR: Indicates failure due to any number of sensors not responding.

ALRM: Indicates active ALARM output (without Mute).

TRIP: Indicates active TRIP output, without Reset.

Fail Active: Indicates that there is an active fault.

Alarm Unacknowledged and **Alarm Uncleared:** Indicate that there is an alarm acknowledged (Ack) and not cleared (cleared) respectively, still by the operator on the alarm screen and depending on what is programmed in the Reset on Fail Unack or Reset on fail Active parameters, it will not be possible to reset the faults and cancel the trip output.

SCAN. OK: It remains active in green if all sensors are OK and responding correctly.

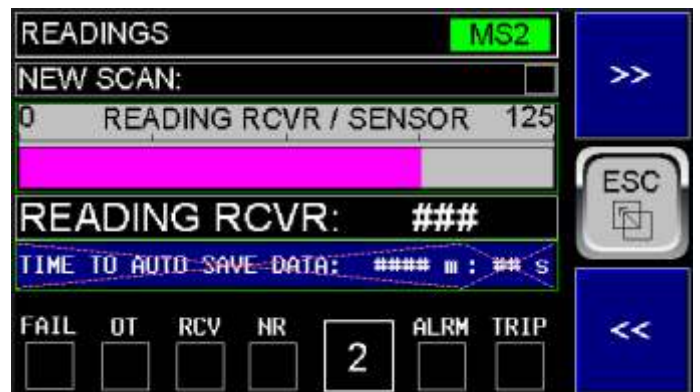

MS2:

NEW SCAN: Indicates new sensor reading scans on the network. This is done continuously.

READING SENSOR: Shows the number of the sensor being read and a bar graph corresponding to the number of the sensor currently being read. It serves to show activity and generate confidence that the sensors are being read continuously. It also shows the time remaining for new saving of the target and air temperature data of all sensors if programmed to perform this action. If not programmed, it will always show zero.

Other fields as in MS1.

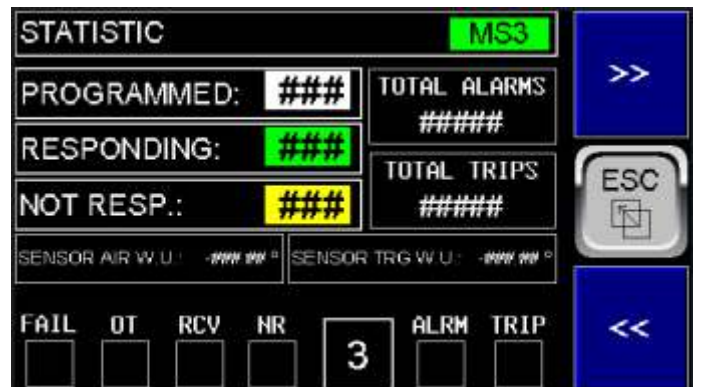

MS3:

PROGRAMMED: Shows the total number of sensors in the network.

RESPONDING: Shows the number of responding sensors in the network.

NOT RESPONDING: Shows the number of non-responding sensors in the network.

TOTAL ALARMS: Shows the total number of alarms that have occurred since the last reset of this number from the programming menu.

TOTAL TRIPS: Same as for number of trips that have occurred.

Other fields as in MS1.

MAIN SCREENS FOR OPERATION

MAIN SCREEN



4:
DIGITAL INP.1 to 4 & Digital Input EB1 (Aux 1) to EB8 (Aux 8):
 Indicates the states of digital inputs.
DIGITAL OUT 1 a 4 & Digital Output EB1 (Aux 1) a EB8 (Aux 8):
 Indicates the status of digital outputs.
Other fields as in MS1.

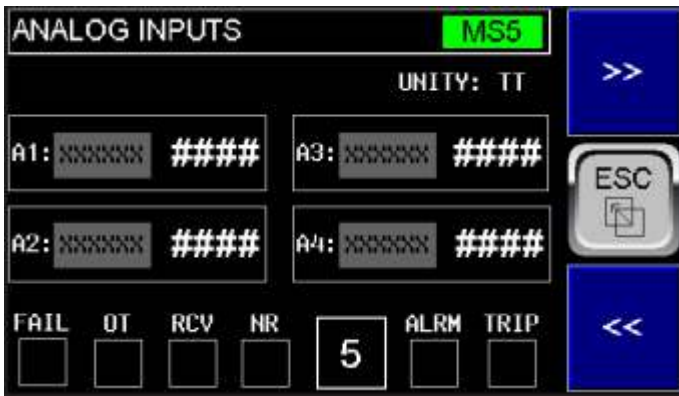

MS5:
ANALOG INP.1 a 4: Shows the values of Analog inputs 1 to 4 if used.
 It also shows the name assigned to each input to facilitate identification.
Other fields as in MS1.



MS6: Related to communication with sensors.
S. COMM OK: Indicates whether the communication is OK, without error.
S. COMM ERROR: Communication error with the sensor network.
TIMEOUT: Timeout error with the sensors.
FRAME/PARITY: Frame or Parity error on the network.
RESP FORM: Error due to an unexpected response.
Other fields as in MS1.

CRC/CHECKSUM: CRC (Cyclic Redundance Check or Checksum) error.
REJECT ADDR: Indicates whether the address was rejected.
Other fields as in MS1.



MS7: Related to Modbus communication
MODB ACTIV: Indicates whether MODBUS is active.
MODBUS INACTIVE: Indicates whether MODBUS is inactive.
MODBUS OK: Indicates whether Modbus is OK, without error.
MODBUS ERROR: Indicates whether there is an error in Modbus.
MODBUS STATUS: (STANDBY, TIMEOUT, VALID MESSAGE, PARITY ERROR, FRAME ERROR, OVERRUN ERROR, CHECKSUM ERROR, INACTIVE) Indicates the possible states.
Other fields as in MS1.

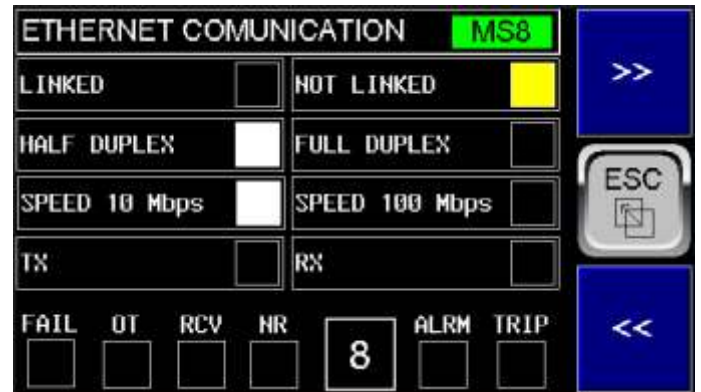

MS8: Related to ETHERNET communication
LINKED: Indicates that the Ethernet cable is connected.
NOT LINKED: Indicates that the Ethernet cable is disconnected.
HALF DUPLEX and FULL DUPLEX: Indicates the current communication mode.
SPEED 10 Mbps and SPEED 100 Mbps: Indicates the current communication speed.
RX: Indicates receiving data.
TX: Indicates transmitting data.
Other fields as in Ms1.

MAIN SCREENS FOR OPERATION

MAIN SCREEN



MS9:
POINT ALARM: Indicates if there is any target in alarm condition.
POINT TRIP: Indicates if there is any target in Trip condition.
RECEIVER ALARM: Indicates receiver temperature in alarm condition.
RECEIVER TRIP: Indicates receiver temperature in trip condition.
DIFFERENTIAL: Indicates if there is any point in alarm condition or trip due to differential.
S. COMM FAIL: Indicates if there is a communication error in the network.
NOT RESP: Indicates Not Responding failure.
MODBUS FAIL: Indicates failure related to Modbus communication
Other fields as in MS1.

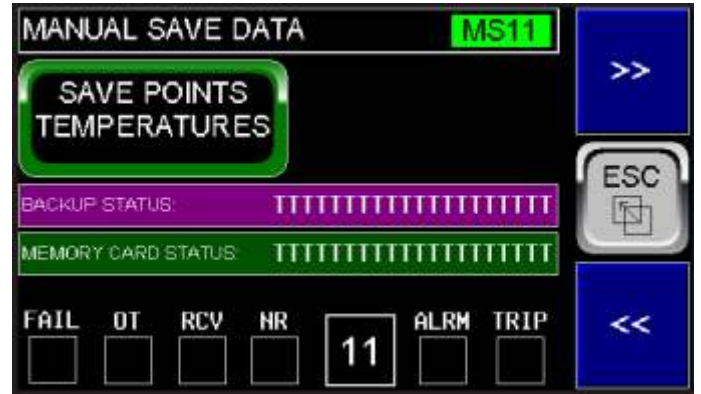

MS11:
 On this screen, you can save target and air temperature data from all sensors to the memory card, at any time, by manual command. These files are in Excel CSV format with data separated by commas and can be opened in Excel and generated into tables or graphs.
SAVE POINT TEMPERATURES: When pressed, the background will be green while the target temperature data is added to the corresponding file on the memory card. This file is located in the **DATAMAN** directory and in the **POINTTDATA** file and the data is added to the existing ones with the following sequence: **dd, mm, yyyy, hh, mm, ss, 0, NS, SR, 0, T1, T2, T3,.....Tn.** (zero is used as a separator).
MEMORY CARD STATUS: shows one of the sentences, as described in Info Screen 4 above.
BACKUP STATUS: Displays one of the following sentences depending on the current situation:
1- STANDBY / 2- OK - PROCEED / 3- ERROR - CHECK CARD / 4- DONT BACKUP ON FAIL / 5- OK - DONE / 6- WRITING / 7- READING / 8- BUSY.

Example below, point temperatures, with 3 sensors and 2 responding.



MS10:
MUTE ALARM / RESET FAIL: Buttons that allow you to silence (Mute Alarm) the alarm or reset (Reset Fail) the fault condition. Reset Fail will only act if it is already silenced (Mute) and if 'Reset on Fail' is programmed if there is still an existing fault.
Other fields as in MS1.

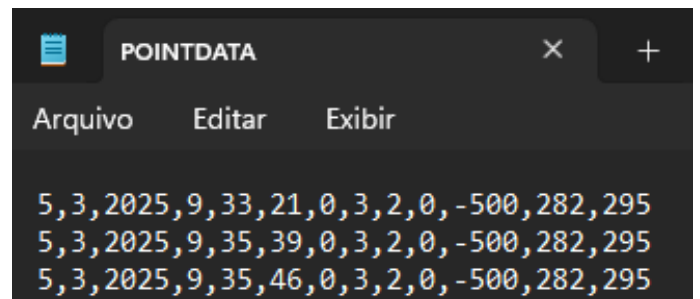
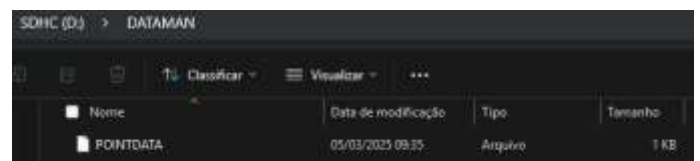

MAIN SCREENS FOR OPERATION

POINT, SELECT POINT

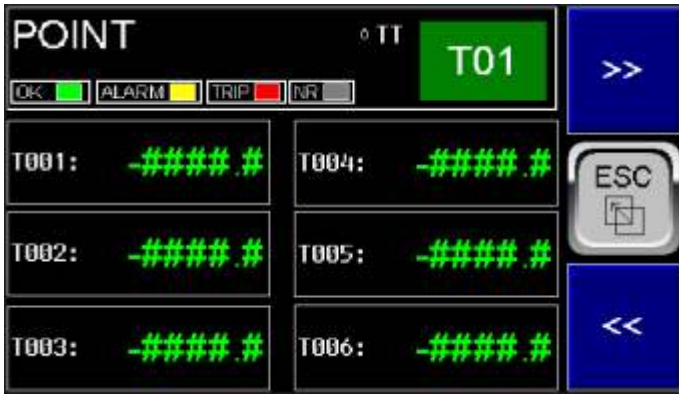

TARGET T01 to T21:

There are 21 screens, scrolled by the >> and << keys.

T01 to T21: Screen Index. Flashes if any of the Target values is above the set alarm value.

°TT: Indicates °C (degrees Centigrade) or °F (degrees Fahrenheit), as programmed.

T001 to T125 (screens 1 to 21): Shows the current temperature of each target. The color will be white if within the normal range, yellow if above the programmed Alarm point and red if above the programmed Trip point. If yellow or red, it will also flash.

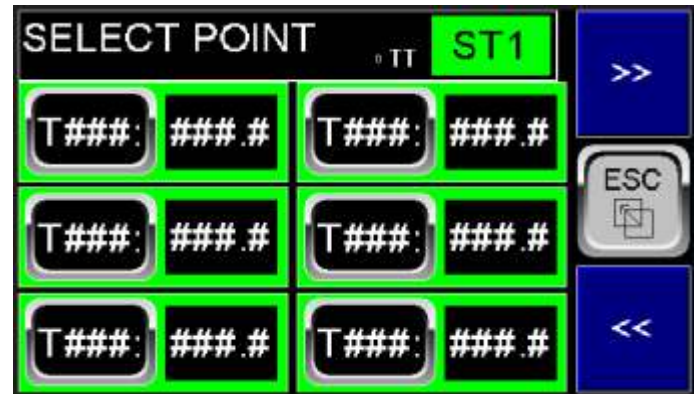

SELECT TARGET ST01 to ST4:

There are 4 screens, scrolled by the >> and << keys.

ST01 to ST4: Screen Index. Flashes if any of the Target values, even if not selected, is above the stipulated alarm value.

T###: Sensor index, from 1 to 125, which the operator can enter by touching this key to monitor the Target Temperature. Flashes if this temperature is above the alarm level programmed for it.

###.#: Shows the current temperature of the selected target. The color will be white if within the normal range, yellow if above the programmed Alarm point and red if above the programmed Trip point. If yellow or red, it will also flash.

°TT: Indicates °C (degrees Centigrade) or °F (degrees Fahrenheit), as programmed.

MAIN SCREENS FOR OPERATION

FAILS

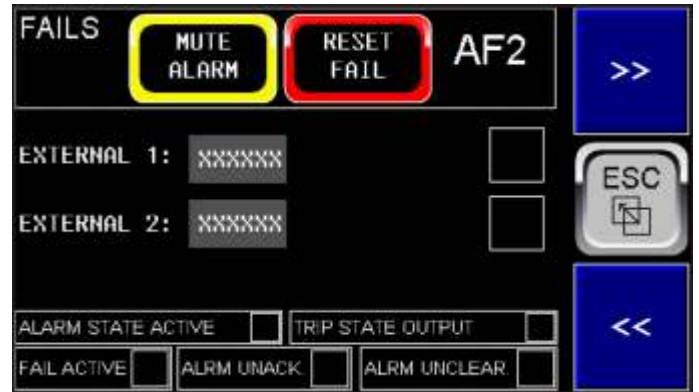

FAILS AF1 to AF7:

There are 7 screens, scrolled by the >> and << keys.

AF1 to AF7: Screen Index.

Indicates the currently active faults (Alarm and Trip) if selected in the programming menu. Screens 6 and 7 indicate faults in specific sensor groups as programmed for the respective groups in the menu.

The Mute Alarm and Reset Fail buttons on each screen allow you to silence the alarm (digital alarm output) or Reset the fault, respectively. Note that to reset the fault, you must first perform the Mute function and also that the fault no longer exists if the 'Reset On Fail' parameter is not enabled in the Programming menu.

They also show the conditions: **Alarm State Active** and **Trip State Output**.

Fail Active, Alarm Unacknowledged and **Alarm Uncleared**: as detailed in screen MS1

MAIN SCREENS FOR OPERATION

TRENDINGS

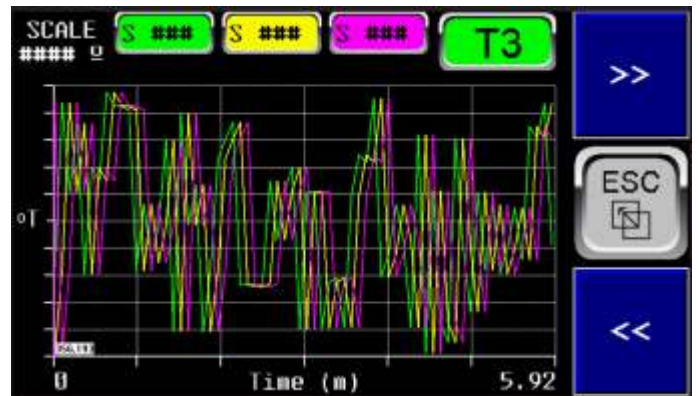
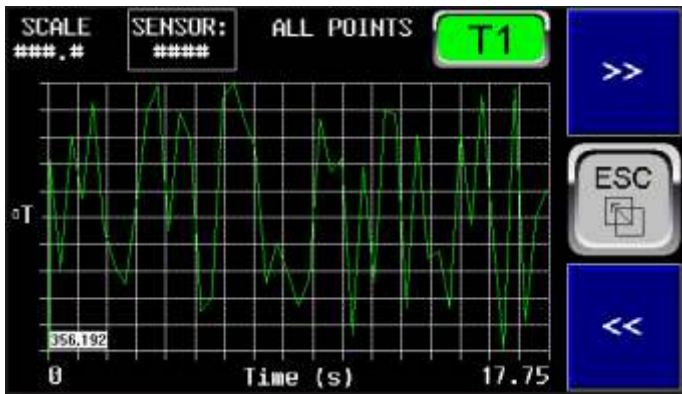

TRENDING PLOT T1 and T2 (Continuous Scope):

There are 18 screens, scrolled by the >> and << keys. These are the first two.

T1 and T2: Screen Index and curve reset button (Plot restart) if programmed to be active in the programming menu.

The first two show all the Target and Air temperatures respectively, of the sensors programmed in the network. With each 'scan' of all the temperatures, the curve goes down to zero and repeats this continuously as if it were an electrocardiogram. The 'scan' never stops and the curve is continually shifted to the left.

The sampling time is **50 mS** and each screen can show **17.75 seconds**. When leaving this screen and returning to it, the curves restart, unlike the curves from **T4 to T18**.



TRENDING PLOT T3 (Continuous Scope):

This is the third screen of the 18 plot screens, scrolled by the >> and << keys.

T3: Screen Index and curve reset button (Plot restart) if programmed to be active in the programming menu.

On this screen, you can enter the indexes of 3 sensors, from 1 to 125, and if you enter «0» (Zero), the trace remains at zero. With each 'scan', the curve goes down to zero and repeats this continuously as if it were an electrocardiogram. The «scan» never stops and the curve is continually shifted to the left.

The sampling time is **1000 mS**, and each screen can show **5.92 minutes** in total. When you leave this screen and return to it, the curves restart, unlike the curves from **T4 to T18**.

When you press the T3 key, the button appears in red, asking if you are sure you want to restart the curves on this screen. If yes, the operator will have 10 seconds to enter the answer "Yes" on the button and touch T3 again. Otherwise, the red button disappears and the curves are not reset.

MAIN SCREENS FOR OPERATION

TRENDINGS

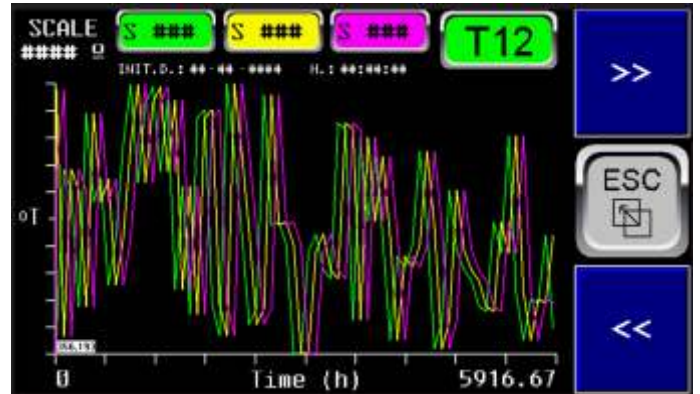
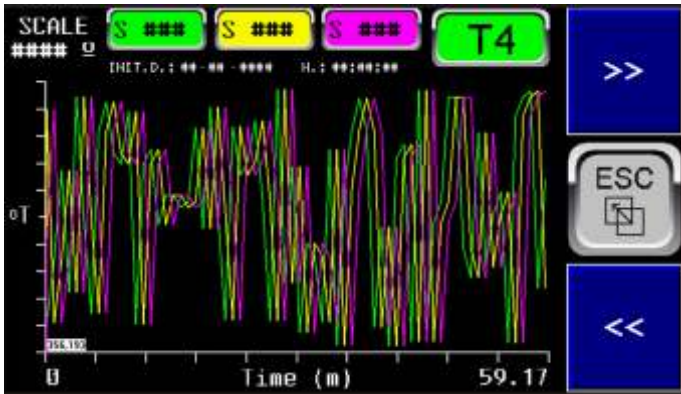

TRENDING PLOT T4 to T12 (Trending Plot):

These are screens 4 to 12 of the 18 screens paged by the >> and << keys.

T4 to T12: Screen Index and curve reset button (Plot restart) if programmed to be active in the programming menu. Screens T4 to T12 show 3 sensors each, selected on the screen itself using the S keys (or in the programming menu) and each screen has different reading time bases (See Table). These Screens do not restart the reading automatically when exiting them, they are functional even if they are not displayed and show the curves when you return for them. However, when the screen is finished, the plot does not remain inactive but always shows the memorized traces even if the relay is turned off and on again.

The date and time of the start of the plot is shown in the upper part of each screen independently of the others.

To restart, touch the buttons T4 to T12.

When pressing keys T4 to T12, a red button appears, asking if you are sure you want to reset the curves on this screen. If so, the operator will have 10 seconds to enter the answer "Yes" on the button and touch T4 to T12 again. Otherwise, the red button disappears and the curves are not reset.

If the red button is counting down from 10 seconds and you exit the screen, it will also be automatically extinguished.

| Screen | Sampling Time | Screen Cycle |
|--------|---------------|--------------|
| 1 & 2 | 50 ms | 17,75 s |
| 3 & 8 | 1000 ms | 5,92 m |
| 4 & 9 | 10 s | 59,17 m |
| 5 & 10 | 100 s | 591,67 m |
| 6 & 11 | 1000 s | 5916,67 m |
| 7 & 12 | 1000 m | 5916,67 h |
| 13 | 50 ms | 17,75 s |
| 14 | 1 s | 355 s |
| 15 | 10 s | 59,17 m |
| 16 | 100 m | 591,67 h |
| 17 | 1000 m | 5916,67 h |
| 18 | 10 s | 59,17 m |

MAIN SCREENS FOR OPERATION

TRENDINGS

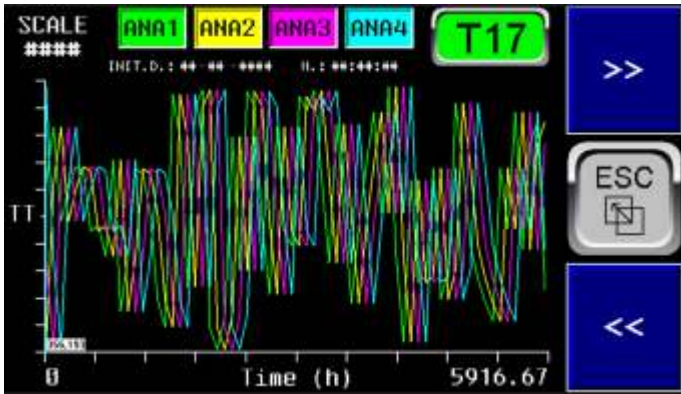

TRENDING PLOT T13 to T17 (Trending Plot):

These are screens 13 to 17 of the 18 screens paged by the >> and << keys.

T13 to T17: Screen Index and curve Reset button (Plot restart) if programmed to be active in the programming menu.

Screens T13 to T17 show 4 curves each, corresponding to the 4 analog inputs, with different sampling times (See Table). The X axis shows whether the scale is in temperature (°C or (°F) or percentage (%) and the scale value is shown in the upper left. These screens do not automatically restart the reading when exiting them, they are functional even if they are not displayed and show the curves when returning on them. However, when the screen is finished, the plot does not remain inactive but always shows the memorized lines even if the relay is turned off and on again.

The date and time of the start of the plot is shown in the upper part of each screen, independently of the others.

If the relay is turned off and on again, the previous sampling is not lost and the new sampling is separated by a vertical black line.

To restart, touch buttons T13 to T17.

When pressing keys T13 to T17, a red button appears, asking if you are sure you want to restart the curves on this screen. If so, the operator will have 10 seconds to enter the answer "Yes" in the button and touch T13 to T17 again. Otherwise, the red button disappears and the curves are not reset.

If the red button is counting down for 10 seconds and you leave the screen, it will automatically disappear as well.

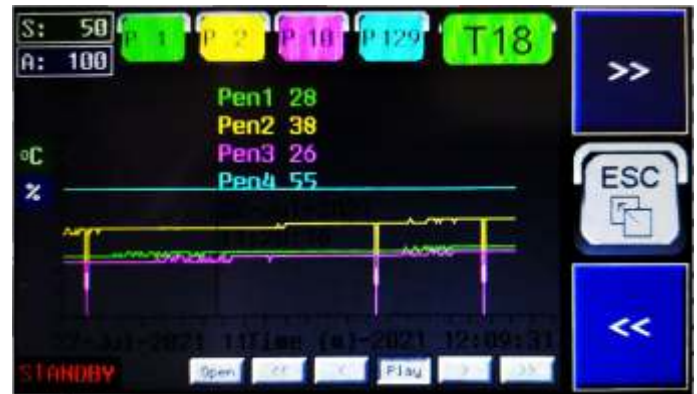

TRENDING PLOT T18 (Retentive Trending Plot):

This is screen 18 of the 18 screens that can be paged by the >> and << keys.

This feature allows the recording of the curves and data plotted on it on a memory card of up to 32 Gb inserted in the appropriate slot on the relay.

When initialized in the programming menu, the screen will display in the lower left corner the information in green letters "STARTED" and a file folder will be automatically created on the card with the name **Plotzxx** where xx is the end of the current node. If it is not started, the message will be "STANDBY".

When in "Started", a new file with the csv extension will be created every hour within this file, with the name consisting of the day, month and full hour, without the minutes. Each file contains data separated by commas, which can be opened in Excel using the "Get data" function in the "Data" tab and graphs can be generated. Each file is automatically saved hourly and will contain 360 readings of each of the 4 variables (4 traces). Each reading is taken every 10 seconds. These are light files of approximately 18 Kb each. Even if you exit the screen, the recordings continue and if the recording is interrupted by turning the power off and on again, a vertical black line appears at this point and the recording continues.

MAIN SCREENS FOR OPERATION

TRENDINGS

The top left corner shows the two scales, for target temperatures of the sensors in green and analog inputs in blue.

The vertical Y axis shows the two corresponding units, °C in green for the sensors and % or ° for the analog inputs, depending on what is programmed in the programming menu for them.

The screen index (**T18**) is in the top right corner. This button does not allow for resetting or restarting the curve and, if pressed, indicates with a sentence to enter the programming menu, turn this feature off and on again to restart the curves. This is done for safety reasons so that the memorization is not inadvertently lost.

The recorded curves can also be redrawn on the screen by the relay itself, for examination. While they are being re-displayed, the user can move his finger on the screen and move the cursor (a vertical black line) to display, for each point, the index of each line and the corresponding value, with the corresponding colors corresponding to the lines, in addition to the date and time of the recording.

At the bottom are the playback control keys, namely: «**Pause**» or «**Play**». If «**Pause**» is displayed, the operation is effectively in Play mode and the curves are being generated and plotted in real time. When pressed, it changes to «**Play**» and the operation is effectively in Pause mode and the curves displayed are previously recorded, obtained from the memory card. In other words, the button actually shows the state that will be entered when pressed.



«<<<» This button allows you to search for the first recorded curve in the file within the date and time range selected in the Open button.

«>>>» Same as above, this button allows you to search for the last recorded curve in the file.

«<» and «>» same as above, allow you to search one by one in the sequence for the recorded sequential curves.

«**Open**» button that allows you to select a time range for the curves to be retrieved, by date and time, by entering the start date and time and end date and time of the period of interest in the window that opens, to restrict the number of curves to be paged through using the search keys above and to make their location easier.

Below we see an example of the structure of Plot files on the card.

| Nome | Data de modificação | Tipo | Tamanho |
|------------|---------------------|--------------------|---------|
| 081809.CSV | 18/08/2021 09:55 | Arquivo de Valo... | 11 KB |
| 081213.CSV | 12/08/2021 13:57 | Arquivo de Valo... | 16 KB |
| 081212.CSV | 12/08/2021 12:59 | Arquivo de Valo... | 18 KB |
| 081211.CSV | 12/08/2021 11:59 | Arquivo de Valo... | 18 KB |
| 081210.CSV | 12/08/2021 10:59 | Arquivo de Valo... | 16 KB |
| 081209.CSV | 12/08/2021 09:50 | Arquivo de Valo... | 14 KB |

| | A |
|----|--|
| 1 | Date,Time,Pen1,Pen2,Pen3,Pen4 |
| 2 | 19-08-2021,10:00:03 AM,000052,000056,000000,000000 |
| 3 | 19-08-2021,10:00:13 AM,000052,000056,000000,000000 |
| 4 | 19-08-2021,10:00:23 AM,000052,000056,000000,000000 |
| 5 | 19-08-2021,10:00:33 AM,000052,000056,000000,000000 |
| 6 | 19-08-2021,10:00:43 AM,000052,000056,000000,000000 |
| 7 | 19-08-2021,10:00:53 AM,000052,000056,000000,000000 |
| 8 | 19-08-2021,10:01:03 AM,000052,000056,000000,000000 |
| 9 | 19-08-2021,10:01:13 AM,000052,000056,000000,000000 |
| 10 | 19-08-2021,10:01:23 AM,000052,000056,000000,000000 |
| 11 | 19-08-2021,10:01:33 AM,000052,000056,000000,000000 |

MAIN SCREENS FOR OPERATION

POINT ALARM, POINT TRIP, NOT RESPONDING, DIFFERENTIAL

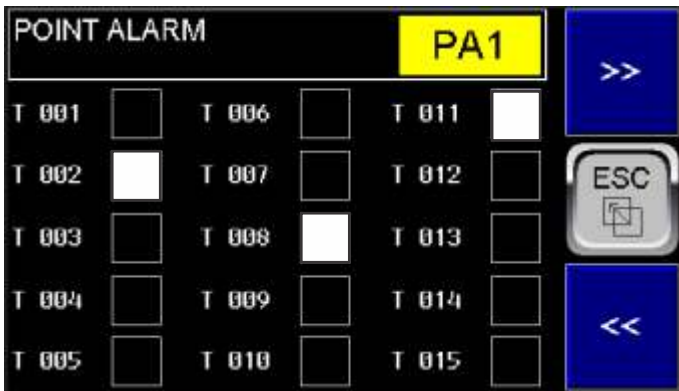

POINT ALARM TA1 to TA9:

There are 9 screens scrolled by the >> and << keys.
PA1 to PA9: Screen Index. Flashes if any of the Point values is above the value programmed for the alarm.
T001 to T125: Indicates whether the temperature of each Point is above the value programmed for the alarm.

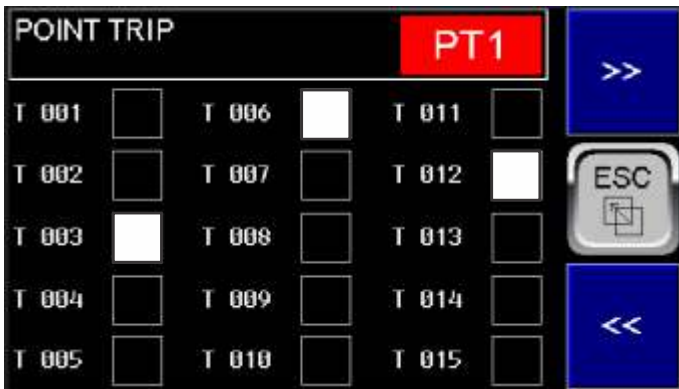

POINT TRIP PT1 to PT9:

There are 9 screens scrolled by the >> and << keys.
PT1 to PT9: Screen Index. Flashes if any of the Point values is above the value programmed for Trip.
T001 to T125: Indicates whether the temperature of each point is above the value programmed for Trip.

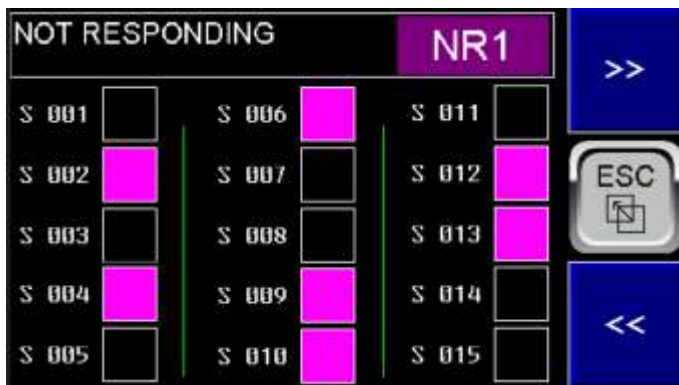

NOT RESPONDING NR1 to NR9:

There are 9 screens scrolled by the >> and << keys.
S001 to S125 (from screens NR1 to Nr9): Indicates whether the respective sensor has stopped responding to the relay on the network.

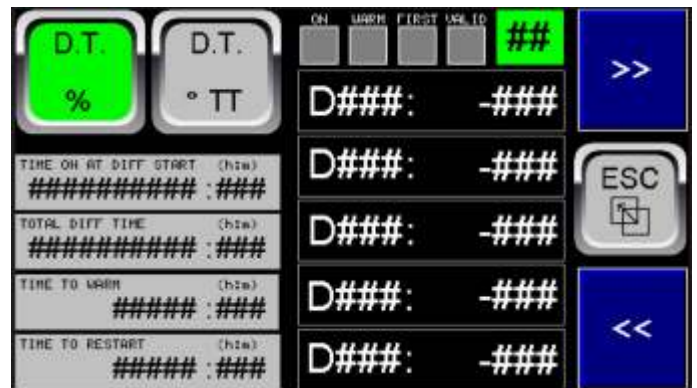

DIFFERENTIAL 1 to 21:

There are 21 screens that are paged by the >> and << keys. When activated, the sensor indexes are paged 5 by 5 from D1 to D125 and the other fields remain on the screen.

(1) to ## (9): Screen index.

DT%: Button that selects to show the values as a percentage of variation in the programmed time. When selected, it changes from gray to green.

TEMP (°TT): Button that selects the option to show the values as a differential of temperature variation in the programmed time. When selected, it changes from gray to green. °TT shows whether it is in Celsius or Fahrenheit.

ON: Indicator that the system has started the differential function (if programmed for this in the programming menu).

WARM: Indicates that the programmed heating period has passed, during which the system ignores the readings for calculating the differential variation, waiting for the system to stabilize in a normal operating temperature condition.

FIRST: Indicates that the first reading was performed, after the 'Warm' period, on which the differential variations will be calculated for each new reading

VALID: Indicates whether the new reading is valid for differential calculations.

TIME ON AT DIFF. START: Shows, for information purposes, the 'On' time in hours and minutes since the system was started, as per screen 2 of the information screens.

TOTAL DIFF. TIME: Shows the total time since the first valid reading was performed and on which the differential is calculated.

TIME TO WARM: Shows a retroactive counter to zero of the time remaining to complete the «Warm» period as programmed.

TIME TO RESTART: (only appears if set to «Valid») Shows a retroactive counter to zero of the time remaining in hours and minutes, for automatic restart of a new differential period, if programmed for this in the programming menu. If not programmed for automatic restart, the system remains indefinitely considering the first reading taken after Warm. If restarted, manually or automatically, and the system is already in stable condition (after Warm), a new Warm period is not expected and a new initial reading is performed for future differential calculations. Until the differential calculation begins, after Warm, this field is displayed as 0:0

D### to D###: Sensor indexes from 1 to 125 if the system is operating with an active and valid differential, otherwise D0 is displayed in all 5 fields.
###: Differential value in % or temperature (°C or °F) for each index from D1 to D125, according to the selection in the % or Temp. selection buttons described above. This value is white if it is below the differential value programmed for alarm or yellow if it is above the differential level programmed for Trip. In both cases it also flashes in addition to changing color.

MAIN SCREENS FOR OPERATION

ALARM, HISTORY

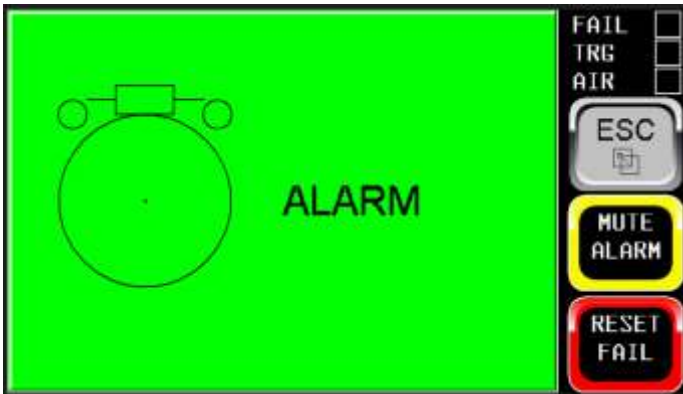

ALARM SCREEN:

ALARM: This is a screen where you can check all Alarms, Faults and events that have occurred, with date and time (Time Stamp), in addition to being able to acknowledge them (Acknowledge) or (ACK) or clear them (Clear). To do this, touch any point on the Alarm screen that is green in normal condition or red in condition of activated and unacknowledged faults (ACK) or cleared (CLR) or yellow if there are faults with ACK but not Clear.

Fail: Indicates on this screen that there is an active fault that has not been reset.

TRG: Indicates on this screen that there is a fault related to Target.

AIR: Indicates on this screen that there is a fault related to Air.

MUTE: Alarm mute button. Turns off the alarm output.

RESET: Fault reset button. Only works after Mute.



HISTORY SCREEN:

HISTORY: This is a screen where you can check all the events that have occurred, with date and time (Time Stamp), but you cannot acknowledge or clear them. There is another screen for this, accessed from within the programming menu. Tap anywhere on the History screen.

The events stored include the Ack and Clear actions performed on the Alarm Screen above, as well as the deactivation of the fault that occurred (Return).

The other fields are the same as those on the Alarm screen above.

MAIN SCREENS FOR OPERATION

REPORT

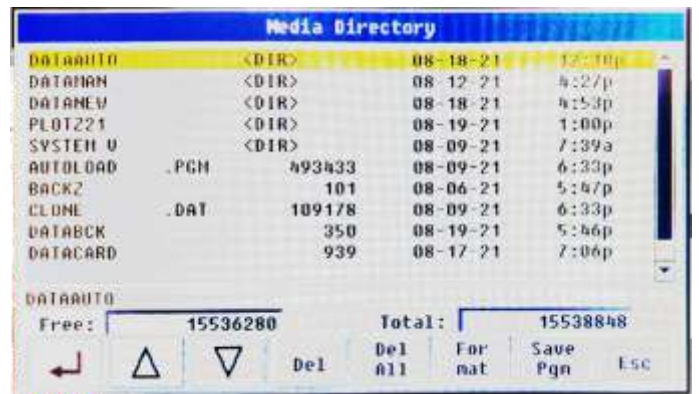
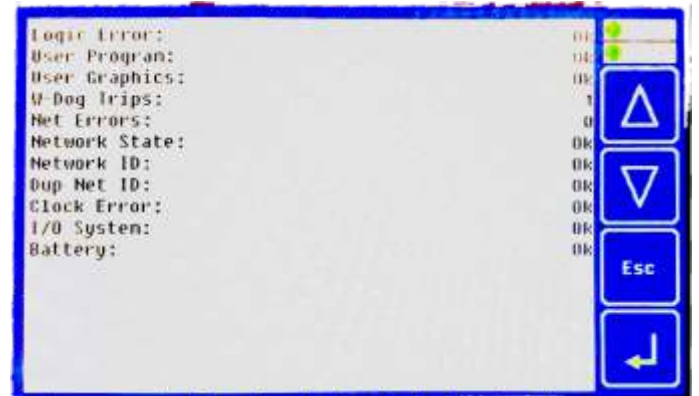

REPORT SCREEN 1 to 5:

There are 5 screens that reproduce the Programming Menu and two more system information screens, where you can check the various programming conditions without accidentally changing the programming.

Note that the two system screens do not allow any data changes since they are only for viewing existing files and not for programming. The screen that shows the directories, although it presents change commands, will not work for security reasons. The user can, however, open the files on the computer and read and make changes, but should refrain from changing the files in the root as this may compromise the operation. The files within the directories can be freely changed or deleted without risk. See details of the following parameters in the Programming Menu screens.

MAIN SCREENS FOR OPERATION

ETHERNET REPORT

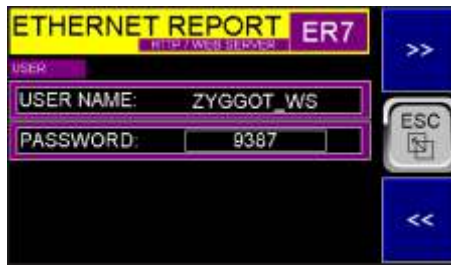
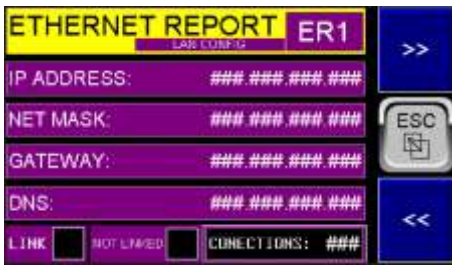

ETHERNET REPORT SCREEN 1 to 9:

There are 9 screens that reproduce the Ethernet Programming Menu, where you can check the various programming conditions without being able to change the programming inadvertently. None of the screens allows commands or changes, with the exception of screen ER3, where you can choose an address and command a PING action to check if a certain device on the network is responding.

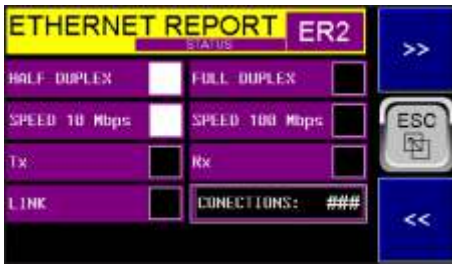

The fields on all these screens will be detailed later. Here we will only comment on the function of each one.

Screens ER1 and ER2 refer to the main Ethernet configuration parameters. Screen ER1 shows the parameters and screen ER2 shows the connection status.



Screen ER3 refers to the ICMP - Internet Control Message Protocol protocol and it is possible to PING the address of a certain device.

Screen ER4 refers to the TCP/IP - Transmission Control Protocol (Modbus TCP Server or Modbus Slave). Through this protocol, Modbus Over Ethernet communication can be performed, using all the parameters and addresses described in the Modbus Map at the end of this manual.



Screen ER4 refers to the TCP/IP - Transmission Control Protocol (Modbus TCP Server or Modbus Slave). This protocol allows Modbus Over Ethernet communication, using all the parameters and addresses described in the Modbus Map at the end of this manual.



Screen ER5 refers to the IP protocol - Internet Protocol (Ethernet IP Server).

The ER6 screen refers to the FTP protocol - File Transfer Protocol. Through which you can read and access the files on the memory card inserted in the respective slot of the relay and where the temperature readings etc. are recorded using a browser.

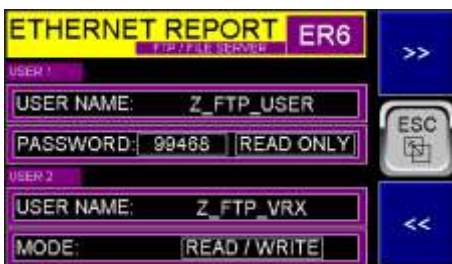

The ER7 screen refers to the HTTP protocol - Hypertext Transfer Protocol.

The ER8 screen refers to the ASCII Over TCP/IP protocol - ASCII Transmission Control Protocol.

The ER9 screen refers to the NTP protocol - Network Time Protocol through which you can obtain precise times from predefined NTP servers.

PROGRAMMING

MENU



In the "Programming Menu" MAIN (Main) there are 13 Sub-items or Submenus available, namely:

- M01: Relay Config.
- M02: Parameters Cfg.
- M03: RCVR/Sensors.
- M04: Block Programming.
- M05: Analog Inputs.
- M06: Modbus Cfg.
- M07: Protections.
- M08: PointAlarm Levels.
- M09: Point Trip Levels.
- M10: Trending Config.
- M11: Clear Data
- M12: Backup/Restore Data
- M13: Ethernet configuration



Sub-item 4 is subdivided as follows:

- M04: Block 1
- M04: Block 2
- M04: Block 1
- M04: Block 2
- M04: Do Block Programm

And sub-item 7 is subdivided into two others, namely:

- M07: Protections 1/2
- M07: Protections 2/2

And sub-item 8 is subdivided into 13

- M8: Point 01-10 to M8: Target 121-125

And sub-item 9 is subdivided into 13

- M9: Point 01-10 to M9: Target 121-125

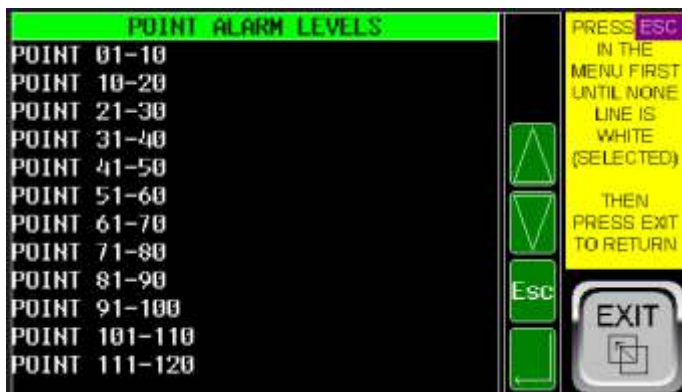

PROGRAMMING

MENU

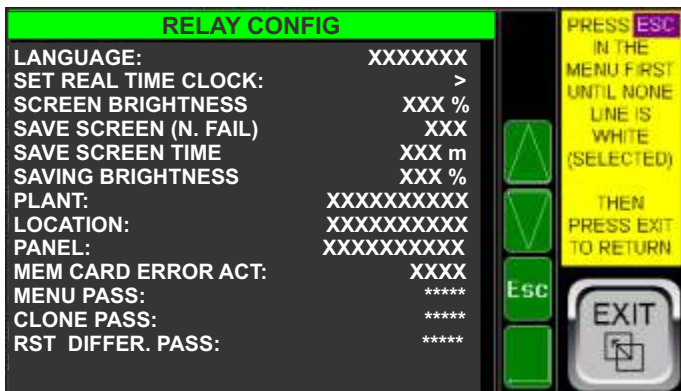

M01- RELAY CONFIG

- 01.1- Language:** (English, Português, Español).
- 01.2- Set Real Time Clock:** Enter the correct date and time, if necessary.
- 01.3- Screen Brightness:** Adjust the screen brightness between 50 and 100% for normal operating conditions.
- 01.4- Save Screen (N. Fail):** Select Yes to start reducing the screen brightness after the time programmed below. No to not perform this action. This action will not be performed if it is in failure (N. Fail) and if it is in screen saving mode and a failure occurs, the screen will return to its normal brightness until the failures are reset.
- 01.5- Save Screen Time:** Adjust the screen inactivity time so that it has reduced brightness. When you touch the screen, the brightness returns to normal and this time starts counting again.
- 01.6- Saving Brightness:** Adjust the screen brightness between 0 and 50% for the screen saving mode.
- 01.7- Plant:** Enter the description of the Plant with a maximum of 10 letters.
- 01.8- Location:** Enter the description of the installation location with a maximum of 10 letters.
- 01.9- Panel:** Enter the description of the panel with a maximum of 10 letters.
- 01.4- Mem Card Error Act:** (None, Log). Select the options None if you do not want a card error alarm to occur or Log if you want the failure to occur.
- 01.10- Menu Pass:** Enter the new Password if necessary, with a maximum of 5 numbers. If set to zero, the programming menu can be accessed by the operator without a password, which entails a risk and is not advisable.
- 01.11- Clone Pass:** Enter the new Password if necessary, with a maximum of 5 numbers to access the Relay Clone menu.
- 01.12- RST Differ. Pass:** Enter the new Password if necessary, with a maximum of 5 numbers to access the Restart Differential Data menu. This request is made to the operator each time the relay is switched on again with active differential data. A new differential cycle can be started from this moment or the initial readings of the differential system valid at the time can be maintained.

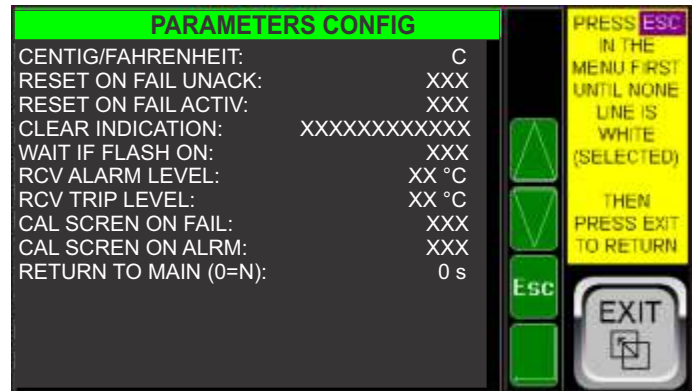

M02- PARAMETERS CONFIG

- 02.1- Centig/Fahrenheit:** (C or F). Select the Temperature unit.
- 02.2- Reset On Fail Unacknowledged:** (Yes, No). Choose Yes to allow Reset with an unacknowledged failure (Ack). The failure is acknowledged on the Alarm screen. It will flash if there is a non-Ack alarm.
- 02.3- Reset On Fail Uncleared:** (Yes, No). Choose Yes to allow Reset with an unacknowledged failure cleared or reset (Clr). The failure is reset on the Alarm screen. It will flash if there is a non-Clr alarm.
- 02.4- Clear Indication:** (Auto, After Reset). If «Auto» is selected, the yellow and red indications on the main temperature screens will return to white if the temperature returns to a value below the alarm or trip point, but the squares indicating Alarm or Trip will remain on until the «Reset» key is pressed. If «After Reset» is selected, the yellow and red colors continue to indicate that an alarm or trip has occurred even if the temperatures have returned to normal, and the small squares remain active. The colors and fault indicators only return to normal after «Reset» is activated. This is the factory condition and is the safest, to indicate faults that have already returned to normal conditions.
- 02.5- Wait if Flash On:** (Yes, No). Condition to return to the main screen automatically, as explained in the «Return to Main» parameter below. If «Yes» is selected, it does not automatically return to the main screen if Flash is On.
- 02.6- RCV Alarm Level:** Alarm level of the receiver body.
- 02.7- RCV Trip Level:** Trip level of the receiver body.
- 02.8- Cal Screen On Fail:** (Yes, No). If set to «Yes», in the event of a fault with Trip, the alarm screen will be automatically displayed.
- 02.9- Cal Screen On Alarm:** (Yes, No). If set to «Yes», the alarm screen will be automatically displayed in the event of an Alarm.
- 02.10- Return to Main:** Time in seconds after which the relay will automatically display the main screen 1. If set to zero, there will be no automatic return. There will also be no automatic return if the screen is in the programming menu or with Flash activated as per parameter 02.4 above.

PROGRAMMING

MENU RCVR/SENSORS, DATA FILE (ALWAYS TO THE SAME FILE)

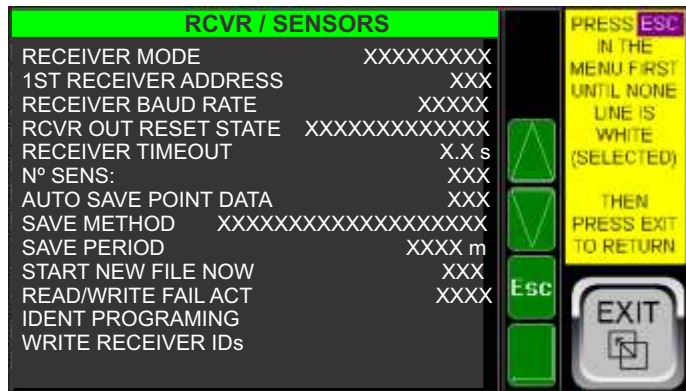

M03-RCVR/SENSORS

03.1- Receiver Reset State: (Out2=Off - Out1=Off, Out2=Off - Out1=On, Out2=On - Out1=Off, Out2=On - Out1=On), choose the desired option. Defines the status of the outputs when Resetting the Receiver.

03.2- No. Sens.: Enter the number of sensors in the network between 1 and 125.

03.3- Auto Save Point Data: (No, Yes), choose whether you want to save the temperature data of all sensors to the memory card, periodically and automatically. See more details below.

03.4- Save Period: (10 to 1440 minutes). If you choose 14440, the values will be saved every 24 hours. You can then start from 10 minutes to 24 hours of interval.

03.5- Save Method: (Always to the Same File, New File Each Start). See more details below.

03.6- Start New File Now: (No, Yes). You can give a command that is equivalent to turning the relay back on, that is, a new file will be created within the directory corresponding to the «New File Each Start» option. See more details below. Note: if option 03.5 is set to «Always to the Same File» this command has no effect.

03.7- Card Write Fail Act: (None, Log). Choose «Log» if you want an Alarm to occur and a memorization of the write failure history in these files.

03.8- Ident Programming: Enter the identifiers of up to 125 sensors, marked on the body of each sensor, between 1 and 65534. Enter 65535 if the point in question is left blank, with no sensor connected.

03.9- Write Receiver IDs: After programming the sensor IDs in item 03.8 above, this option must be used to send the IDs programmed in the relay to the Receiver.

Details of the saving methods reactive to the options in item 03.4 above.

Selecting «Always to the Same File» If «Yes» is selected in item 03.3 above, the data will be automatically saved in a file structure as described and shown below.

Attention: if «New file Each Start» is selected, these files within the **DATAAUTO** directory will remain inactive, not receiving any more data until «Always to the Same File» is selected again.

The data will be within the **DATAAUTO** directory, while the temperature data will be in the **POINTTFILE** file.

The data will be added (Append) separated by commas, to the file with each reading in Excel CSV format, with each line corresponding to a reading. Each time the relay is restarted, a line will be inserted with the data reset to zero for separation purposes and information about the restart.

The **POINTTFILE** file will have the following structure:

dd, mm, yyyy, hh, mm, ss, 0, NS, SR, 0, T1, T2, T3 , Tn

where day, month, year, hour, minute, second, zero separator, Number of total sensors, Number of sensors OK, responding, Zero separator, Temperature of sensor 1, Temperature of sensor 2 up to Temperature of the last programmed sensor. In the example below we have 3 sensors.

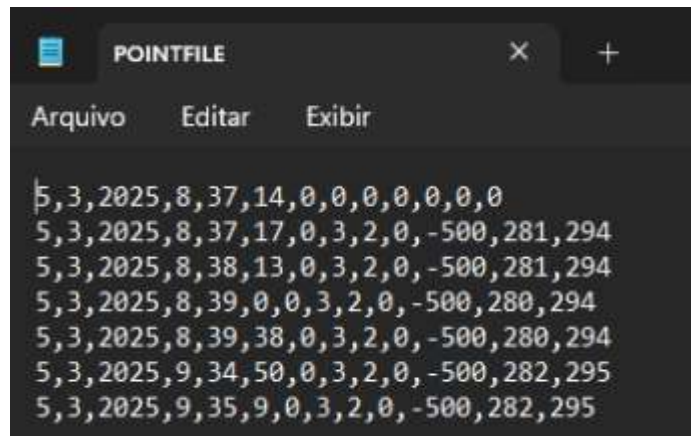
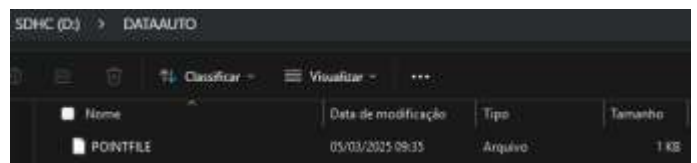
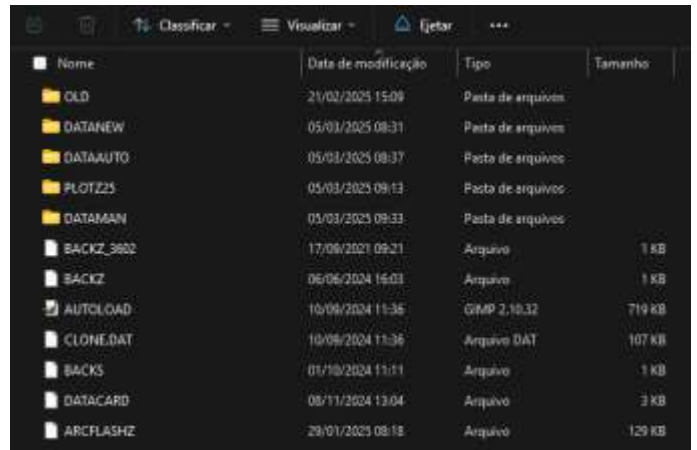

Note that in the example above the initial date of creation of the file is indicated and in the first line and subsequently, with 3 sensors, the date and time of each save is indicated, «0» after as a separator, «3» which is the number of programmed sensors, «2» which is the number of sensors responding, «0» separator, -500 for the first sensor, which is not responding, and the temperatures read for the two sensors responding x10 (without the comma therefore), for example where it reads 294 it is equivalent to 29.4 degrees.

PROGRAMMING

DATA FILE (NEW FILE EACH START)

«**New File Each Start**» Selection If «**Yes**» is selected in item 03.3 above, the data will be automatically saved in a file structure as described and shown below.

Attention: if «**Always to the Same File**» is selected, these files within the **DATANEW** directory will remain inactive, not receiving any more data until «New file Each Start» is selected again.

The data will be within the **DATANEW** directory, subdirectory **POINT**, always with the same names and each of them will contain new subdirectories **DDMMYYYY**, that is, named with the day, month and year of creation of each one, created each time the relay is reconnected or with the «**Start New File Now**» command. And within each of these last subdirectories will be the data files, with names **Thhmm**, that is, T plus the hour and minutes for the Point file.

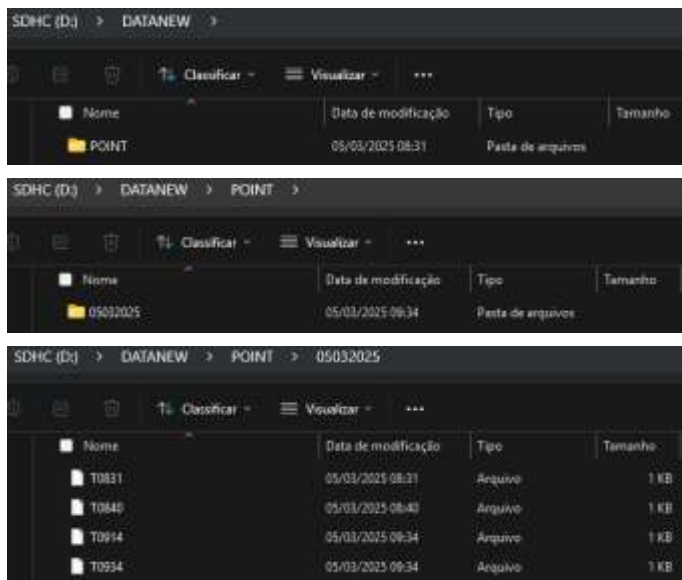

These data files, named **Thhmm**, will have a line for each period end chosen in item **03.4**. with a comma-separated Excel data structure, also with a **CSV** extension.

Note that for this option, data with zeros is not inserted at each restart for marking, as new files are created at each restart, so this insertion is not necessary for information. Note that until the relay is restarted or a «**Start New File Now**» command is given, which is equivalent to turning the relay back on, the temperature data will be added (Append) to the last file created, with one line for each reading, in each period as programmed, with the same structure separated by commas as the previous files, i.e.:

dd, mm, yyyy, hh, mm, ss, 0, NS, SR, 0, T1, T2, T3 Tn
 being day, month, year, hour, minute, second, zero separator, Number of total sensors, Number of sensors responding, Zero separator, Temperature sensor 1, Temperature sensor 2 up to Temperature of the last programmed sensor.

In the following examples, with 3 sensors, you can see the file and data structure for the «**New File Each Start**» option in the same way as described in the «**Always to the Same File**» option on the previous page.

PROGRAMMING

MENU

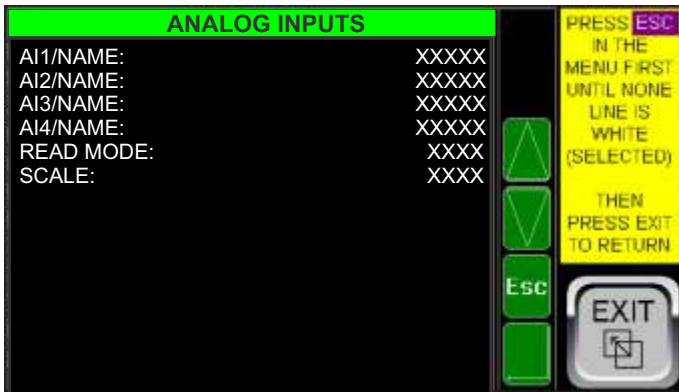

M05- ANALOG INPUTS

05.1- AI1/NAME: Enter the name of the analog input, with up to 5 characters, to facilitate its identification.

05.2-AI2/NAME: Same.

05.3-AI3/NAME: Same.

05.4-AI4/NAME: Same.

05.5-Read Mode: (% , Temp). Reading mode and display on screens, as a percentage in relation to the full scale (5V) or Temperature. The next parameter defines the full scale for the temperature.

05.5.6- Scale: xxxx. Enter the temperature that is equivalent to the full scale (5V) of the analog inputs.

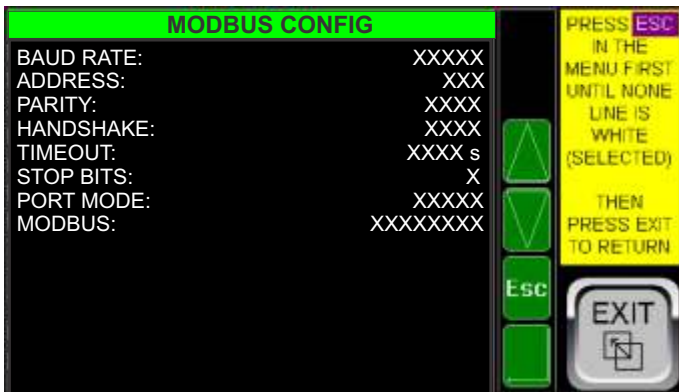

M06- MODBUS CONFIG

This menu is related to the Modbus communication port for the user to optionally connect to the DCS system. (It is not related to the communication port with the sensors)

06.1- Baud Rate: (9600, 19200, 38400) Enter the required Baud Rate.

06.2- Address: (1 to 247): Enter the network node address for this relay.

06.3- Parity: (None, Odd, Even). Choose the required parity.

06.4- Handshake: (None, XON/XOFF, CTS/RTS, MD/HALF), Choose the required Handshake.

06.5- Timeout: (0 to 1023 s). Enter the required Timeout.

06.6- Stop Bits: (1 or 2). Choose the required value. **06.7- Port Mode:** (Rs232, Rs485). Select the mode used.

06.8- Modbus: (Active, Inactive). To turn Modbus on or off. If not used, leave it in «Inactive».

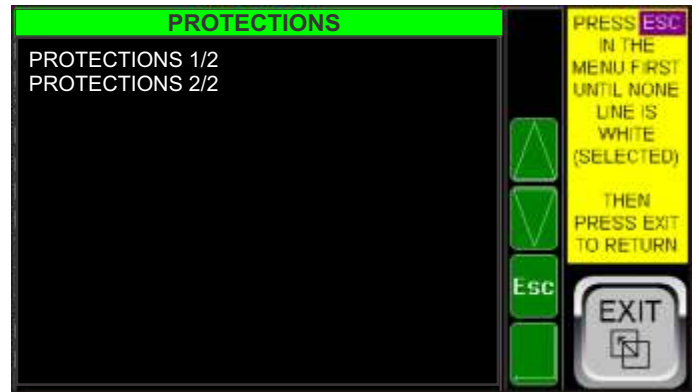

M07- PROTECTIONS

This menu is divided into two (1/2 and 2/2)



M07- PROTECTIONS 1/2

In this menu, the parameters relating to the protections shown above will be programmed.

PROGRAMMING

MENU

ACTION: The selection possibilities for the Action parameter of each of the faults may include one or more options as follows and informed in the parenthetical part of each fault described below and will not be further detailed: (None, Log, Alarm, Trip). In «None» this fault will not be considered. In «Log», it will be logged on the Alarm screen but the Alarm condition will not be triggered. In «Alarm» the fault will be logged and the Alarm condition will be triggered. In Trip, the fault will be logged, the Alarm condition will be triggered and the Trip condition will be triggered. **AUX OUTPUT:** The options for all faults are «None», «D.O.3», «D.O.4», «EB1:Aux1», «EB2:Aux2», «EB3:Aux3», «EB4:Aux4»..... «EB8:Aux8". This will not be detailed in each fault description below, what is described here applies to all of them. Note that the outputs «D.O.1» and «D.O.2» are dedicated to «Alarm» and «Trip» and the outputs D.O.3 and D.O.4 are programmable and are located on the relay while the others, also programmable, are located on the EBLOCK 88x expansion block.

Note: More than one fault can be assigned to the same output and it will switch if any of the faults assigned to it occur.



M07.1- NOT RESPONDING

This fault will occur if one or more sensors are not responding in the sensor network.

07.1.1- Action: (None, Log, Alarm). Choose the desired option.

07.1.2- Aux Output: (None, D.O.3, D.O.4, EB1: Aux1 to EB8: Aux8). Choose the desired option.

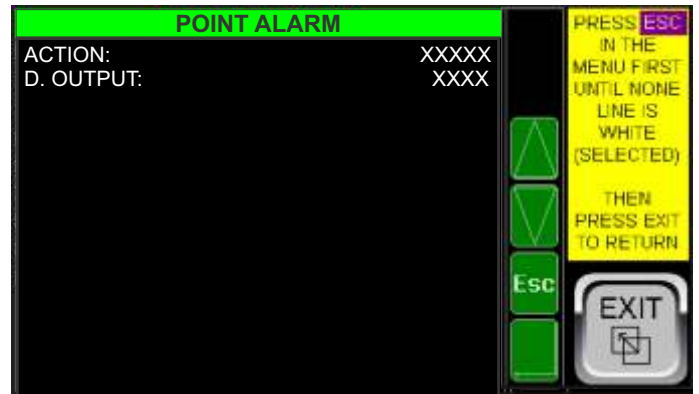

M07.2- POINT ALARM

This fault will occur if one or more sensors reach the alarm temperature level for the target, programmed for each of them in the corresponding menu.

07.2.1- Action: (None, Log, Alarm). Select the option. Note that there is no «Trip» option.

07.2.2- D. Output: (None, D.O.3, D.O.4, EB1: Aux1 to EB8: Aux8). Select the option.



M07.3- POINT TRIP

This fault will occur if one or more sensors reach the Trip temperature level for the target, programmed for each of them in the corresponding menu.

07.3.1- Action: (None, Log, Trip). Choose the option. Note that there is no «Alarm» option which will also be triggered together with the Trip.

07.3.2- Aux Output: (None, D.O.3, D.O.4, EB1: Aux1 to EB8: Aux8). Choose the option.

PROGRAMMING

MENU

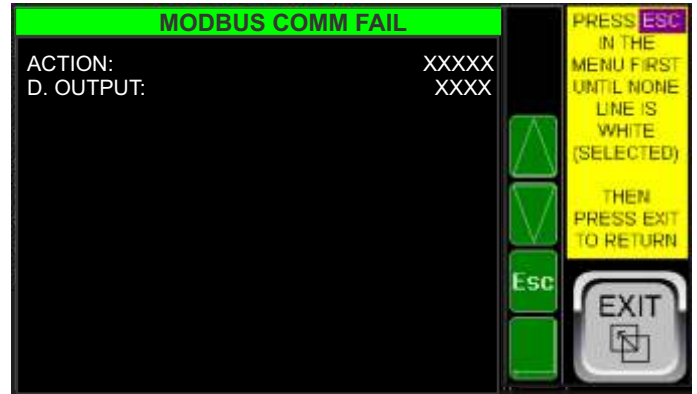
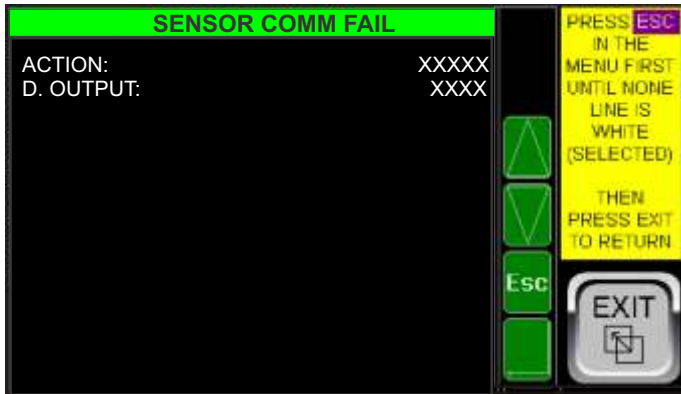

M07.6- SENSOR COMM FAIL

This fault will occur if the sensor network presents a fault, which is shown on the main screen (MS6) as already described in the section corresponding to this screen and whose fault type is shown on this screen.

07.6.1- Action: (None, Log, Alarm). Choose the desired option. Note that there is no Trip option because this is not an important fault that could trip the system, and therefore can be fixed.

07.6.2- Aux Output: (None, D.O.3, D.O.4, EB1: Aux1 to EB8: Aux8). Choose the desired option.

M07.7- MODBUS COMM FAIL

This fault will occur if the sensor network presents a fault, which is shown on the main screen (Ms6) as already described in the section corresponding to this screen and whose fault type is shown on this screen.

07.7.1- Action: (None, Log, Alarm). Choose the desired option. Note that there is no Trip option because this is not an important fault that could trip the system, and therefore can be fixed.

07.7.2- Aux Output: (None, D.O.3, D.O.4, EB1: Aux1 to EB8: Aux8). Choose the desired option.

PROGRAMMING

MENU

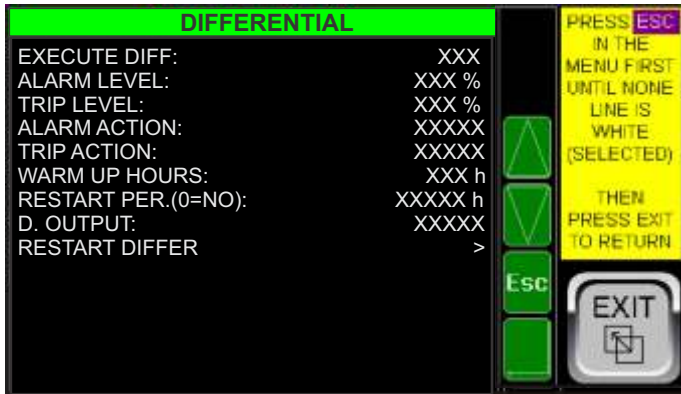

M07.8- DIFFERENTIAL

This fault will occur if the differential fault is programmed to be executed and the temperature rises in relation to the first measurement as programmed.

07.8.1- Execute Diff: (Yes, No). Choose «Yes» to activate this protection or «No» to not activate it.

07.8.2- Alarm Level: Enter the Alarm level as a percentage of the initial reading.

07.8.3- Trip Level: Enter the Trip level as a percentage of the initial reading.

07.8.4- Alarm Action: (None, Log, Alarm). Note that there is no Trip option.

07.8.5- Trip Action: (None, Log, Trip). Note that there is no Alarm option which will occur together with the Trip option.

07.8.6- Warm Up Hours: Enter the warm up time in hours required to take the first measurement. The first measurement is taken with the system warmed up and stabilized. In environments with high variations in ambient temperature, do not choose an alarm or trip level that is too tight, taking into account the variation in ambient temperature as well.

07.8.7- Restart Period: (0=No) Enter the period for the automatic restart of the function, i.e., for taking a new measurement. The restart can also be manual, at any time, performed in item 08.7.9 below. Note that if zero is entered, it is equivalent to never performing the automatic restart.

07.8.8- Aux Output: (None, D.O.3, D.O.4, EB1: Aux1 to EB8: Aux8). Choose the desired option.

07.8.9- Restart Differ: This item directs you to the screen that will perform the restart of the differential (shown below), performing a new initial reading when the action is confirmed in the «Proceed?» button with the «Yes» option.

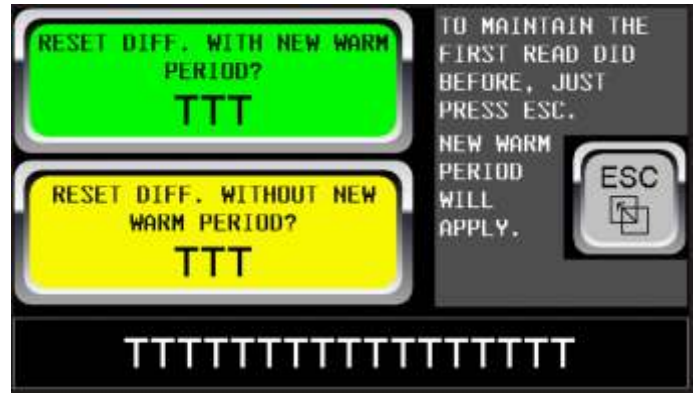

07.8.9- Restart Differential: If the green button is pressed, there will be a new reading of the initial reference temperatures for the differential after the new warm-up period has been counted.

If the yellow button is pressed, there will be a new reading immediately, without the warm-up period. Only use the yellow button if you are sure that the system is at a stable temperature at the moment.]

This screen will also appear after the relay is switched off in a valid differential condition, i.e. with the indication «Valid» so that the operator can decide whether to continue with the data previously read and saved for the differential reference or to start the differential with a new reading.

To keep the old data, simply press «ESC».



M07.9- OPERATING TIME

This fault will occur if the fault is programmed to be executed in «Action» and the On Time is greater than the programmed one. This fault is used to schedule any preventive maintenance on the system, although the Zyggot system itself does not require any preventive maintenance for at least 10 years.

07.9.1- Action: (None, Log, Alarm). Choose the desired option. Note that there is no Trip option.

07.9.2- Hours: Enter the number of On hours to activate this protection (max = 250000 h).

07.9.3- Aux Output: (None, D.O.3, D.O.4, EB1: Aux1 to EB8: Aux8). Choose the desired option.

PROGRAMMING

MENU



M07.11- GROUP

This menu is subdivided into 5 (Group 1 to Group 5). Only the programming of group 1 will be detailed. The others are identical.



M07-PROTECTIONS 1/2

Neste menu serão programados os parâmetros relativos às proteções mostradas acima. A numeração dos submenus seguirá a seqüência do menu 7- Protections

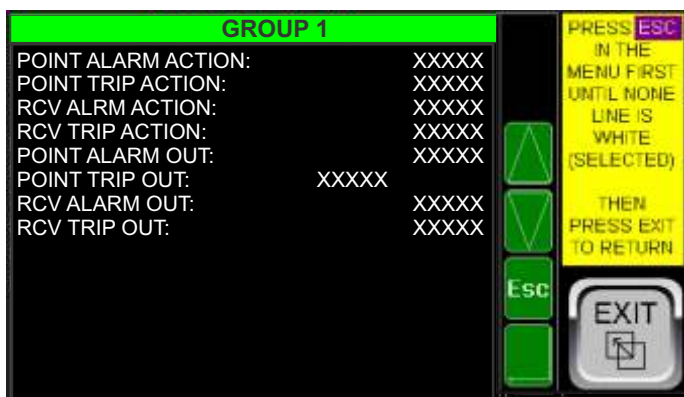

M07.11- GROUP 1

This fault will occur if any of the sensors assigned to this group are in Alarm or Trip condition.

07.11.1- Point Alarm Action: (None, Log, Alarm). Note that there is no Trip option.

07.11.2- Point Trip Action: (None, Log, Trip). Note that there is no Alarm option which will occur together with the Trip option.

07.11.3- RCV Alarm Action: (None, Log, Alarm). Note that there is no Trip option.

07.11.4- RCV Trip Action: (None, Log, Trip). Note that there is no Alarm option which will occur together with the Trip option.

07.11.5- Point Alarm Out: (None, D.O.3, D.O.4, EB1: Aux1 to EB8: Aux8). Choose the desired option. **07.11.6- Point Trip Out:** (None, D.O.3, D.O.4, EB1: Aux1 to EB8: Aux8). Choose the desired option.

07.11.7- RCV Alarm Out: (None, D.O.3, D.O.4, EB1: Aux1 to EB8: Aux8). Choose the desired option.

07.11.8- RCV Trip Out: (None, D.O.3, D.O.4, EB1: Aux1 to EB8: Aux8). Choose the desired option.



M07.12-ANALOG 1 ALARM

This fault will occur if the fault is programmed to be executed in «Action» and the value of analog input 1 exceeds the programmed level.

07.12.1- Action: (None, Log, Alarm). Choose the desired option. Note that there is no Trip option.

07.12.2- Level High: Enter the level in % of full scale.

07.12.3- D. Output: (None, D.O.3, D.O.4, EB1: Aux1 to EB8: Aux8). Choose the desired option.

M7.14-ANALOG 2 ALARM - ditto M7.12

M7.16-ANALOG 3 ALARM - ditto M7.12

M7.18-ANALOG 4 ALARM - ditto M7.12

PROGRAMMING

MENU

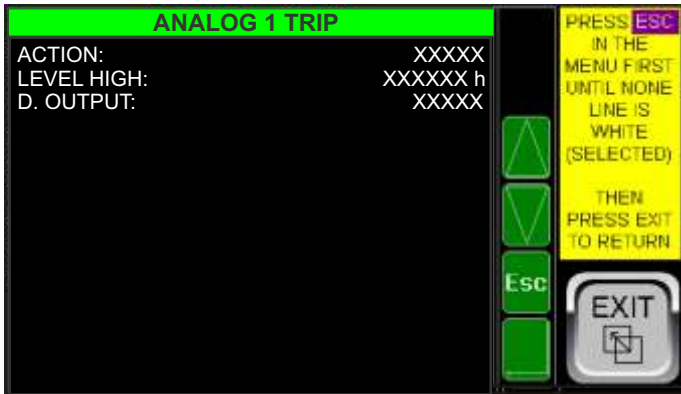

M07.13-ANALOG 1 TRIP

This fault will occur if the fault is programmed to be executed in «Action» and the value of analog input 1 exceeds the programmed level.

07.13.1- Action: (None, Log, Alarm). Choose the desired option. Note that there is no Alarm option which will occur together with the Trip.

07.13.2- Level High: Enter the level in % of the full scale.

07.13.3- Aux Output: (None, D.O.3, D.O.4, EB1: Aux1 to EB8: Aux8). Choose the desired option.

M7.15-ANALOG 2 TRIP - ditto M7.13

M7.17-ANALOG 3 TRIP - ditto M7.13

M7.19-ANALOG 4 TRIP - ditto M7.13



M07.20- EXTERNAL FAIL 1

This fault will occur if the fault is programmed to be executed in «Action» and the corresponding digital input becomes active.

07.20.1- Action: (None, Log, Alarm, Trip). Choose the desired option. Note that if there is no Alarm option, the Trip will not be activated, and if the Trip option is selected, the Trip output and the Alarm output will be activated if configured for this purpose. If «Log» is selected, only the fault will be logged on the Alarms and History screen, but the alarm or trip condition will not be activated.

07.20.2- Trip Delay: Delay time that occurs after the digital input becomes active and the fault is detected.

07.20.3- Aux Output: (None, D.O.3, D.O.4, EB1: Aux1 to EB8: Aux8). Choose the desired option. 07.20.4- Assign Name: Enter the name of the Digital entry with up to 5 characters to facilitate its identification in the system.

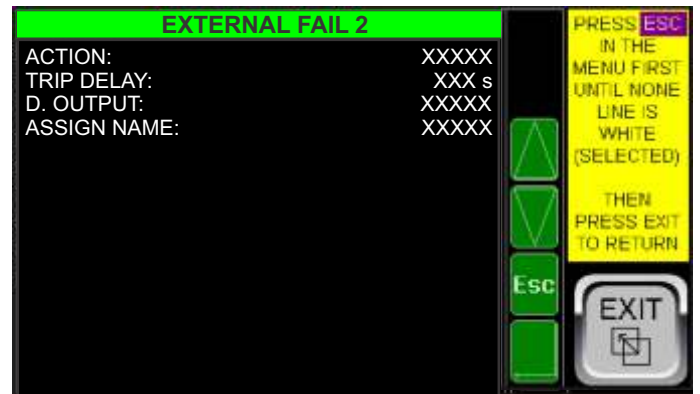

M07.21- EXTERNAL FAIL 2

This fault will occur if the fault is programmed to be executed in «Action» and the corresponding digital input becomes active.

07.21.1- Action: (None, Log, Alarm, Trip). Choose the desired option. Note that if there is no Alarm option, the Trip will not be activated, and if there is a Trip option, the Trip output and the Alarm output will be activated if configured for this purpose. If «Log» is chosen, only the fault will be logged on the «Alarms» and «History» screens, but the alarm or trip condition will not be activated.

07.21.2- Trip Delay: Delay time that occurs after the digital input becomes active and the fault is detected.

07.21.3- Aux Output: (None, D.O.3, D.O.4, EB1: Aux1 to EB8: Aux8). Choose the desired option. 07.21.4- Assign Name: Enter the name of the Digital entry with up to 5 characters to facilitate its identification in the system.

PROGRAMMING

MENU

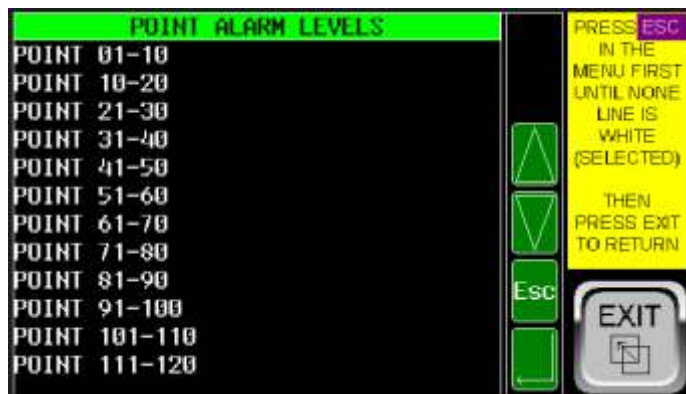

M08-POINT ALARM LEVELS

In these Submenus you can enter each Alarm temperature level for the target or edit the levels that were automatically set by the Group Programming submenu.

M09-POINT TRIP LEVELS

In these Submenus you can enter each Trip temperature level for the target or edit the levels that were automatically set by the Group Programming submenu.



M08.1- POINT 01 - 10 ALARM LEVELS

08.1.1- A1 a 08.1.10-A2 Enter or edit the level in degrees Celsius or Fahrenheit for the target alarm level.

M09.1- POINT 01 - 10 TRIP LEVELS

09.1.1- A1 a 09.1.10-A2 Enter or edit the level in degrees Celsius or Fahrenheit for the target alarm level.

- M08.2- POINT 11 - 20 ALARM LEVELS
- M08.3- POINT 21 - 30 ALARM LEVELS
- M08.4- POINT 31 - 40 ALARM LEVELS
- M08.5- POINT 41 - 50 ALARM LEVELS
- M08.6- POINT 51 - 60 ALARM LEVELS
- M08.7- POINT 61 - 70 ALARM LEVELS
- M08.8- POINT 71 - 80 ALARM LEVELS
- M08.9- POINT 81 - 90 ALARM LEVELS
- M08.10- POINT 91 - 100 ALARM LEVELS
- M08.11- POINT 101 - 110 ALARM LEVELS
- M08.12- POINT 111 - 120 ALARM LEVELS
- M08.13- POINT 121 - 125 ALARM LEVELS

Same as M8.1 above

- M09.2- POINT 11 - 20 TRIP LEVELS
- M09.3- POINT 21 - 30 TRIP LEVELS
- M09.4- POINT 31 - 40 TRIP LEVELS
- M09.5- POINT 41 - 50 TRIP LEVELS
- M09.6- POINT 51 - 60 TRIP LEVELS
- M09.7- POINT 71 - 80 TRIP LEVELS
- M09.9- POINT 81 - 90 TRIP LEVELS
- M09.10- POINT 91 - 100 TRIP LEVELS
- M09.11- POINT 101 - 100 TRIP LEVELS
- M09.12- POINT 111 - 120 TRIP LEVELS
- M09.13- POINT 121 - 125 TRIP LEVELS

Same as M9.1 above

PROGRAMMING

MENU



M12- BACKUP / RESTORE DATA

M12.1- Enable Autorun: Auto Run must be enabled as well as Auto Load if it is desired to have the Fail-Safe system operational. After Auto Load has been executed, if the relay detects that the program is missing or corrupted.

M12.2- Enable AutoLoad: Must be enabled in the same way as described above.

M12.3- Flash Backup: This sub-menu directs you to the screen below where you can clear the backup previously executed or perform a first or new backup of the entire RAM memory to the internal Flash memory. This internal backup is used in the event of a Fail-Safe action with Auto Load and Auto Run.

Only execute the Make Backup command after having programmed all the parameters and being sure that the relay is operating correctly and without active or uncleared faults on the alarm screen.

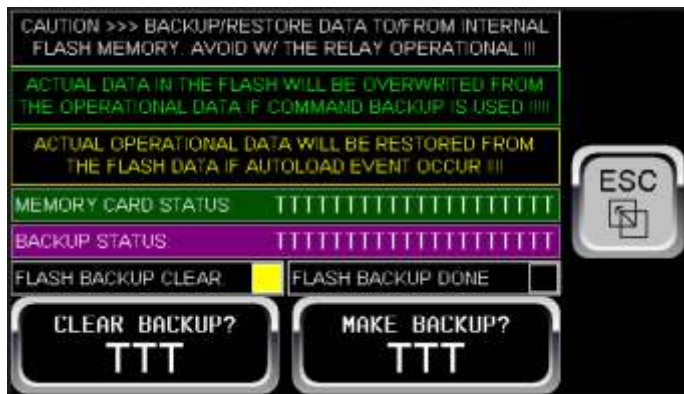

In addition to the Clear Backup and Make Backup buttons and the Cleared or Done indications, there is a memory card status field, as described previously, and a Backup Status field, with the messages described previously on the MS10 Screen, which can be: 1- STANDBY / 2- OK - PROCEED / 3- ERROR - CHECK CARD / 4- DONT BACKUP ON FAIL / 5- OK - DONE / 6- WRITING / 7- READING / 8- BUSY.

Note that the Clear Backup and / Make Backup command buttons are invisible if the conditions for these commands are not suitable at the time.

M12.2- CLONE PARAMETERS

This submenu takes you to the Clone Parameters screen below. **WARNING:** This action, if «Restore» is commanded, will overwrite all programming parameters with those contained in the memory card, in the specific file.

To use this function, a previously formatted memory card, with a maximum of 32 Gb, must be inserted in the upper slot of the relay. You can command «Backup» to save a new file with the data or «Restore» to restore the same.

In this way, if several Zyggot RADDIA Relays are used with the same programming, simply program one of them and clone the data in the other relays.

This action does not save or restore the programming password, which is in fact one of the parameters.

On the screen below, you can see that there are two fields, one with the card status messages as described in the explanation of the Info 4 screen and another with the Backup status messages as described previously on the MS10 Screen, which are: 1- STANDBY / 2- OK - PROCEED / 3- ERROR - CHECK CARD / 4- DONT BACKUP ON FAIL / 5- OK - DONE / 6- WRITING / 7- READING / 8- BUSY.

Note that the Backup and Restore command buttons are invisible if the conditions for these commands are not suitable at the time.

Note: Unlike the Flash Backup command, which copies the entire RAM memory to a non-volatile internal memory, the Clone Parameters command described here only saves the values of the parameters entered in the programming menu and serves as documentation to be saved, such as possible restoration of parameters to a previous condition when changes are made to the programming or, as already mentioned, cloning the same parameters in other relays of the same plant, for example.

To clone the parameters to other relays, copy the «Datacard» file from the memory card of the relay that generated the file to be cloned to the cards of the other relays onto a computer and then run the Restore command on each of them. Attention: In this case, be careful not to run the Backup command on the other relays before running the Restore command.

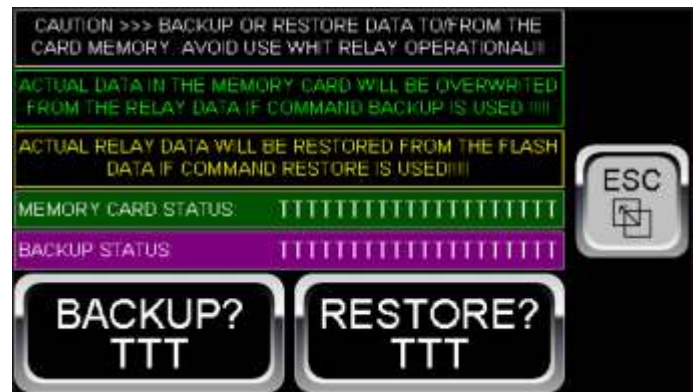

PROGRAMMING

MENU

M13-ETHERNET

The ZYGGOT RADDIATS Relay has ETHERNET communication and can be accessed from anywhere on the planet. Several communication protocols are incorporated, and the user simply needs to define the communication parameters on the programming screens below and use it.

For example, all temperature readings and flag statuses can be obtained from a computer or mobile device or even interfaced with a DCS system anywhere, as long as there is access to Ethernet and the relay is connected to a local LAN network with access to an external WAN network and the addresses programmed into the relay are known.

The relay can be parameterized remotely if necessary, such as alarm and trip levels, etc.

The manufacturer can also perform any firmware updates remotely, if necessary.

The available protocols are:

- ICMP - Internet Control Message Protocol.**
- SRTP - Service Request Transport Protocol.**
- TCP/IP - Transmission Control Protocol (Modbus TCP Server or Modbus Slave).**
- ETHERNET/IP - Internet Protocol (Ethernet IP Server).**
- FTP - File Transfer Protocol**
- HTTP - Hypertext Transfer Protocol.**
- ASCII Over TCP/IP - ASCII Transmission Control Protocol.**
- NTP - Network Time Protocol.**

This manual does not intend to cover each protocol in depth. It is up to the user to know the protocol they intend to use.

The following is a brief description of each Protocol and their limitations in this application.

ICMP - Internet Control Message Protocol. Internet Control Message Protocol), is a protocol that is part of the IP Protocol, defined by RFC 792, and is used to communicate network layer information, the most common use being to provide error reports to the original source. Any computer that uses IP must accept ICMP messages.

Although several tools are possible in this protocol, the Zyggot Raddia relay only implements the Ping function, which can be used to check whether a device is responding to commands, i.e. is accessible on the network.

SRTP - Service Request Transport Protocol. Service Request Transfer Protocol (SRTP) is a GE Fanuc Automation protocol that allows a remote SRTP client to request services from an SRTP server. In this case, the ZYGGOT RADDIATS relay, which acts as an SRTP server, responding to requests from one or more SRTP Clients.

Since SRTP was originally designed to support the services provided by GE Fanuc Series 90, the ZYGGOT Raddia SRTP protocol does not support all possible SRTP services. The ZYGGOT Raddia Relay's implementation of SRTP is mainly limited to the services required for the exchange of log data.

Configuration:

Port Used: 18245 TCP

Maximum Number of Connections: 16

The following SRTP service requests are supported by ZYGGOT RADDIATS Relay.

- 0 PLC_SSTAT**
- 1 PLC_LSTAT**
- 4 READ_SMEM**
- 7 WRITE_SMEM**
- 33 CHG_PRIV_LEVEL**
- 67 RET_CONFIG_INFO**
- 79 SESSION_CONTROL**
- 97 PLC_FEATURES_SUPP**

Record Types:

- 8 %R 16 bit**
- 10 %AI 16 bit**
- 12 %AQ 16 bit**
- 16 %I 8 bit**
- 18 %Q 8 bit**
- 20 %T 8 bit**
- 22 %M 8 bit**
- 30 %S 8 bit**
- 70 %I 1 bit**
- 72 %Q 1 bit**
- 74 %T 1 bit**
- 76 %M 1 bit**
- 84 %S 1 bit**

TCP/IP - Transmission Control Protocol (Modbus TCP Server). The TCP/IP protocol is an acronym for Transmission Control Protocol, used when sending and receiving data on the web.

The TCP/IP protocol is the language of computers and specifies how data is exchanged over the Internet.

Most computers communicate using TCP/IP, providing end-to-end communications.

Highly scalable and widely used, this protocol requires little central management and was designed to make networks reliable, with the ability to automatically recover in the event of a device failure. Each device has an IP address that identifies it, allowing it to communicate and exchange data with other connected devices.

Configuration:

Port Used: 502 TCP

Maximum Number of Connections: 16

Note: Modbus must be enabled on the Zyggot RADDIATS Relay.

MENU

ETHERNET/IP - Internet Protocol (Ethernet IP Server). The Internet Protocol (IP) is the network layer communications protocol in the Internet protocol suite for relaying datagrams across network boundaries (Maintained by ODVA.org). Its routing function enables the interconnection of networks and essentially establishes the Internet.

IP is tasked with delivering packets from the source host to the destination host based solely on the IP addresses in the packet headers. To do this, IP defines packet structures that encapsulate the data to be delivered. It also defines addressing methods that are used to label the datagram with source and destination information. Configuration:

Ports Used: 44818 TCP or 2222 UDP

Maximum Number of Connections: 2

Start Send (Produced) Register = R2001 /// Words Count = 248

Start Received (Consumed) Register = R2501 /// Words Count = 199 /// Status Register = R5513

FTP - File Transfer Protocol is the protocol that allows file transmission over the network. Through it, you can read and access files on the memory card inserted in the respective relay slot and where temperature readings, etc., are recorded. It is a standard/generic hardware-independent protocol for transferring files and is also a transfer program.

Data transfer in computer networks usually involves transferring files and accessing remote file systems (with the same interface used for local files). FTP is based on TCP, but predates the TCP/IP protocol stack, and was later adapted to it. It is the standard for transferring files.

Configuration:

Ports Used: 20 and 21 TCP

Maximum Number of Connections: 4

User Name 1 (Read Only) = Z_FTP_USER /// Password = 899468 /// User Name 2 (Read / Write) = Z_FTP_VRX ///

Password = xxxx

HTTP - Hypertext Transfer Protocol.

The Hypertext Transfer Protocol is a communication protocol (at the application layer according to the OSI Model) used for distributed and collaborative hypermedia information systems. It is the basis for data communication on the World Wide Web.

Hypertext is structured text that uses logical connections (hyperlinks) between nodes containing text. HTTP is the protocol for the exchange or transfer of hypertext.

Configuration:

Port Used: 80 TCP

Maximum Number of Connections: 1

User Name: = ZYGGOT_WS

Password: 9387

ASCII Over TCP/IP - ASCII Transmission Control Protocol. The **ASCII Transmission Control Protocol**, or **ASCII TCP**, is a query/response/question-and-response communication protocol in which a host PC uses ASCII characters to send commands to a device and receive responses from the device.

This protocol is designed to send and receive ASCII data over the Zyggot Relay's Ethernet port. The Relay acts as a server when using this protocol.

Configuration:

Port Used: Entered in Configuration.

Tx Trigger: %M100 (transmits 500 Bytes when set = 1

Tx Bytes (8 bits) 500 Bytes (250 Words) in the sequence Bytes 1 and 2 form Word 1 containing the temperature of Target 1, Bytes 2 and 3 containing the temperature of Target 2 and so on until completing 125 sensors, when the Air temperatures of Sensor 1, Sensor 2 etc. are completed until completing 125 sensors, therefore totaling 500 Bytes (250 Words).

Rx Copy Trigger: %M99 (copies 504 Bytes (252 Words) when set = 1 for the alarm and Trip parameters. Before being set, the user must transmit all the Bytes already configured as half a Word each, referring to the integer value of the alarm levels for each sensor.

Rx Bytes (8 Bits) 504 Bytes (252 Words): The first 500 bytes must form 250 words referring to the target alarm levels for 125 sensors, then trip levels for 125 sensors and the last 4 bytes must form the 2 words referring to the alarm and trip levels for all sensors (always the same for all).

Maximum number of connections: 1

NTP - Network Time Protocol. NTP is a protocol for synchronizing equipment clocks based on the UDP protocol on port 123. It is used to synchronize the clock of a set of equipment and devices in data networks with variable latency. NTP allows the clock of an equipment to be synchronized with the correct time at all times and with great accuracy.

Configuration: Five NTP server addresses are predefined in Brazil. Upon request, we can define any other server worldwide.

The factory predefined servers are as follows. a.st1.ntp.br

b.st1.ntp.br

c.st1.ntp.br

d.st1.ntp.br

gps.st1.ntp.br

PROGRAMMING

MENU

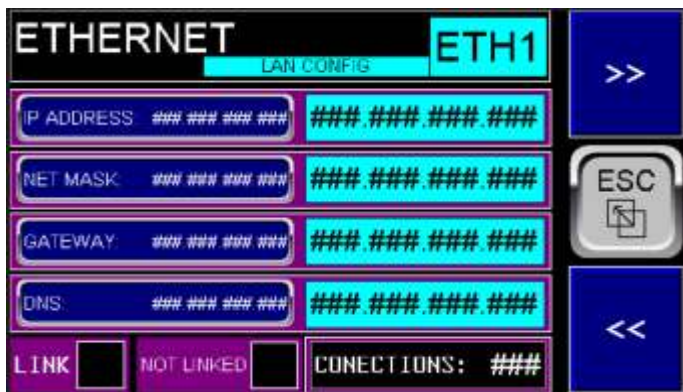

M13A-ETHERNET - LAN CONFIG

M13A.1- IP ADDRESS: Enter the address of the Zyggot Raddia relay on the LAN network.

M13A.2- NET MASK: Enter the number corresponding to the network mask. Normally 255.255.255.0

M13A.3- Gateway: Enter the number corresponding to the Gateway if necessary. If not necessary, leave it at 0.0.0.0

M13A.4- DNS: Enter the Domain Name Server address if necessary. If not used, leave it at 0.0.0.0

This screen also shows whether the Ethernet cable is connected or not and the number of connections. Note: the number of connections may eventually show «zero» even though it is connected if the transmissions are not repetitive and because it is very fast, there is not enough time to show it on the screen.



M13C-ETHERNET - ICMP (PING)

This screen, like the corresponding screen in the Report Menu, allows you to test whether a specific device on the network is responding, i.e., is active on the network.

M13C.1- PING ADDRESS: Enter the address to perform the ping.

M13C.2- PING RESPOND TIME: Shows the time in milliseconds that the device took to respond.

M13C.3- Tx and Rx: Shows whether it is transmitting or receiving data.

M13C.4- PING TIMEOUT: If the device does not respond in less than 1 second, it will indicate Timeout, i.e., it is not responding.

M13C.5- STAR and STOP: Starts and stops the PING. When exiting the screen, a Stop is automatically given.

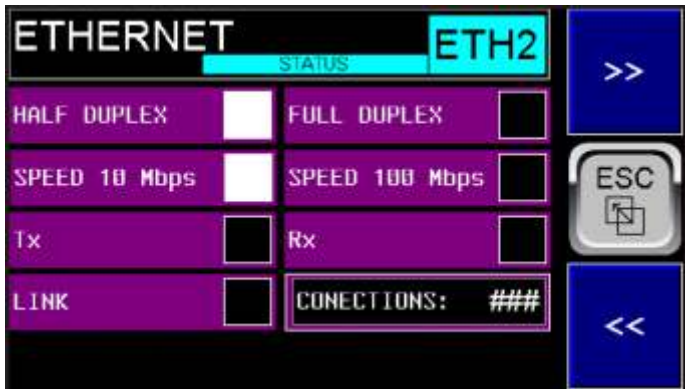

M13B-ETHERNET - STATUS

This screen only shows the various connection statuses, and does not have any fields to be entered.

The statuses shown are:

M13B.1- HALF DUPLEX or FULL DUPLEX: Shows the connection mode.

M13B.2- SPEED 10 Mbps or 100 Mbps: Shows the connection speed.

M13B.3- Tx and Rx: Shows whether data is being transmitted or received.

M13B.4- LINK: Whether the Ethernet cable is connected (Link) or not and the number of connections. Note: the number of connections may eventually show "zero" but it is connected if the transmissions are not repetitive and because they are very fast there is not enough time to show it on the screen.

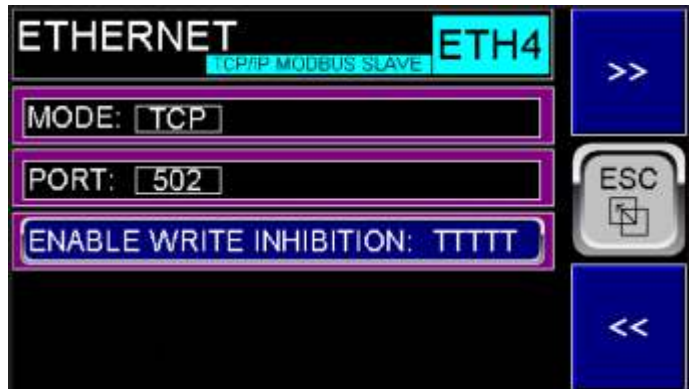

M13D-ETHERNET - TCP/IP PROTOCOL - MODBUS SLAVE

This screen refers to the main protocol of the Zyggot RADDIA TS relay, which allows full Modbus operation, with all functionalities and valid addresses, as well as offsets, etc.

The SUPERGER program provided free of charge by Varixx allows, among other functionalities, complete testing of the Modbus Over Ethernet connection with a computer connected to the Zyggot RADDIA Relay.

PROGRAMMING

MENU

M13D.1- MODE: Informational field only. Shows the mode (Always TCP).

M13D.2- PORT: Informational field only. Shows the port (Always 502)

M13D.3- ENABLE WRITE INHIBITION: Select **YES** to inhibit any possibility of writing to internal parameters of the Zyggot RADDIA TS relay, thus increasing safety. Readings of any records or parameters, Temperatures, Flags, etc. continue to be functional if write inhibition is selected as Yes or Yes.

Note: Always prefer to program the parameters directly on the relay or through the memory card, as described in this manual, for safety reasons.



M15E- ETHERNET IP PROTOCOL

This screen refers to the Ethernet IP protocol. Unlike the TCP/IP (Modbus Over Ethernet) protocol described above, the data read and written will be transferred all at once, respecting the maximum number of words, as described below.

M15E.1- READING PAGE: From 0 to 16 for reading up to 128 words per page. Corresponds to record **%R2927** in the Ethernet IP Server table.

M15E.2- REGISTERS (PRODUCED): For informational purposes only. Always **%R2801** to **%R2928**: will contain the various words with data according to the ETHERNET IP Server table later in this manual.

M15E.3- DATA VALID (in the PRODUCED section): For informational purposes only. For informational purposes only on this screen. The corresponding word in the Ethernet IP Server table (**%R2928**) will have the value 1, that is, its bit 1 will be set when the data is valid after the page to be read has been changed. If there is no page change, this bit will remain set indefinitely, and if there is a page change, it will briefly go to zero and then to 1 again when the data read has been changed.

M15E.4- WRITING PAGE: From 0 to 16 to write up to 128 words on each page. Corresponds to register **%R3226** in the Ethernet IP Server table. (Note: Not enabled in this version. Only page 0 will be effective - see table).

M15E.5- REGISTERS (CONSUMED): For informational purposes only. Always **%R3201** to **%R3328**: will contain the various words to be written to the relay with data according to the ETHERNET IP SERVER table later in this manual. (Note: Not enabled in this version. Only page 0 will be effective - see table).

M15E.6- PROGRAM PERMISSION: Can be set to "Enabled" or "Disabled" to allow or not the programming of the relay parameters via Ethernet IP. Not enabled in this version, so it is always set to "Disabled"

M15E.7- CONNECTED: Indicates that the Ethernet connection is OK.

M15E.8 - DATA VALID (in the Consumed section): For informational purposes only on this screen. The corresponding word in the Ethernet IP server table (**%R3328**) must be set to value 1, that is, its bit 1 set when the data is valid to be written to the relay after a new writing page is selected. (Note not enabled in this version. Only page 0 will be effective - see table).

M15E.9 and M15E10 - CONNECT CLASS 3 and CONNECT CLASS 1: For informational purposes only.

IMPORTANT NOTE: always prefer to program the parameters directly on the relay or through the memory card, as described in this manual, for safety.

Note that with a single programming of parameters on a relay, the identical programming can be replicated on other relays through the memory card.

PROGRAMMING

MENU

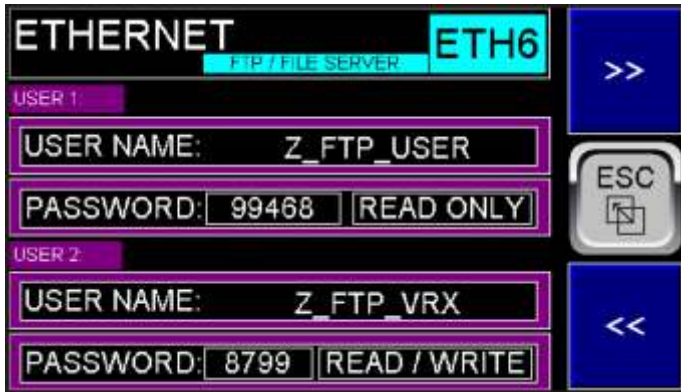

M13F- ETHERNET - FTP PROTOCOL - FILE TRANSFER PROTOCOL

This screen refers to the protocol that enables reading and copying of files stored on the ZYGGOT RADDIA relay memory card, allowing you to obtain historical data records of temperature readings, for example. To access any file on the card, you must know its name as recorded on the card. You must use the file name and its full path (with directories and subdirectories, if any), as in the examples below.

Assuming that the relay IP is **192.168.1.10** and you want to read the **log.txt** file, which is in the root directory of the card

Then type in the search field:

192.168.1.10/log.txt and press Enter.

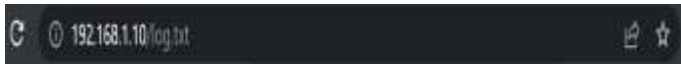

A screen will appear asking for your login and password. Once you have entered the correct login and password details, the file will be read and can be saved on your computer.



M13F.1- USER 1 - USER NAME: Informational only. Always **Z_FTP_USER**.

M13F.2- PASSWORD: Informational only. Always **99468**

M13F.3- READ ONLY. Informational only.

M13F.4- USER 2 - USER NAME: Informational only. Always **Z_FTP_VRX**

M13F.5- PASSWORD: Informational only. Always **8799**.



M13G-ETHERNET - HTTP PROTOCOL - WEB SERVER

This screen refers to the HTTP or HTTPS protocol that allows communication with Browsers using Hypertext Transfer Protocol.

M13G.1- USER NAME: For informational purposes only. Always **ZYGGOT_WS**.

M13G.2- PASSWORD: For informational purposes only. Always **9387**



M13H-ETHERNET IP

This screen refers to the **ASCII OVER TCP/IP** protocol.

M13H.1- BY NUMBER: Enter the desired port.

M13H.2- Tx BYTES: For information purposes only. Always 500 (250 Words).

M13H.3- Tx TRIGGER (%M100): When this flag is set to one, 500 Bytes will be transmitted in ASCII format, which must be combined (transformed into 250 16-bit Words that will contain the target and air temperatures of up to 125 sensors).

M13H.4- Rx BYTES: For informational purposes only. Always 506 (253 Words).

M13H.5- COPY ENABLED: Indicates whether copying of buffer records to the real records is currently enabled. To indicate «enabled», the «**Status Received**» must be ok and there must be no «**Rx Overflow**» or «**Socket**» errors.

M13H.6- STATUS RECEIVED: Indicates that 504 Bytes (252 Words) have been successfully received.

After writing the data to be programmed, as per the table at the end of this manual, by setting the Flag corresponding to «**Copy Trigger**» the data is copied to the corresponding parameters of the Zyggot Raddia relay.

This data will be transferred to the parameters according to the table at the end of this manual.

PROGRAMMING

MENU

M13H.6- COPY TRIGGER: In this field, choose the method to copy the data from the Buffer region to the real parameter registers. Two options can be chosen: «%M99» or «BYTE T».

If %M99 is selected, at the end of the data transmission to the relay, the %M99 Flag must be set to validate the data, when the relay will copy the data to the real parameter registers and reset the %M99 flag. To set the %M99 Flag, the normal TCP/IP Protocol must be used.

If BYTE T (Byte Termination) is selected, the last bit of the second word transmitted (composed of Bytes 3 and 4) must be set. The first word (Bytes 1 and 2) must contain the number of bytes to be transmitted to the relay (always 506).

After writing the data to be programmed, starting from Byte 5 and 6, according to the table at the end of this manual, when setting the «Copy Trigger» Flag (%M99 or BYTE T) the data is copied from the internal buffer region to the real parameters of the Zyggot Raddia relay.

M13H.7- Rx OVERFLOW STATUS: Indicates Overflow error in reception.

M13H.8- Tx OVERFLOW STATUS: Indicates Overflow error in transmission.

M13H.9- SOCKET STATUS: Indicates Socket error.

IMPORTANT NOTE: always prefer to program the parameters directly in the relay or through the memory card, as described in this manual, for safety. This protocol is accessible mainly because it allows you to read up to 250 target and air temperature readings. The part related to writing data is operational but should be avoided due to the possibility of programming errors and the possibility of even overwriting important data and rendering the relay inoperative, requiring factory maintenance. Therefore, either do not use the programming function by this method or use it with extreme caution.

It is more practical and simple to obtain temperature data, etc., using the TCP/IP Protocol, described above, where all Modbus over Ethernet communication can be implemented and all internal data from the Zyggot Raddia Relay can be obtained, in addition to writing all parameters. However, it is possible to use the ASCII Over TCP/IP protocol to obtain temperature data from the sensors, but the user will be required to convert each 2 ASCII Bytes into an Integer word, to obtain the numerical values for the temperatures according to the corresponding table at the end of this manual. In the same way, all alarm and trip levels for each sensor can be transferred at once, up to 125 sensors, plus two more alarm and trip levels for air temperatures. However, the user should also be responsible for transforming the data from 2-byte integer words into ASCII. However, we do not recommend this method due to the risk of incorrect programming and obtaining incorrect data.

Note that with a single parameter programming on a relay, the identical programming can be replicated on other relays using the memory card.



M13I-ETHERNET NTP PROTOCOL

This screen refers to the Ethernet Network Time Protocol, through which devices can obtain exact time data from previously established servers.

M13I.1 to M13I.7 - List of pre-established servers.

TESTING THE ETHERNET CONNECTION

USING A WINDOWS COMPUTER

A simplified way to test the **ETHERNET** connection is described below, using a simple executable software provided by Varixx (or using the **ZYGOT Thermography Supervisory 2.00** software (see the end of this manual), also provided free of charge by Varixx, or any similar program found on the world wide web). We will consider here the explanation using the executable **pyModbusTCPV5**

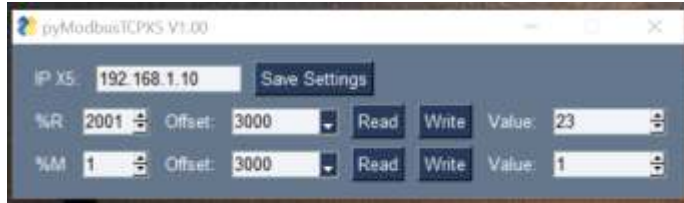

1- Initially connect the appropriate RJ45 cable between the computer and the LAN port of the **Zyggot Raddia** relay and open Windows Settings and select the Network and Internet option, which will open the properties screen that will contain content as below, among others.



2- Click on the "Change adapter options" option. The following screen will open, in which an unidentified Ethernet connection should appear, in addition to the other existing connections.



3- Right-click on the unidentified Ethernet connection. The following screen will open.

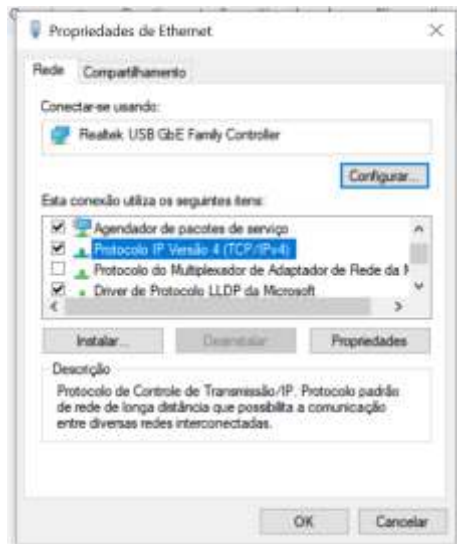

4- De um duplo clique na opção Protocolo IP Versão 4 (TCP/IPv4). Abrirá a seguinte tela.



4- Enter an IP address that is different from your local network, for example, if your network is **192.168.0.1** and press **OK**, you must use a network that has a different third digit. For example, we use **192.168.1.11** and in the **pyModbusTCPV5** program we use **192.168.1.10**, so the computer's address on the network will end in 11 and the Zyggot Raddia relay will end in 10. At this point, the two devices should already be connected and exchanging data. On the Zyggot relay, on the Menu screen, choose option **16. REPORT** and then the **ETHERNET REPORT / STATUS** option. Then go to screen ER3 and activate the **START** option to test the connection with PING.



If the connection is OK, it will indicate a response time in the **PING RESPONSE TIME** field, which should be around 0.01 mS. If the connection is not OK, it will indicate **PING TIMEOUT** and the **PING RESPONSE TIME** field will be all ++++++.

If the connection is OK, open the executable program **pyModbusTCPV5** and enter the chosen address, in this example **192.168.1.10**, and click Save Settings. Choose a register to be read, for example **%R2001**, which will contain the target temperature of Sensor 1, plus the necessary offset according to the Modbus tables in this manual, and click Read. The current temperature should appear in the Value field. In the same way, you can read flags of the **%M** type.



Attention: You can also write to the registers, but avoid this if you do not know that a particular register can be overwritten, as it may change the configuration parameters of the Zyggot Raddia relay.

OPERATION

IDENTIFICATION SCREEN



When energized, the relay will display the identification screen above and then perform a self-test, the results of which can be seen in the reports under the item «System Data». Then, if the Start of Operation has already been commanded (See next page), the relay will display the initial screen below, the first of 3 that can be paged through using the >> and << keys. These same screens can be accessed at any time from the Main Menu, using the «Esc» key.

TELAS DE INFORMAÇÕES



The first information screen, above, shows the system identification, embedded software version, date and time of the internal real-time clock, communication status with the S. Comm OK or S. Comm Error sensors and some indications at the bottom that are repeated on several screens to facilitate the overview of the Alarm and Trip system, namely: FAIL, which will be filled in red if there is an active fault, TRGT which will be filled in white if there is a fault related to the target temperature, AIR, which will be filled in white if there is a fault related to the air temperature (sensor body), ALRM which will be filled in yellow if there is an active alarm output and TRIP which will be filled in red if there is an active Trip output.

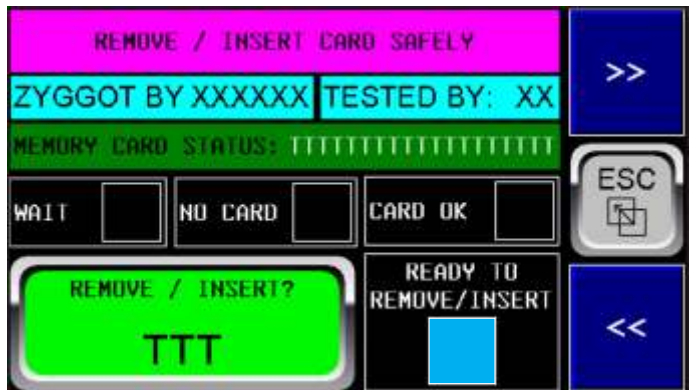
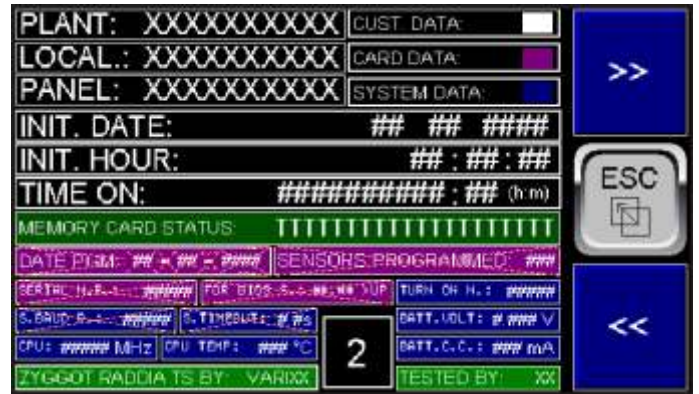

INFO screens 1 to 5 show system data and commands for inserting and removing the memory card safely, as previously described in the Main Screens section.

OPERATION

Normal Operation:

The operation is completely intuitive and can be easily learned in a matter of minutes.

It is understood that the sensors are already fully addressed by the program on the PC and correctly connected to the network as described elsewhere in this manual.

1- When the system is powered on, the start-up confirmation screen will appear only once, where the user confirms this by pressing the **Proceed** button, with the «Yes» option, and the Time ON counter will start.



2- After the procedure in item 1 or when the system is powered on, the main screen 1 (MS1) will appear a second time and the >> and << keys can be used to navigate through the 9 main screens (MS1 to MS9), as already described. Pressing «ESC» takes you to the Main menu (below).

Before operating or activating the system, have the parameter values and options you wish to enter in the Programming menu at hand and carry out all the programming, without permanently connecting the Alarm, Trip or Auxiliary outputs to avoid an inadvertent tripping of the system.

The first thing to do in the first operation is to check whether all the sensors are flashing correctly and responding. You can also command the «Flash» of all of them at the same time or one at a time to check addresses and whether they are active on the network. This is done using the Flash key in the Main Menu below.



3- This menu allows you to access all the system screens, in addition to the Programming Menu.

Pressing «ESC» on this screen displays the first System Information screen (below) and you can navigate through the 5 screens using the keys described above, such as >> and <<. The «ESC» key returns you to the Main Menu above.

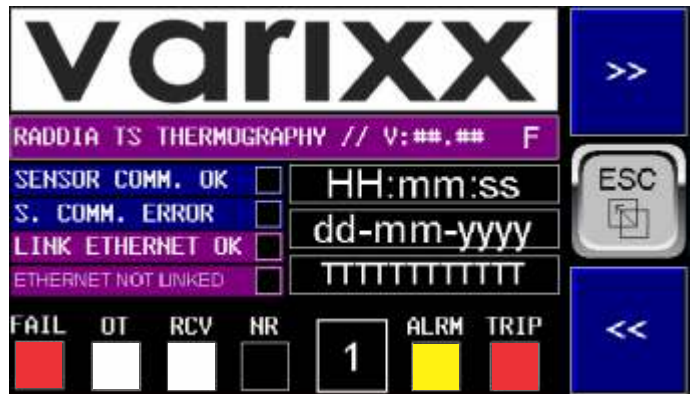

4- Using the corresponding keys, access all the Sub screens of each resource and interact or enter values on each screen, if necessary, as described in the Main Screens for Operation section, previously.

5- Note that the «Alarm» key may or may not have a flashing red outline. If it does, press it and enter the ALARM screen to acknowledge and eventually clear the fault indications.

6- Note that the relay can optionally be connected to the user's DCS system via a Modbus port as described. However, this connection is not necessary for the system to be fully protected.

SCREEN FLOW

INFO SCREENS

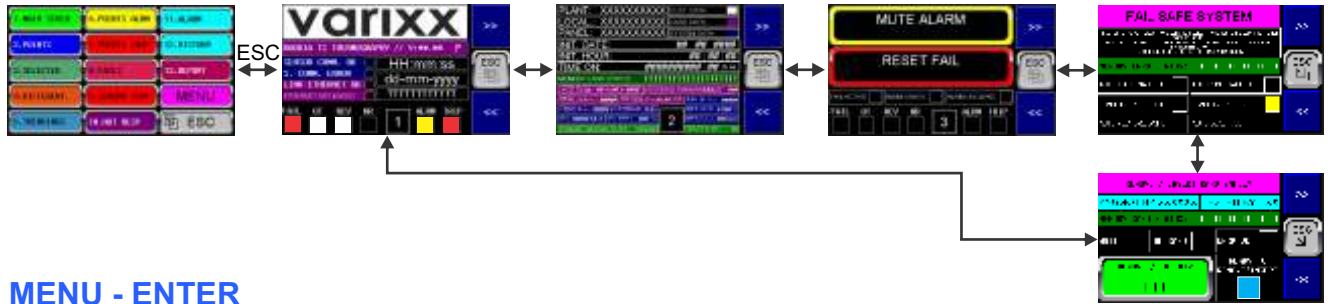

MENU - ENTER



1. MAIN SCREEN

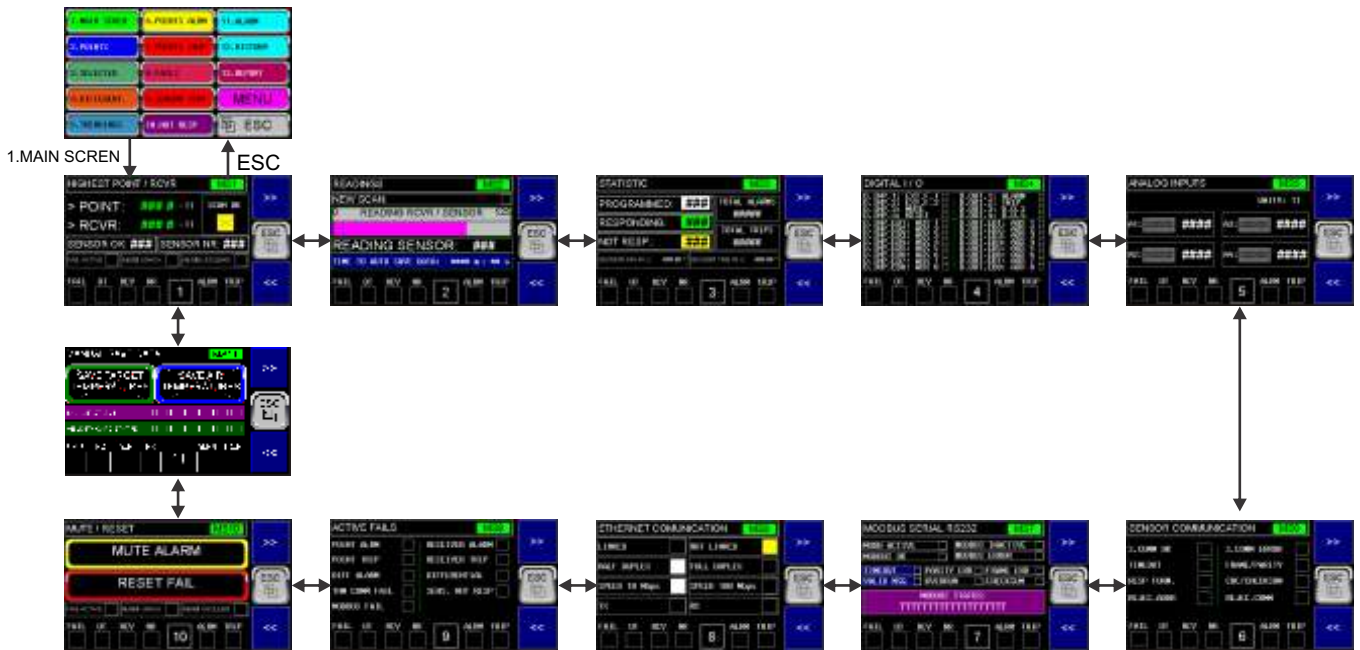

2. POINT

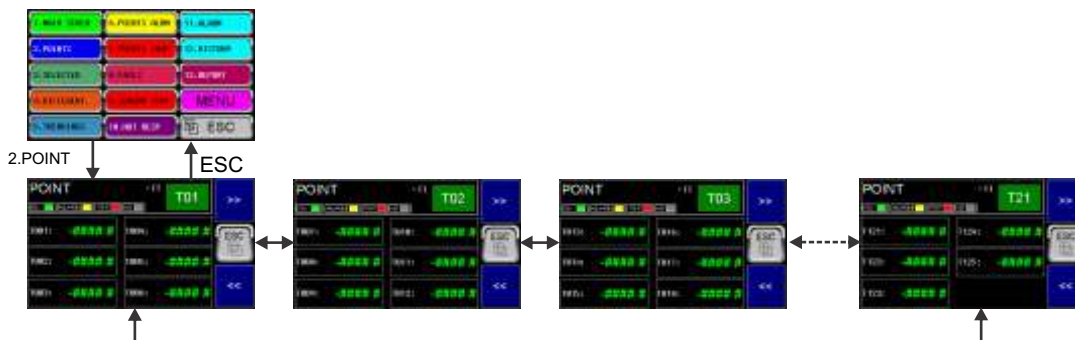

SCREEN FLOW

3.SELECTED



4.SELECTED



ESC



8.FAILS



5.FAILS



ESC



SCREEN FLOW

5. TRENDS

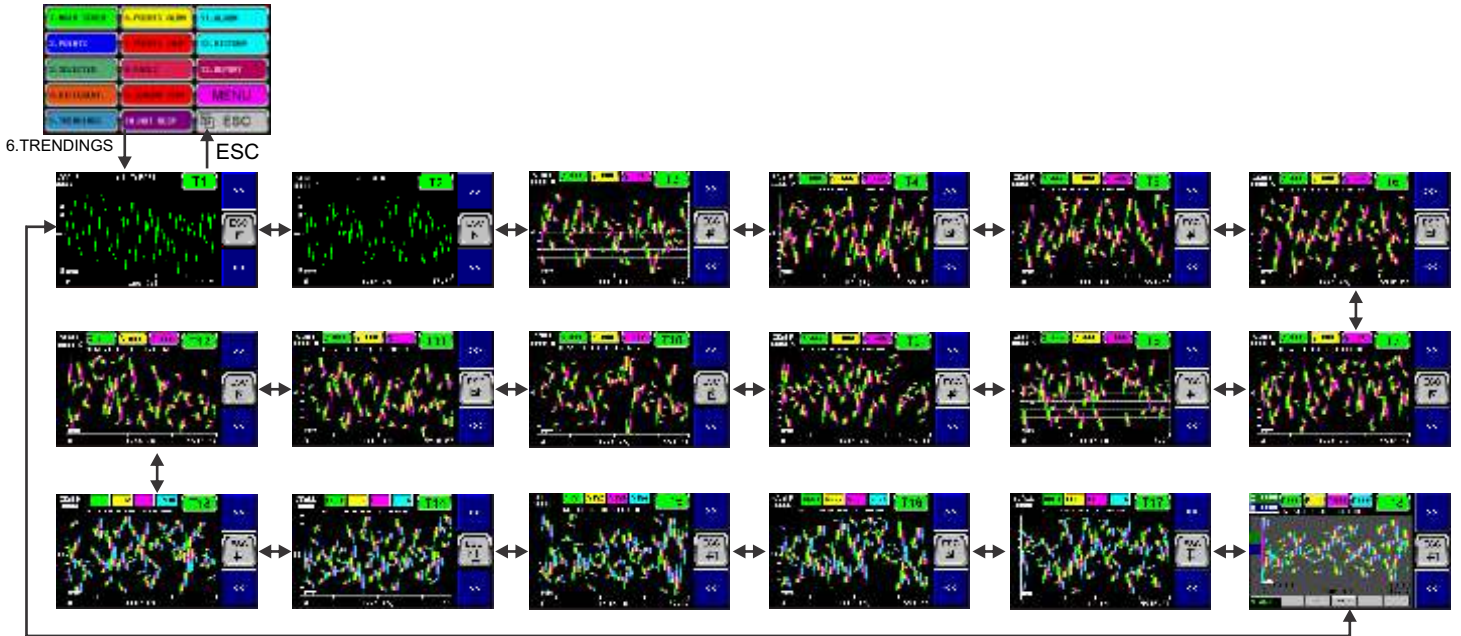

6. POINT ALARMS

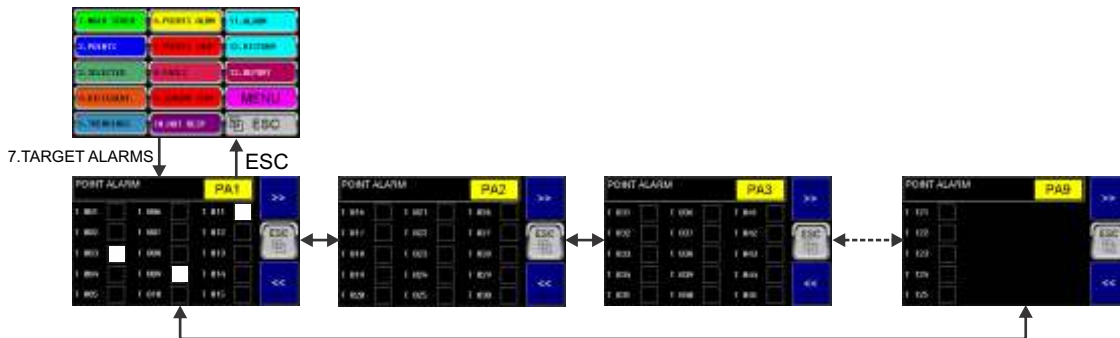

7. POINT TRIPS

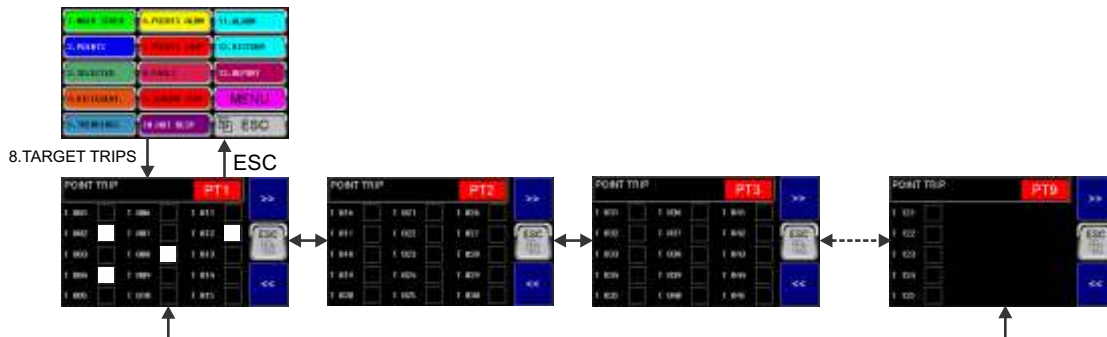

SCREEN FLOW

10. NOT RESPONDING

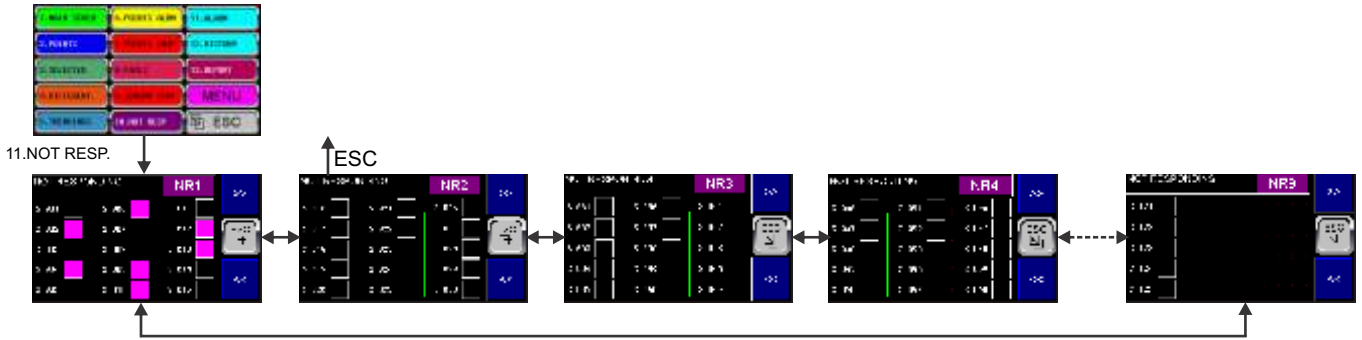

9. SENSOR STAT

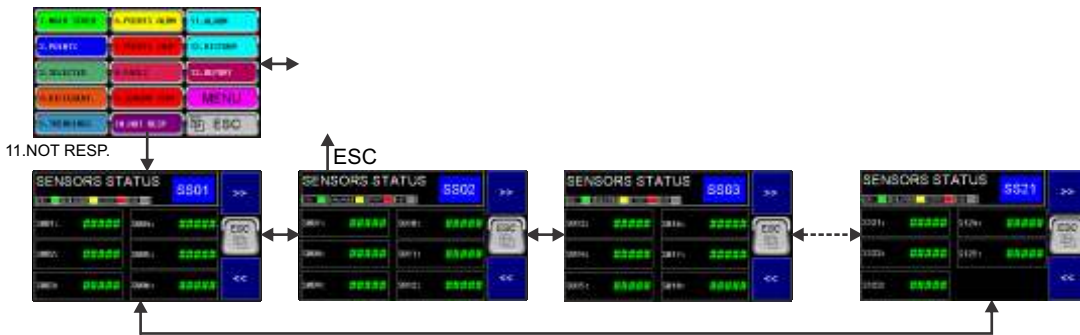

13. REPORT / CHECK RECEIVER DATA

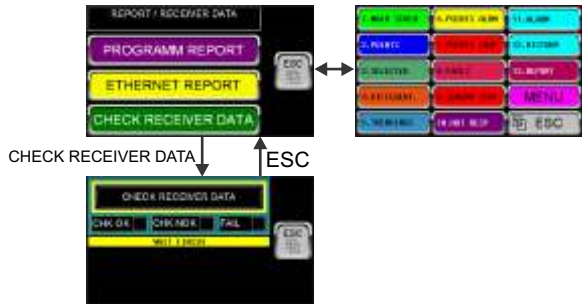

SCREEN FLOW

4. DIFFERENTIAL

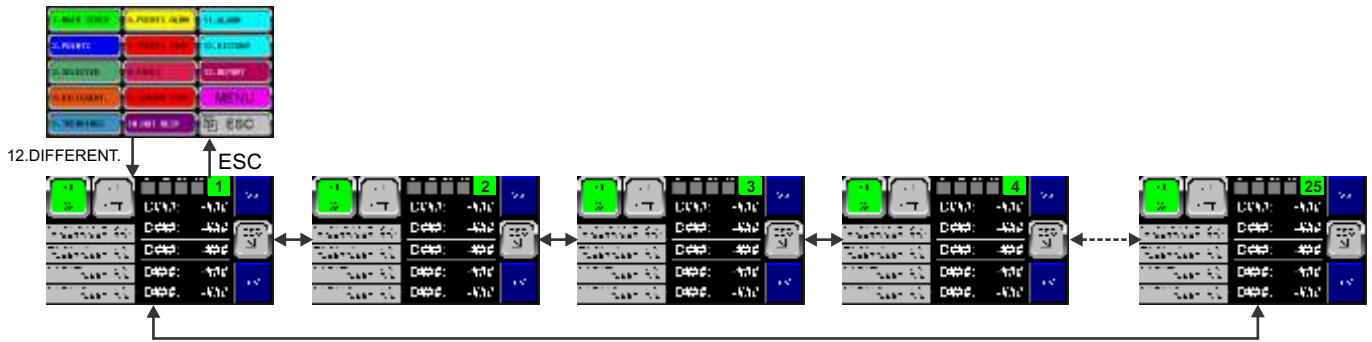

11. ALARM



12. HISTORY

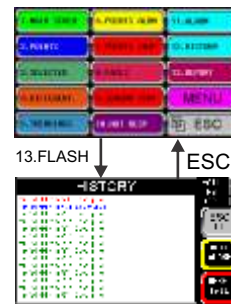

14. MENU / IDENT PROG.

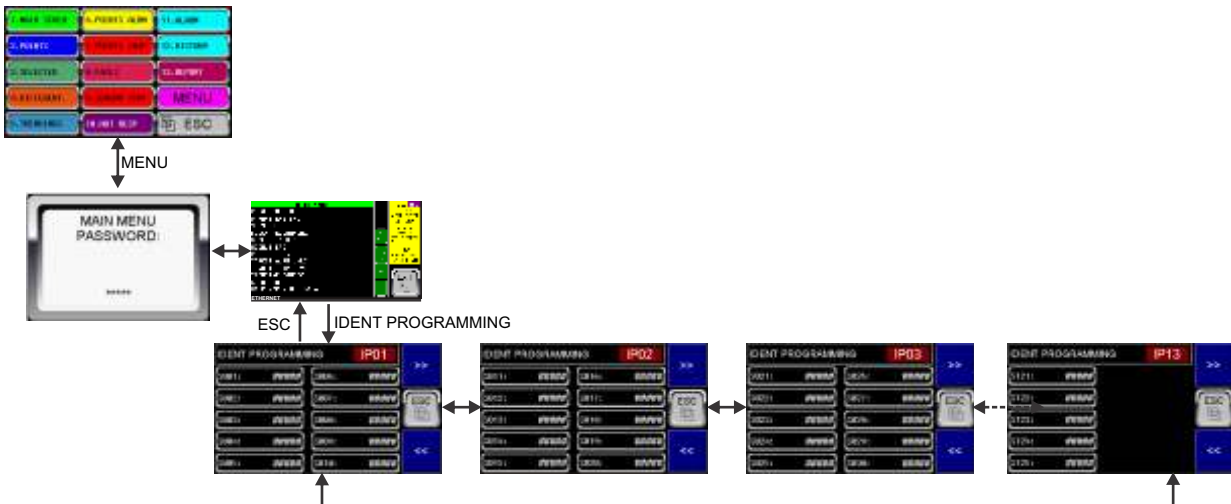

1/2 PROGRAM REPORT



PROGRAM REPORT

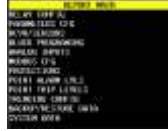

ETHERNET REPORT / STATUS
(see other page)

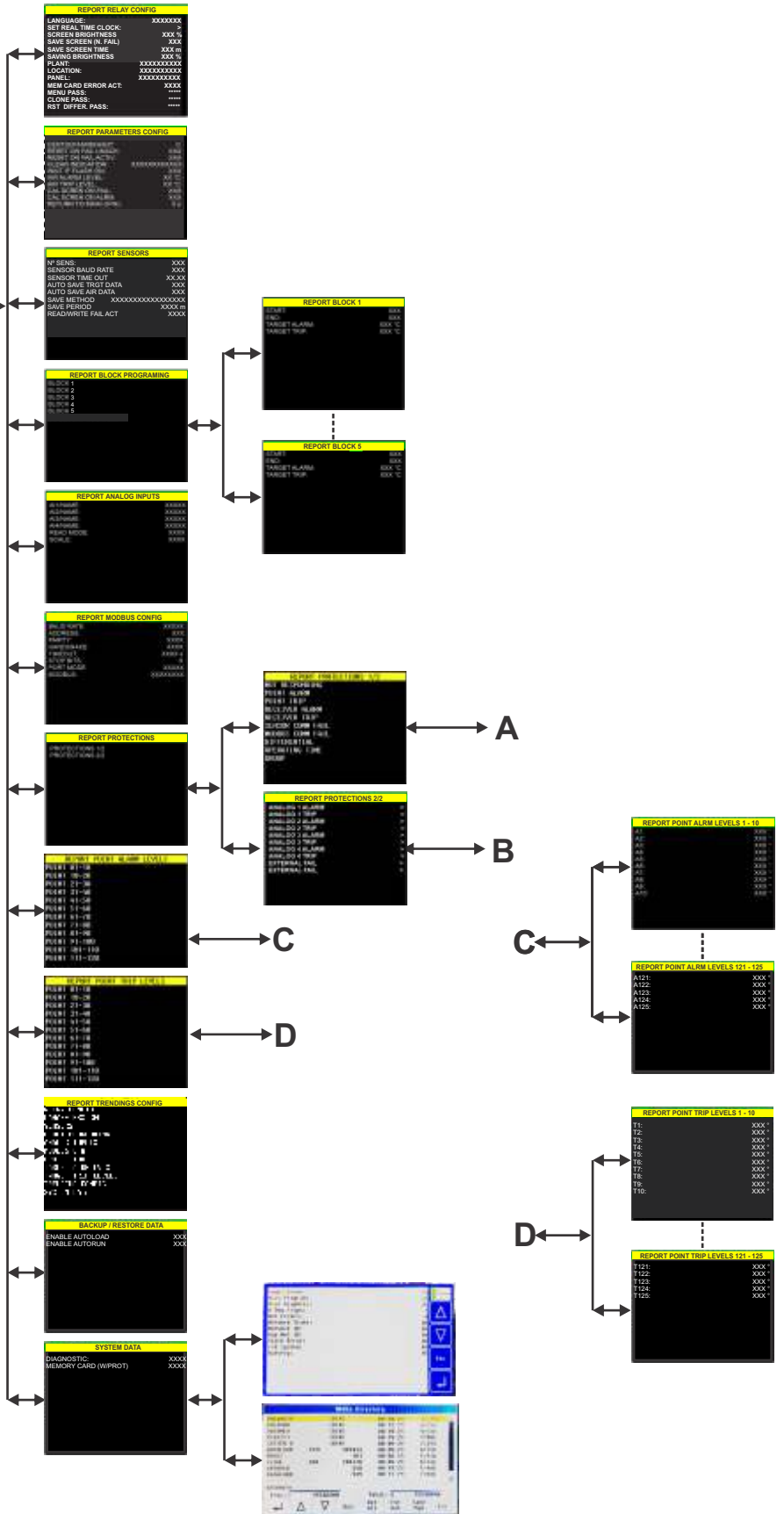

2/2 PROGRAM REPORT

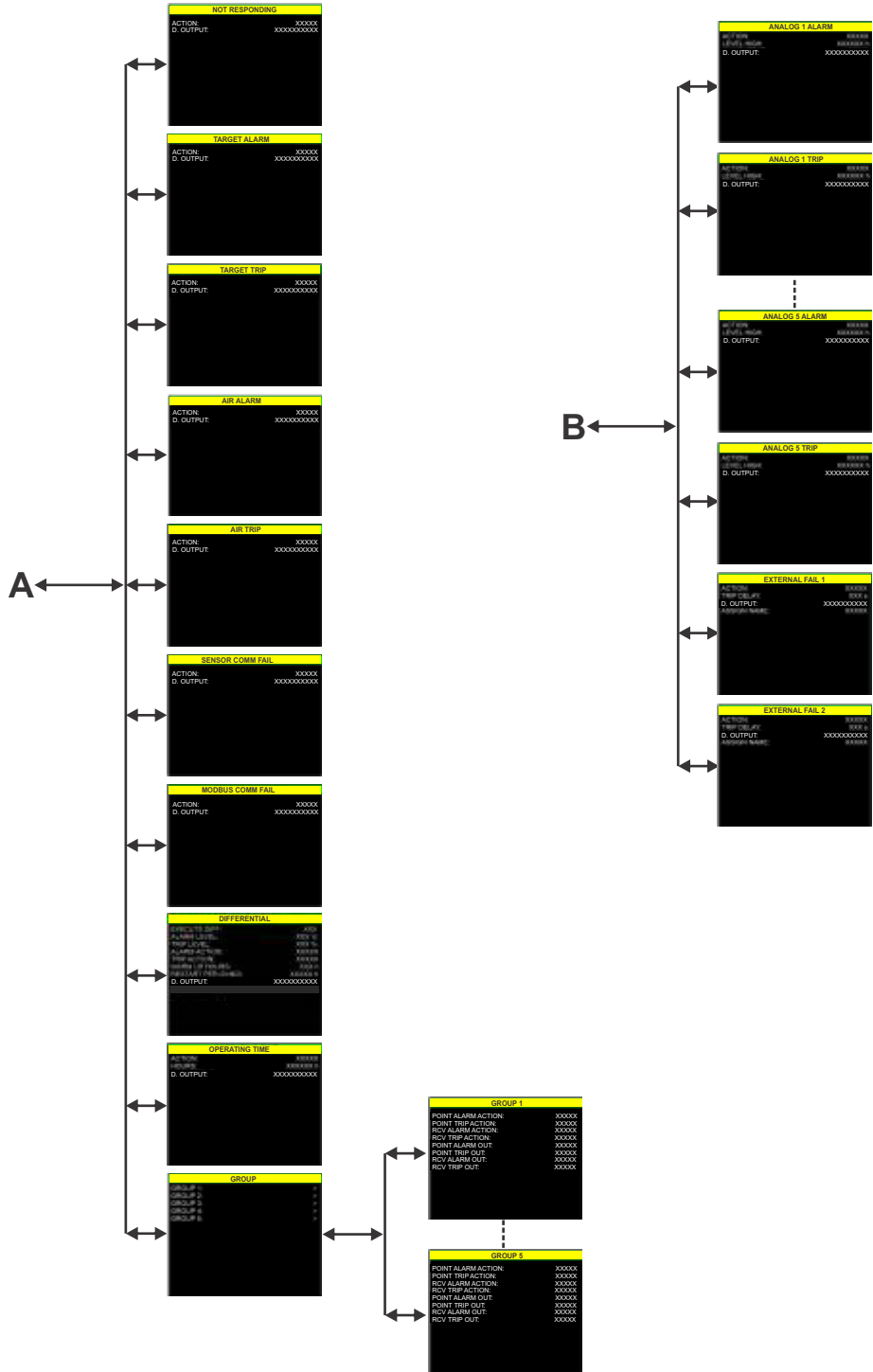

1/1 ETHERNET REPORT



PROGRAMMING MENU

PROGRAMMING MENU 2/2

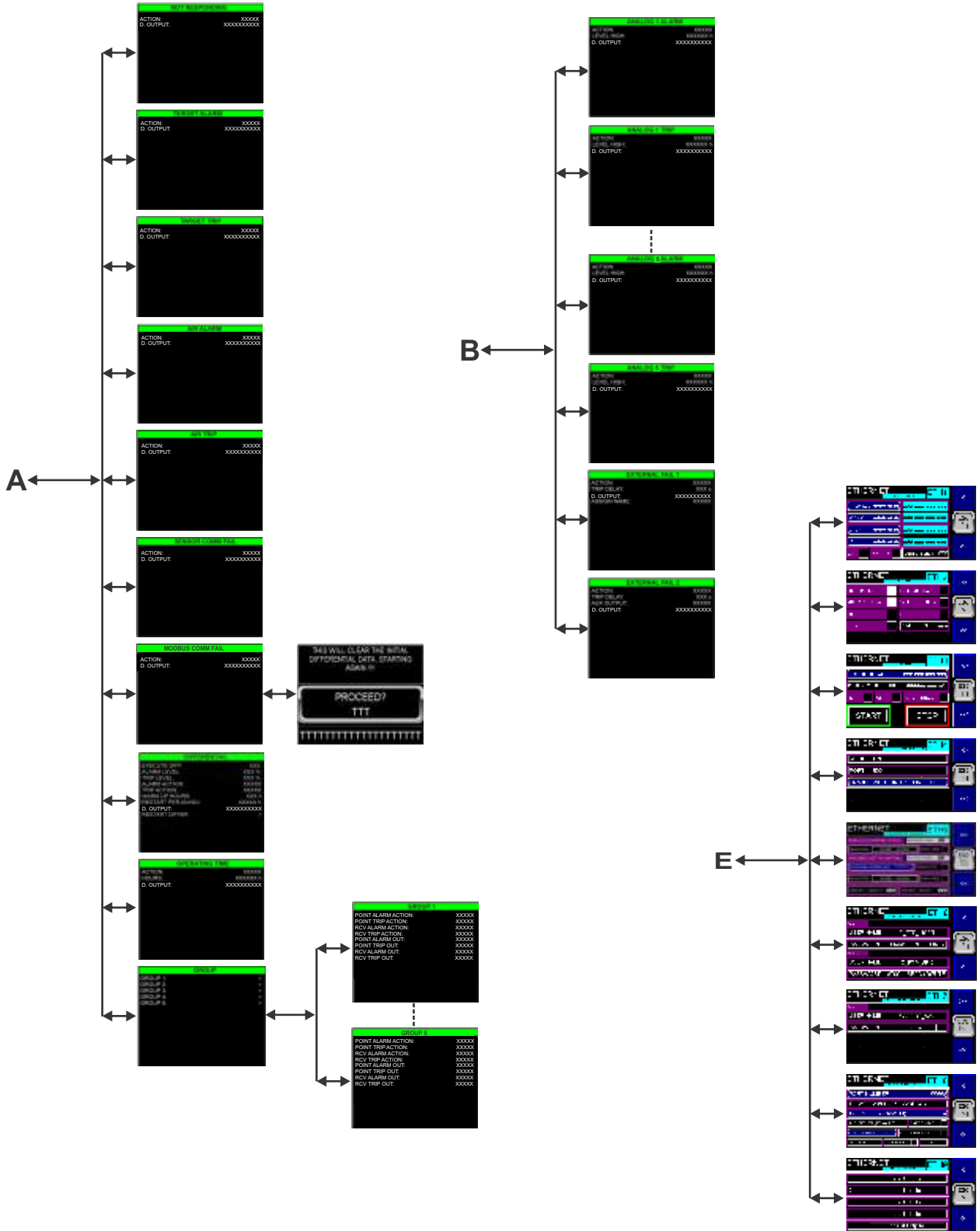

COMPUTER PARAMETERIZATION

ZYGOT SUPERGER

Zygot Superger is a configuration software for the Zygot family. The software is available free of charge on the Varixx website (<http://www.varixx.com.br>). The main screen of the program is shown on the side.

It is possible to configure the relay directly on the relay itself and also to perform the complete programming on a relay and to clone this relay to several others using a memory card or pendrive, as explained previously. install the Superger Software on the Windows computer. All the files necessary to run it, including the «Runtime» files, are already included in the package, so no additional software is required. Once installed, it will be ready to run.



Note: With Zygot Superger you can easily clone the parameters of one relay to another (this can also be done via the uSD card). To program a series of relays with the same parameters, simply save them (using the «Save» button in the Superger software) and load the file later if necessary so that all the parameters are ready to «Send» to the relay.

1- The first step is to connect the relay. To do so, adjust the Modbus communication values on the relay and activate it in RS-232 mode. For details on how to activate Modbus, see the programming menu section. Use an RS-232 / RJ45 cable to connect the relay to a computer. You can also use the Ethernet port and do all the programming via Ethernet communication. In this case, program the correct address as programmed on the relay in the Ethernet programming section (Modbus TCP/IP).



2- The next step in the software is to choose the language and working mode on the system configuration screen:

Once you have chosen the language, choose the Zygot VZX or Zygot V5FTA or Zygot RADDIA TS system relay. Once you have chosen the language and the type of relay, by clicking on its image, select the correct parameters for your computer (COM port 1, COM2, etc.) and the parameters that were programmed on the screen regarding Modbus in the relay (For example: Address: 1, Baudrate: **19200**, Timeout: **1000 mS**, **Parity**: None or in the case of Ethernet communication the IP Address, for example: **192.168.1.1**)

Make sure that Modbus is in the «Active» condition in the relay. Normally, once any parameters related to Modbus in the relay have been changed, it is necessary to turn the relay off and on again for the changes to take effect, as these are parameters related to the relay BIOS.



ZYGOT SUPERGER

3- Once the parameters are correct and the relay has Modbus enabled, click on «Connect». The «**Connected**» indicator should light up and the current parameter reading bar will indicate that the parameters are being read on the relay. This is because you can save them and also indicate in red in each parameter window that is changed that the respective parameter will be changed if you use the «**Save**» key. You can also use the «**Receive**» key at any time to read the current parameters again. The window on the right shows all the LOG messages to facilitate any communication corrections.

5- You are ready to program all parameters in the subsequent screens. Note that in each available window, when a parameter is changed, it turns red as a warning that it will be changed when sending the data to the relay.



4- When the connection is made, the connected light will light up. If the initial reading box is checked, immediately after connecting to the relay, all the relay parameters will be transferred to the program. When finished, a success message will be displayed. Use the save and open buttons to save the information from a relay to a file on the computer and download the same information to other Zygot relays.

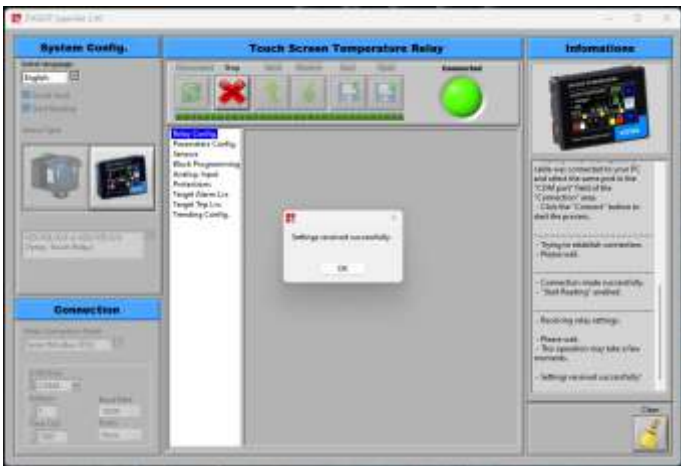

COMPUTER PARAMETERIZATION

ZYGGOT SUPERGER

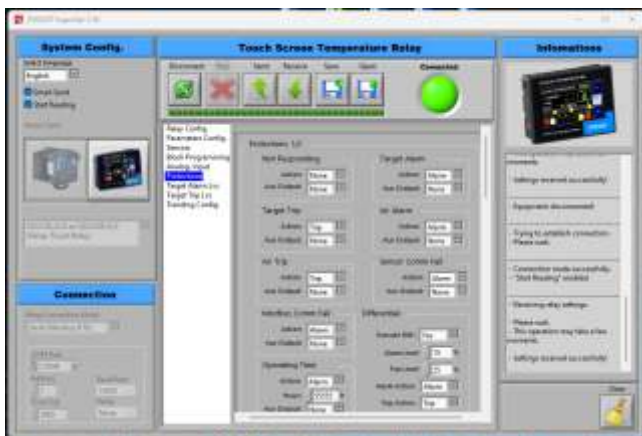

COMPUTER PARAMETERIZATION

ZYGGOT SUPERGER

6- Once the parameters are correctly programmed, they can be saved to a disk file for later use using the «**Save**» button. Previously saved files can also be loaded using the «**Receive**» button.

To send new data to the relay, use the «**Send**» button and at any time, the current relay parameters can be loaded using the «**Receive**» button.

When sending data to the relay, at the end of the transmission, a screen appears confirming that the data was transmitted successfully.

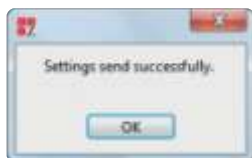

SETTINGS

ZYGGOT MANAGEMENT SOFTWARE

Zyggot Manager is a configuration software that performs the addressing and testing of sensors. The software is available free of charge through the Varixx website <http://www.varixx.com> or <http://www.varixx.com.br>.

Install the software on your Windows computer. All the files needed to run it, including the “Runtime” files, are already included in the package, so no additional software is required. Once installed, it will be ready to run.

The program allows you to check and define important parameters before using the sensor on the network.

It defines the sensor address, the emissivity of the target considered by the sensor and the distance between the sensor and the target.

The user-friendly interface allows you to view the temperature of the target and the sensor body in several ways:

- >> Through a graph, you can check the temperature measured over time. The scale ends can be changed with a mouse click.
- >> Temperature readings are also indicated in numerical form.

- >> Through an “analog” marker. The full scale value can be changed.

You can also send a command to make the sensor LED blink. Unlike when connected to the relay, the sensor remains on and does not blink when connected to the computer.

Software Manager Main Window

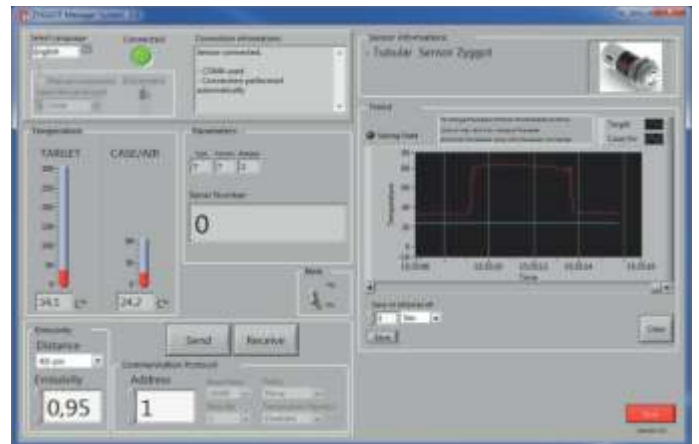

! CAUTION !

Do not connect the sensor to the PC while the other mini USB port is connected to the network.

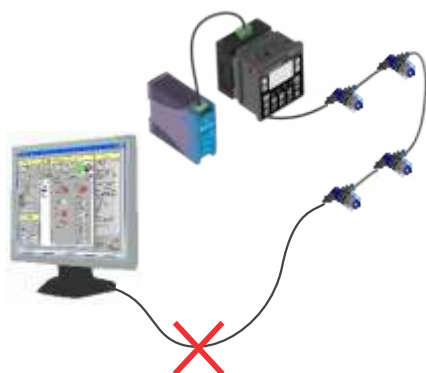

FAIL SAFE SYSTEM

The Fail Safe System is a feature that allows the Zyggot relay to continue operating in the event of certain types of "soft" failures. These "soft" failures include:

- Loss of backup battery power.
- Corruption of the register RAM, or corruption of the firmware Flash due to, for example, an excessive EMI event.

| Nome | Data de modificação | Tipo | Tamanho |
|----------------|---------------------|-------------------|---------|
| ■ PLOTZ21 | 17/08/2021 09:09 | Pasta de arquivos | |
| ■ DATANEW | 18/08/2021 16:53 | Pasta de arquivos | |
| ■ DATAMAN | 12/08/2021 16:27 | Pasta de arquivos | |
| ■ DATAAUTO | 12/08/2021 10:38 | Pasta de arquivos | |
| ■ DEFAULT.PGM | 09/08/2021 18:32 | Arquivo PGM | 482 KB |
| ■ AUTOLOAD.PGM | 09/08/2021 18:33 | Arquivo PGM | 482 KB |
| ■ CLONE.DAT | 09/08/2021 18:33 | Arquivo DAT | 107 KB |
| ■ DATACARD | 17/08/2021 19:06 | Arquivo | 1 KB |
| ■ DATABACK | 18/08/2021 09:51 | Arquivo | 1 KB |
| ■ BACKZ | 06/08/2021 17:47 | Arquivo | 1 KB |

The Fail Safe System must have a file structure on the Memory Card similar to the one shown in the screen above.

Attention: With the exception of files within directories, which can be freely changed or deleted, files in the root directories cannot be modified or deleted, as this will interrupt the relay's operation.

The failsafe system encompasses the following features:

- Manually back up current registry settings from battery-backed RAM to Flash memory.
 - Manually restore registry settings from previously saved values in Flash to battery-backed RAM.
 - Detect corrupted registry settings at boot and then automatically restore them from Flash memory.
 - Detect corrupted or empty Firmware in Flash memory at boot and then automatically load the AUTOLOAD.PGM file from removable media (Compact Flash or microSD).
 - If an automatic registry restore or application load occurs, the Zyggot Raddia will automatically be put into RUN mode.
- The failsafe system can optionally be supplied ready-made and configured by Varixx.

HOW TO DO...

HOW TO PROGRAM THE RELAY.

There are three ways: Using the HMI itself, or using the free PC configuration program, or using the Backup/Clone function from a memory card. To use the PC program, see the specific manual.

To program using the HMI:

Press «Menu», enter the correct password and follow the user-friendly submenus.

If the programming password is Zero, you will enter the menu directly; if it is different from zero, a screen will appear asking for the password. Enter it and press ENTER

You can change this password in the Param. Config. menu. The factory password is 1.

To program using the PC software, see the specific manual for the software.

To clone data using a memory card, use option 12. Backup/Clone in the Main menu.

Backup the data of a previously programmed relay using the «Backup» function

For a relay without programming, use the «Restore» function in this menu.

HOW TO CHOOSE THE LANGUAGE.

For the screens and menus, the relay is available in 3 languages: English, Portuguese and Spanish. Any fourth language can be requested at the time of purchase (Custom) by prior agreement with the manufacturer.

To select the language:

Enter the Menu, Relay Configuration Submenu,

Select the Language item,

Press Enter,

Select the required language by pressing Enter again to confirm and ESC to exit the menu.

HOW TO CHANGE THE PROGRAMMING PASSWORD (“RELAY CONFIG” MENU).

! Enter the Main Menu and then the Relay Config submenu.

! Choose the item to change and press ENTER.

! Menu Pass: Enter the new password if you wish to change it. The factory password is 1. If you enter “0” as the new password, you can enter the Menu without a password by simply pressing the Menu key.

! Press ENTER to confirm.

HOW TO NAME THE PLANT, LOCATION AND PANEL AND ENTER THE START DATE OF OPERATION.

For information purposes, the above items can be named with up to 5 characters. Proceed as follows:

Enter Menu, Relay Config Submenu,

Select the desired item,

Press Enter, Enter the new data using the numeric keys, press Enter to confirm and ESC to exit the menu.

HOW TO CHECK FOR NON-RESPONDING SENSORS.

To view the map of non-responsive sensors, press 10.NOT REP. to call up the NR1 screen and use the arrows to view all NR screens if necessary. Non-responsive sensors will be marked with purple squares.

If there is no response during a reading attempt, the indication on the main screen will be activated and all indicators of non-responsive sensors on screens NR1 to NR9 will be activated, since there was no response. In this case, all temperature readings will be indicated with 8888, as invalid. In this case, there will be no trip or alarm due to temperature, but only due to Not Responding if it is enabled.

HOW TO SET THE REAL TIME CLOCK.

If necessary, due to daylight saving time or other reason, proceed as follows:

Enter Menu, Relay Config Submenu, Select the Set Real Time Clock item, Press Enter, Enter the new data, using the small arrows below the display, press Enter to confirm and ESC to exit the menu.

HOW TO SET PARAMETERS (“PARAMETERS” MENU).

! Enter the Main Menu and then the Config Parameters submenu.

! Choose the item to change and press ENTER,

! Choose the option in the list for each parameter or enter the data if it is numeric,

! Press ENTER to confirm,

! Choose the next item and repeat the operation.

HOW TO CONFIGURE MODBUS COMMUNICATION. (“MODBUS” MENU).

The names for this menu are the classic ones and there is nothing to explain, since the user must know the protocol to use Modbus communication. The port for Modbus communication is Rj1.

Enter the Programming Menu and then the Modbus CFG submenu.

Choose the item to change and press ENTER.

Choose the option from the list for each parameter or enter the data if it is numeric.

Press ENTER to confirm.

Choose the next item and repeat the operation.

The parameters are as follows:

Baud Rate, Address, Parity, Handshake, Timeout, Port Mode (RS232 or RS 245), Stop Bits and Modbus (Active, Inactive)

HOW TO CONFIGURE CURVES (TRENDING). ("CONFIG TRENDING" MENU).

The curves related to temperatures and analog inputs must be configured in this menu.

Enter the Main Menu and then the Config Trending submenu.

Choose the item to change and press ENTER

Choose the option from the list for each parameter or enter the data if it is numeric or alphanumeric.

Press ENTER to confirm.

Choose the next item and repeat the operation.

The parameters are as follows:

Scale: Enter the scale to be used for all curves.

Index Mode: (Display, Menu). If Display is selected, the operator must enter the indexes for each curve directly on the curve screens as explained in the Operation chapter. If Menu is selected, the indexes used will be those entered below.

HMI Reset: (No, Yes). Enables or disables the possibility for the operator to reset or restart each curve using the ESC command (to do this, hold down the ESC key for 3 seconds and the curve will restart).

Index 1A-5A to Index 6C-10C. (1 to 129): enter the sensor numbers from 1 to 125.

These are the signals that will be used in the corresponding curves if the Menu mode is selected in Index Mode. The curves of indexes 1 to 5 (A, B and C, i.e. three curves per trending screen) will be shown on trending screens 3 to 7 and the curves of indexes 6 to 10 will be shown on screens 8 to 12.

For the T18 screen, which is retentive and can save the time and date curves in Excel format on the memory card, select the Enable Retentive item and choose «Yes».

See more details in the Programming chapter.

HOW TO SET TARGET OVERTEMPERATURE ALARM LEVELS. ("TARGET ALRM LEVELS" MENU).

Target alarm levels can be defined in block programming, as already explained. You can program a single group with all sensors if the level is the same for all or up to 5 different levels, one for each block. Another way, even after performing block programming and if you want to individually change some or all of the levels, is through the "Target Alarm Levels" menu.

Access the Main Menu and then the Target Alarm Levels submenu.

A menu with 13 submenus will be displayed, each containing up to 10 levels.

Select the level to change and enter the value.

Press ENTER to confirm,

Select the next item and repeat the operation.

HOW TO CONFIGURE ANALOG INPUTS. (MENU "ANALOG INPUT").

For analog inputs, you can enter the name of each one (5 characters), making identification easier, choose the reading mode and scale.

Go to the Main Menu and then to the Analog Input submenu.

Choose the item to change and press ENTER.

Choose the option from the list for each parameter or enter the data if it is numeric or alphanumeric.

Press ENTER to confirm.

Choose the next item and repeat the operation.

HOW TO SET TARGET OVERTEMPERATURE ALARM LEVELS. ("TARGET TRIP LEVELS" MENU).

Target trip levels can be defined in block programming, as already explained. You can program a single group with all sensors if the level is the same for all or up to 5 different levels, one for each block. Another way, even after performing block programming and if you want to individually change some or all of the levels, is through the "Target Trip Levels" menu.

Access the Main Menu and then the Target Trip Levels submenu.

A menu with 13 submenus will be displayed, each containing up to 10 levels.

Select the level to change and enter the value.

Press ENTER to confirm,

Select the next item and repeat the operation.

HOW TO DEFINE THE ACTIONS AND AUXILIARY RELAYS ACTIVATED FOR EACH PROTECTION. ("PROTECTIONS" MENU).

The action to be taken, which can be: Nothing (disables the protection), Log (the event is entered in the history and alarm list but no output relay is activated (not even the Alarm relay or Trip relay), Alarm (the Alarm output relay is activated) and Trip (the "Alarm" and "Trip" outputs are activated).

There are 2 protection submenus: Protections 1/2 and Protections 2/2.

The first contains the general protections, the second the protections related to the analog inputs and external faults.

Enter the Main Menu and then the Protections submenu.

A menu with 3 submenus is displayed.

Select one of them and press ENTER.

Select the subitem of the protection to be programmed and press ENTER,

Select the action and auxiliary relay.

SUPERVISORY SOFTWARE

ZYGGOT THERMOGRAPHY 2.0 SUPERVISORY SOFTWARE

Zyggot Supervisory - Version 3.00 and higher, is a program that communicates with the relay and displays the sensor readings on the computer screen, similar to a supervisory system. The software is available free of charge through the Varixx website (<http://www.varixx.com.br>).

Install the software on your Windows computer. All the files needed to run it, including the "Runtime" files, are already included in the package, so no additional software is required. Once installed, it will be ready to run. Zyggot Supervisory - Version 3.00 and higher, is a program that communicates with the relay and displays the sensor readings on the computer screen, similar to a supervisory system. The software is available free of charge through the Varixx website (<http://www.varixx.com.br>).

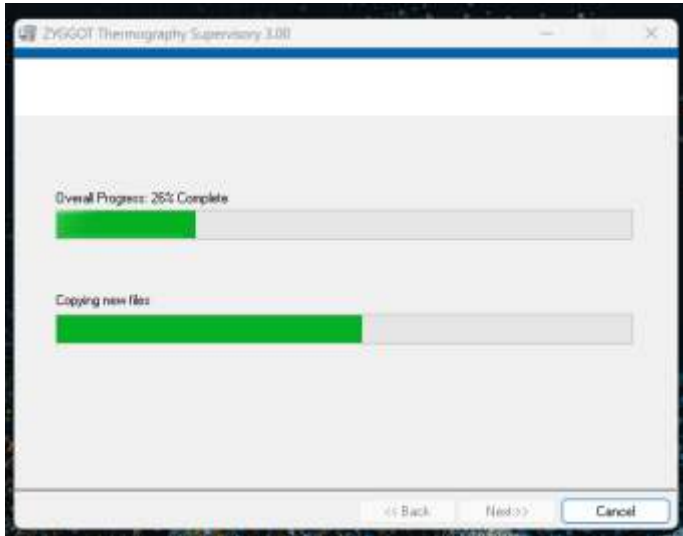

1- The first step is to connect the relay. To do so, adjust the Modbus communication values on the relay and activate it in RS-232 mode. For details on how to activate Modbus, see the programming menu section. Use an RS-232 / RJ45 cable to connect the relay to a computer. You can also use the Ethernet port and do all the programming via Ethernet communication. In this case, program the correct address as programmed on the relay in the Ethernet programming section (Modbus TCP/IP). Use an Ethernet cable in this mode.



Note: This software is not required for the system to operate. It is a bonus that the user can use to check the system or not.

2- The first step is to press the Configure Modbus button. You will see the initial «Configure Modbus» screen. Once you have chosen the connection mode, namely a) Modbus RTU (Serial) or b) Modbus TCP (Ethernet) (in the upper selection box, under the phrase «Select the communication medium») and entered the parameters corresponding to those entered in the relay, you can click the «Connect» button and if the connection occurs, the «Connected» flag will change from red to green.



3- Once connected, click on the «Overview 1» button or on the «Overview 2» button. In the case of the first screen, you can see the Target and Air (sensor body) Temperatures of each sensor responding on the network and a description of the same case inserted.

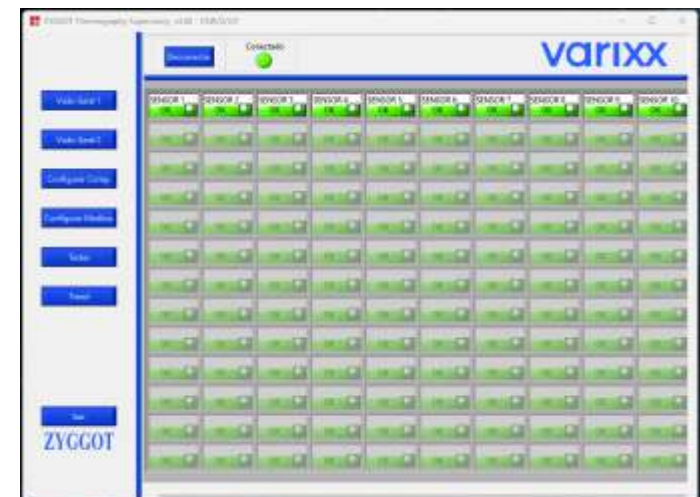

SUPERVISORY SOFTWARE

ZYGGOT THERMOGRAPHY 2.0 SUPERVISORY SOFTWARE

3- Once connected, click on the «Overview 1» button and you can see the target and air (sensor body) temperatures of each sensor responding on the network and a description of the same case inserted.

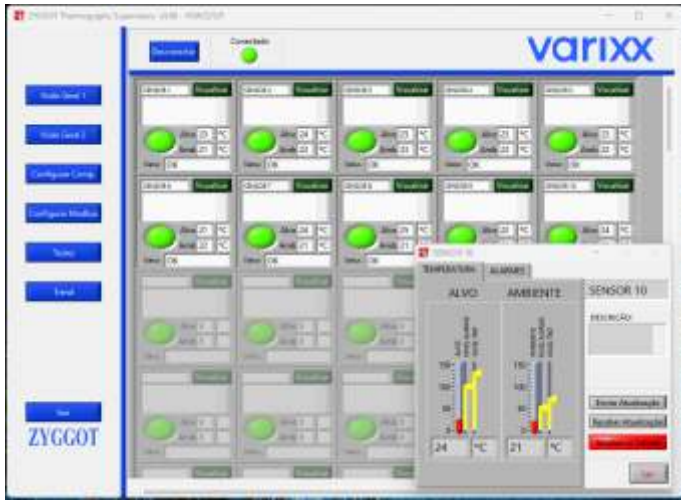

4- Click on the “View” button or on the lens symbol for each sensor. A window will open with alarm adjustment sliders and alarm and trip level parameters, which can be adjusted with the mouse and sent to the relay by clicking on the “Send update” button. Note that when changing the slide, the color of the slide changes from blue to yellow until the “Update” command is given. This function is also used to test the alarm or trip action by adjusting the levels below the current reading levels indicated in red. By clicking on the “Alarms” tab in this window for each sensor, you can also change the alarm and trip levels in the corresponding windows, using the mouse or by entering the values using the keyboard. Note that the color of the window changes to red until a possible “Send update” command is given. In this way, you can change relay parameters in real time.

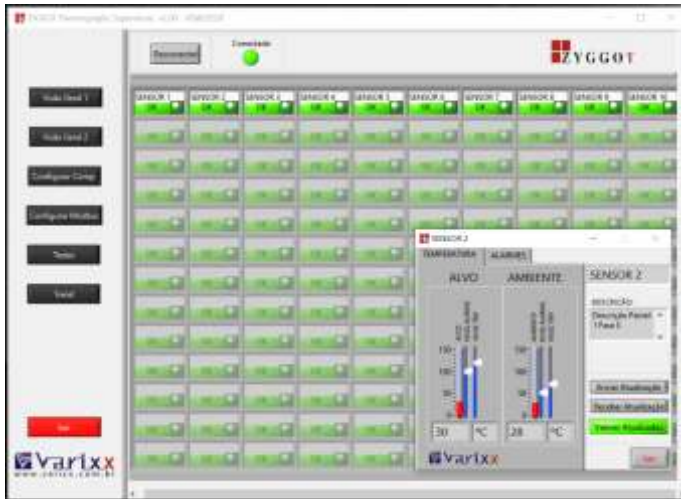

5- Click on the «Configure Comp» button in the left menu and the following screen will open with 3 options namely «Sensors», «Thermometers» and «Alarm Levels»



6- Click on the «Sensors» tab and you can enter a description of each of the sensors, for example «Column R» etc. Click on the Thermometers tab and you can change the scales of each thermometer in the graph. Click on the «Alarm Levels» tab and you can change the waiting time to be notified of a change in level.



7- Click on the “Tests” tab and you can change the blinking mode of the LED on each sensor, from blinking to continuous or vice-versa, to locate it on the panel or to test whether it is responding correctly on the network. Zero controls the change in all sensors.



SUPERVISORY SOFTWARE

ZYGGOT THERMOGRAPHY 2.0 SUPERVISORY SOFTWARE

8- Click on the «Trend» button and you will see the screen where you can plot the Target and Air temperatures of up to 10 sensors simultaneously. Through the corresponding windows you can choose the sensors to be plotted, whether Target and/or Air, and the color of the line for each one. To change the color, click on the small colored square of each line and choose the new color.

In the lower window on the left side you can choose the period for automatic saving of the readings in a CSV file, which can be opened in Excel. You can also command manual saving at any time by pressing the «Save» button.

Using the «Save» button you can save the data read so far in Excel CSV format, for later documentation, and you can even generate the corresponding graphs. Once you click on save, a window will appear to choose the destination and the name of the file.

In the last figure, below, you can see an example of a file, with 5 sensors and Target and Air temperatures of each one for each of the readings.

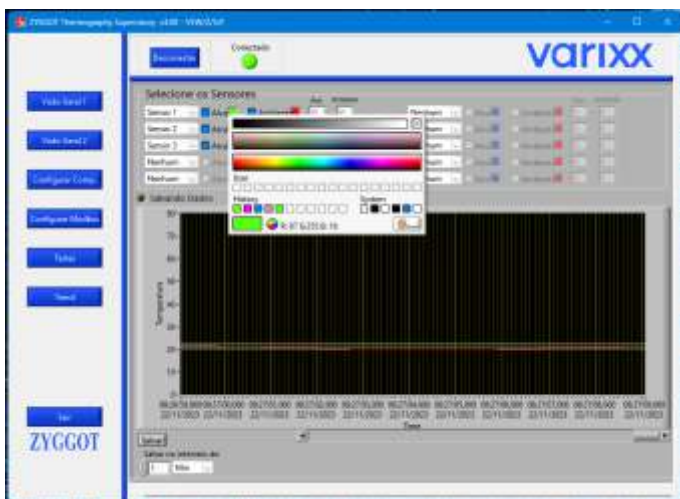
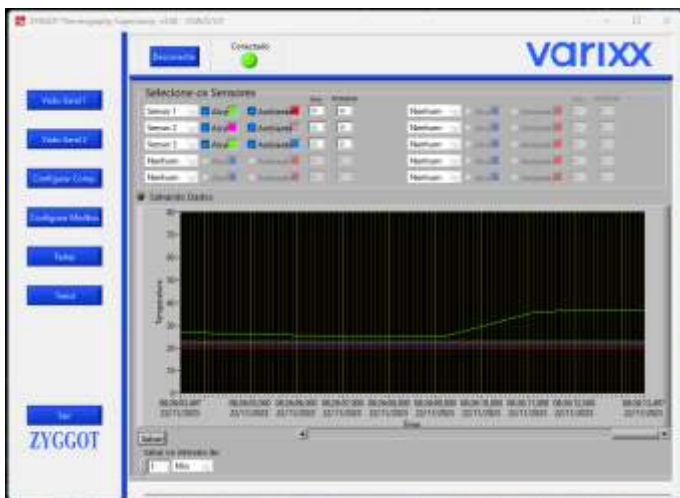
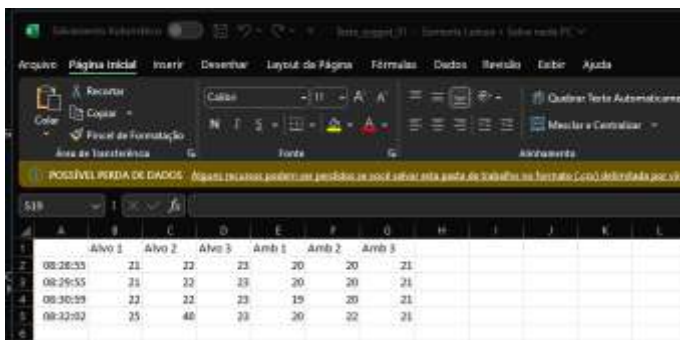
The screenshot shows an Excel spreadsheet with the following data:

| | Año 1 | Año 2 | Año 3 | Amb 1 | Amb 2 | Amb 3 |
|----------|-------|-------|-------|-------|-------|-------|
| 08:28:55 | 21 | 22 | 23 | 20 | 20 | 21 |
| 08:29:55 | 21 | 22 | 23 | 20 | 20 | 21 |
| 08:30:59 | 22 | 22 | 23 | 19 | 20 | 21 |
| 08:32:02 | 25 | 48 | 33 | 30 | 32 | 21 |

MODBUS

A complete explanation of the Modbus RTU or ASCII protocol is not within the scope of this manual. It is assumed that the user who will apply the same using this protocol, must have sufficient knowledge for this.

Also, in this manual we will only provide the basic addresses of the memory map to perform the usual operations of reading faults and others. Any parameter programming must be performed on the device itself, as it is normally done only once, during Startup.

Next, there will be a short introduction to the Modbus communication network before the memory map presentation.

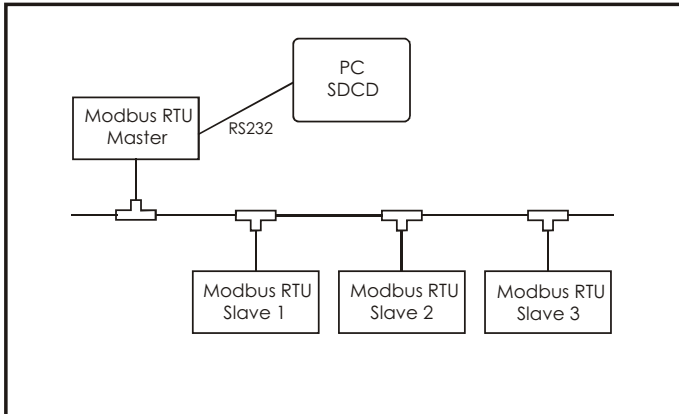

Devices communicate using a master-slave technique, in which only one device (the master) can initiate transactions (called 'queries'). The other devices (the slaves) respond by supplying the requested data to the master, or by taking the action requested in the query. Typical master devices include host processors and programming panels. Typical slaves include programmable controllers, motor controllers, load monitors etc, see Fig

The master can address individual slaves. Slaves return a message (called a 'response') to queries that are addressed to them individually. The Modbus protocol establishes the format for the master's query by placing into it the device address, a function code defining the requested action, any data to be sent, and an error checking field. The slave's response message is also constructed using Modbus protocol. It contains fields confirming the action taken, any data to be returned and an error-checking field. If an error occurred in receiving the message, or if the slave is unable to perform the requested action, the slave will construct an error message and send this as its response, see Fig.

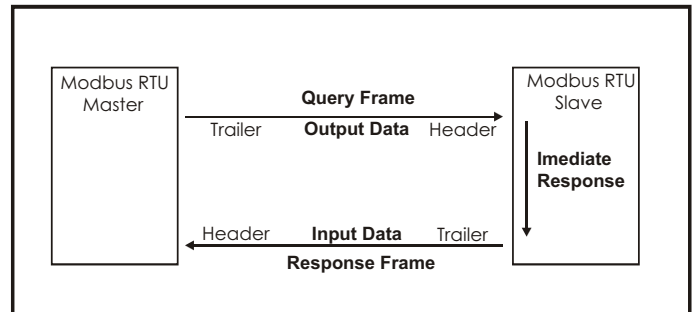

Address field

The address field of a message frame contains eight bits. The individual slave devices are assigned addresses in the range of 1 - 247. A master addresses a slave by placing the slave address in the address field of the message.

When the slave sends its response, it places its own address in this address field of the response to let the master know which slave is responding.

Function field

The function code field of a message frame contains eight bits. Valid codes are in the range of 1 - 6, 15, 16 and 23. When a message is sent from a master to a slave device, the function code field tells the slave what kind of action to perform.

Examples are:

- to read the ON/OFF states of a group of inputs;
- to read the data contents of a group of parameters;
- to read the diagnostic status of the slave;
- to write to designated coils or registers within the slave.

When the slave responds to the master, it uses the function code field to indicate either a normal (error-free) response or that some kind of error occurred (called an exception response). For a normal response, the slave simply echoes the original function code. For an exception response, the slave returns a code that is equivalent to the original function code with its most significant bit set to a logic 1.

In addition to its modification of the function code for an exception response, the slave places an unique code into the data field of the response message. This tells the master what kind of error occurred, or the reason for the exception.

The master device's application program has the responsibility of handling exception responses. Typical processes are to post subsequent retries of the message, to try diagnostic messages to the slave and to notify operators. Additional information about function codes and exceptions comes later.

Data field

The data field is constructed using sets of two hexadecimal digits (8 bits), in the range of 00 to FF hexadecimal.

The data field of messages sent from a master to slave devices contains additional information which the slave must use to take the action defined by the function code. This can include items like discrete and register addresses, the quantity of items to be handled and the count of actual data bytes in the field.

For example, if the master requests a slave to read a group of holding registers (function code 03), the data field specifies the starting register and how many registers are to be read. If the master writes to a group of registers in the slave (function code 10 hexadecimal), the data field specifies the starting register, how many registers to write, the count of data bytes to follow in the data field, and the data to be written into the registers.

If no error occurs, the data field of a response from a slave to a master contains the data requested. If an error occurs, the field contains an exception code that the master application can use to determine the next action to be taken.

CRC Error checking field

The error checking field contains a 16 bit value implemented as 2 bytes. The error check value is the result of a Cyclical Redundancy Check (CRC) calculation performed on the message contents.

The CRC field is appended to the message as the last field in the message. When this is done, the low-order byte of the field is appended first, followed by the high-order byte. The CRC high-order byte is the last byte to be sent in the message. Additional information about CRC calculation are found in this manual.

Functions

Standard MODBUS function codes.

| Function name | Function code |
|---------------------------------------|---------------|
| Read Coil (Bit) Status | 1 (01h) |
| Read Input Status | 2 (02h) |
| Read Holding Registers | 3 (03h) |
| Read Input Registers | 4 (04h) |
| Force Single Coil (Bit) | 5 (05h) |
| Force Single Register | 6 (06h) |
| Force Multiple Coils (Bits) | 15 (0Fh) |
| Force Multiple Registers | 16 (10h) |
| Force/Read Multiple Holding Registers | 23 (17h) |

Reading Input Status

Reading the status of digital information - read only.

EXAMPLE: Request digital input 2. Assuming it is not active.

Status: Modbus no = 2.

Request message.

| Field name | Hex value |
|---------------------|-----------|
| Slave address | 01 |
| Function | 02 |
| Start address HI | 00 |
| Start address LO | 02 |
| Number of Inputs HI | 00 |
| Number of Inputs LO | 01 |
| CRC LO | 18 |
| CRC HI | 0A |

Response message.

| Field name | Hex value |
|------------------------|-----------|
| Slave address | 01 |
| Function | 02 |
| Byte count | 01 |
| Input no.2 (02h)status | 00 |
| CRC LO | A1 |
| CRC HI | 88 |

Reading Holding Registers

Read the value of the analog variable information.

Example,

Asking for some Voltage, Frequency and Current. Their values are 400.0V, 60Hz and 15.5A.

400.0V, 0.1V unit - 4000 (0FA0h)

60Hz 1Hz unit - 60 (003Ch)

15.5A, 0.1A unit - 155 (009Bh)

Request message.

| Field name | Hex value |
|------------------------|-----------|
| Slave address | 01 |
| Function | 0 |
| Start address HI | 00 |
| Start address LO | 00 |
| Number of Registers HI | 00 |
| Number of Registers LO | 03 |
| CRC LO | 05 |
| CRC HI | CB |

Response message

| Field name | Hex value |
|-------------------------|-----------|
| Slave address | 01 |
| Function | 03 |
| Byte count | 06 |
| Reg no. 0, (0h) data HI | 0F |
| Reg no. 0, (0h) data LO | A0 |
| Reg no. 1, (1h) data HI | 00 |
| Reg no. 1, (1h) data LO | 3C |
| Reg no. 2, (2h) data HI | 00 |
| Reg no. 2, (2h) data LO | 9B |
| CRC LO | 20 |
| CRC HI | 34 |

Reading Coil Status

Read the status of mutable digital parameters.

Example

Requesting the state of coil input (Bit) 29. Assume it is on

30 input: Modbus no = 29 (1Dh)

On = Yes = 1 Coil = 0001

1 byte of data: Byte count=01

Request message.

| Field name | Hex value |
|--------------------|-----------|
| Slave address | 01 |
| Function | 01 |
| Start address HI | 00 |
| Start address LO | 1D |
| Number of Coils HI | 00 |
| Number of Coils LO | 01 |
| CRC LO | 6D |
| CRC HI | CC |

Response message.

| Field name | Hex value |
|-------------------------|-----------|
| Slave address | 01 |
| Function | 01 |
| Byte count | 01 |
| Coil no.29 (1Dh) status | 01 |
| CRC LO | 90 |
| CRC HI | 48 |

Reading Input Registers

Read the contents of the read-only analog information.

Example

Request the Modbus value 30011 - No. 10. Assume it is 452.0. It is long representation. 2 registers are used (30011 high word and 30012 low word)

452.0, unit 0.1 - 4520 (000011A8h).

Request message.

| Field name | Hex value |
|------------------------|-----------|
| Slave address | 01 |
| Function | 04 |
| Start address HI | 00 |
| Start address LO | 0A |
| Number of Registers HI | 00 |
| Number of Registers LO | 02 |
| CRC LO | 51 |
| CRC HI | C9 |

Response message.

| Field name | Hex value |
|--------------------------|-----------|
| Slave address | 01 |
| Function | 04 |
| Byte count | 04 |
| Reg no. 10 (0Ah) data HI | 00 |
| Reg no. 10 (0Ah) data LO | 00 |
| Reg no. 11 (0Bh) data HI | 11 |
| Reg no. 11 (0Bh) data LO | A8 |
| CRC LO | F6 |
| CRC HI | 6A |

Forcing Single Coil (Bit)

Set the status of a changeable digital parameter.

Example

Set a command to ON. This will cause some type of action.

Modbus no = 1 - LO address 1 (01h)

Execute = 1 - 0 Data HI = 255 (0FFh), Data LO = 00 (00h)

Request message..

| Field name | Hex value |
|------------------|-----------|
| Slave address | 01 |
| Function | 05 |
| Start address HI | 00 |
| Start address LO | 01 |
| Data HI | FF |
| Data LO | 00 |
| CRC LO | DD |
| CRC HI | FA |

Response message.

| Field name | Hex value |
|------------------|-----------|
| Slave address | 01 |
| Function | 05 |
| Start address HI | 00 |
| Start address LO | 01 |
| Data HI | FF |
| Data LO | 00 |
| CRC LO | DD |
| CRC HI | FA |

Force Multiple Coil

Set the status of several changeable digital parameters.

Example

Set one flag to ON and another to ON. This will cause some actions or change parameters. Coil n. = 0-1 Reset -> 1 // Run = 1 -> 00000011 (03h)

| Request message. | |
|----------------------------------|-----------|
| Field name | Hex value |
| Slave address | 01 |
| Function | 0F |
| Start address HI | 00 |
| Start address LO | 00 |
| Number of Coils HI | 00 |
| Number of Coils LO | 02 |
| Byte count | 01 |
| Coil no. 0-1 status (0000 0011B) | 03 |
| CRC LO | 9E |
| CRC HI | 96 |

Response message.

| Field name | Hex value |
|--------------------|-----------|
| Slave address | 01 |
| Function | 0F |
| Start address HI | 00 |
| Start address LO | 00 |
| Number of Coils HI | 00 |
| Number of Coils LO | 02 |
| CRC LO | D4 |
| CRC HI | 0A |

Forcing Multiple Registers

Set the contents of several changeable analog parameters.

Example

Set register 40018 (Modbus No. 17) to 25.0 (250 / 10) and 40019 (Modbus No. 18) to 55. 25.0, unit 0.1 -> -250 (00FAh) // 55, unit 1% -> 55 (0037h)

Request message.

| Field name | Hex value |
|------------------------|-----------|
| Slave address | 01 |
| Function | 10 |
| Start address HI | 00 |
| Start address LO | 11 |
| Number of Registers HI | 00 |
| Number of Registers LO | 02 |
| Byte count | 04 |
| Data HI reg 17 (11h) | 00 |
| Data LO reg 17 (11h) | FA |
| Data HI reg 18 (12h) | 00 |
| Data LO reg 18 (12h) | 37 |
| CRC LO | 52 |
| CRC HI | 88 |

Response message.

| Field name | Hex value |
|------------------------|-----------|
| Slave address | 01 |
| Function | 10 |
| Start address HI | 00 |
| Start address LO | 11 |
| Number of Registers HI | 00 |
| Number of Registers LO | 02 |
| CRC LO | 11 |
| CRC HI | CD |

Force/Read Multiple Register

Set and read the contents of multiple modifiable analog parameters in the same message.

Example

Set one parameter to 2 (40022 = Modbus No. 21) and another to 1 (40023 = Modbus No. 22) and read the other two. They are 1450 and 17000.

1450, unit 1 -> 1450 (05AAh)
17000, unit 1 -> 17000 (4268h)

| Request message. | |
|-------------------------|-----------|
| Field name | Hex value |
| Slave address | 01 |
| Function | 17 |
| Start read address HI | 00 |
| Start read address LO | 03 |
| Number of read Regs HI | 00 |
| Number of read Regs LO | 02 |
| Start write address HI | 00 |
| Start write address LO | 15 |
| Number of write Regs HI | 00 |
| Number of write Regs LO | 02 |
| Byte count | 04 |
| Data HI Reg 21 (15h) | 00 |
| Data LO Reg 21 (15h) | 02 |
| Data HI Reg 22 (16h) | 00 |
| Data LO Reg 22 (16h) | 01 |
| CRC LO | 62 |
| CRC HI | 77 |

| Response message. | |
|-------------------------|-----------|
| Field name | Hex value |
| Slave address | 01 |
| Function | 17 |
| Byte count | 04 |
| Reg no. 3, (3h) data HI | 05 |
| Reg no. 3, (3h) data LO | AA |
| Reg no. 4, (4h) data HI | 42 |
| Reg no. 4, (4h) data LO | 68 |
| CRC LO | E8 |
| CRC HI | 85 |

Exception response message..

| Field name | Hex value |
|----------------|-----------|
| Slave address | 01 |
| Function | 84 |
| Exception code | 02 |
| CRC LO | C2 |
| CRC HI | C1 |

Exception codes.

| Exc. code | Name | Description |
|-----------|----------------------|--|
| 01 | Illegal function | This unit doesn't support the function code. |
| 02 | Illegal data address | The data address is not within its boundaries. |
| 03 | Illegal data value | The data value is not within its boundaries. |
| 06 | Busy | The unit is unable to perform the request at this time. Retry later. |

In case of using an RS232 / RS485 Converter:

An RS485 is suitable for a multi-droop network.

In a multi-droop Modbus network, termination with resistors is required on the last slave unit of the two- or four-wire network cable.

These resistors increase noise immunity and their failure to install them compromises reliability. The network connection cables must be of good quality and shielded; the shield must be connected to ground at only one point. In networks that use two-wire cable over short distances, the use of twisted pair is acceptable.

There are two versions of converters on the market: one with a DIP switch to close the termination resistors and the other without a DIP switch or resistors. In the version without termination resistors, it is the user's responsibility to install the resistors directly on the connector cable of the last slave device in the network.

The value of these resistors must have an appropriate ohm value and must be connected between lines A / Ground and B / Ground.

Using Modbus Slave Communications

Overview:

The ZYGGOT RAddia allow the serial port to act as a Modbus/RTU slave. The Modbus function supports both ASCII and RTU modes (RTU configured by factory, ASCII under request) of operation across a range of baud rates and protocol frames. Also supported is port activity status, an in-activity timer and support for call-on-exception operation.

Basic Operation:

Before the Modbus function accepts messages, the Modbus must be activated pressing F5 (keyboard) for more than 3 seconds (Toggle).

Inactivity Timer:

The Modbus function contains a timer that is reset on the reception of a valid message addressed to this function. Should communications cease between the master and this function, that timer expires which sets an Inactivity timeout bit in the status word. Once communications is reestablished, both the timer and the Inactivity timeout bit in the status word are reset. Setting the timeout value to zero (at menu 13) disables this feature.

Report-on-exception:

Report-on-exception is a method of immediately informing the master that the slave has important information pending. This method is typically used in applications where modems are used as the communication channel, and the slaves are polled for data between long intervals. Once the connection is established, the master and slave require some cooperative functionality on determining the address of the slave calling. Since this functionality is not a standardized or a part of the Modbus protocol, the Modbus function contains two alternate methods such that the one most appropriate for the master is selected.

The first method involves the slave responding to the non-standard Modbus request Get Slave Address, which is broadcasted by the master after the connection is established. Since this is just a response to a Modbus request, this method does not require that Exception Messaging be enabled. This is method used by ZYGGOT. Use of this method with a third party master can require that master to be modified to support this command. The Modbus request and response frames are presented below:

Request:

| | |
|------|----------|
| ADDR | FUNC |
| 0 | 65 (41H) |

Response:

| | | |
|--------------|---------|--------------|
| ADDR | FUNC | DATA |
| (SLAVE ADDR) | 65(41H) | (SLAVE ADDR) |

The second method involves the slave sending an unsolicited response (Exception Message) to the master once the connection is established (available only by request). The specific byte pattern used for the Exception Message depends on that supported by the master. When sent, the appropriate header and checksums are inserted automatically by the Modbus function. The Byte Count acts as the trigger that starts the transmission of the response. When the Byte Count transitions from zero to a specific number, that number of bytes are sent. Once transmitted, the Modbus function responds to master requests as expected.

Master Mapping:

To access a memory point or memory flag over Modbus, the master must be configured as to the point's type and offset. This is usually accomplished with one of two methods. The first method uses the traditional addressing scheme where the high digit represents the point's type and the lower digits represent the point's offset (starting with point 1). Since only four types can be represented in this manner, the Modbus function packs several data tables into a single point type array.

The Traditional RTU Reference column below specifies the starting address of each table. The second method requires the master to be configured with the specific Modbus command and offset. The supported Modbus commands and the associated offset are also illustrated below.

| Reference | Maximum Range | Modbus Reference | Modbus Command(s) | ModbusOffset |
|-----------|-----------------------|------------------|---|--------------|
| %I1 | 2048 | 10001 | Read Input Status (2) | 00000 |
| %IG1 | 256 | 13001 | | 03000 |
| %S1 | 13 | 14001 | | 04000 |
| %K1 | 4 | 15001 | | 05000 |
| %Q1 | 2048 | 00001 | Read Flag Status (1) Force Flag (5) Force Multiple Flags (15) | 00000 |
| %M1 | 2048 | 03001 | | 03000 |
| %T1 | 2048 | 06001 | | 06000 |
| %QG1 | 256 | 09001 | | 09000 |
| %AI1 | 512 | 30001 | Read Input Register (4) | 00000 |
| %AIG1 | 32 | 33001 | | 03000 |
| %SR1 | 192 | 34001 | | 04000 |
| %Aq1 | 512 | 40001 | | 04000 |
| %R1 | 8192 (1024 Retentive) | 43001 | Read Holding Register (3) Load Register (6) Load Multiple Registers (16)00000 | 03000 |
| %AQQ1 | 32 | 46001 | | 06000 |

How to Connect a MODBUS slave device.

The physical device characteristics of the particular slave device determines the communications parameters required for connection. MODBUS is a multidrop communications protocol, (software), but typical RS-232 serial connections are not. RS-232 is basically a point-to-point hardware protocol with the transmit line of one device connected to the receive line of another device. Various combinations of protocol converters and/or modems may be used to multidrop RS-232 data links. Additionally, some serial cards may be configured to support 20 mA current loop for multidrop operation.

If a single slave device is to be connected, standard RS-232 hardware may be used. Depending upon the requirements of the master device, certain control signals may be required. These are typically RTS/CTS, (pins 4&5), or DTR/DSR/DCD, (pins 6,8 & 20). The ZYGGOT supports these control signals.

Communication port buffer

The ZYGGOT firmware maintains a transmit buffer and a receive buffer. When a Send or Receive task is executed, data is transferred between the appropriate buffer and the program registers.

For a «Comm Port Transmit» element, the «TX Count» word contains the number of characters moved from the program registers to the transmit buffer. This number may be less than the requested number if the comm port buffer is full.

For a «Comm Port Receive» element, the «RX Count» word contains the number of characters moved from the receive buffer into the program area. This number may be less than the requested number if the comm port buffer contains fewer characters than requested.

Serial Port

The serial port physically present on the ZYGGOT unit is referred to as COMM1.

Handshaking

Handshaking is a method by which the end destination of a transmission can control how much and when data is sent to it.

NOTE: For the purposes of this discussion, the source end is defined as the unit that is transmitting data. The destination end is defined as the unit that actually receives the data.

The handshake is configured in the ZYGGOT Raddia menu. There are five (5) possible types but only NONE, XON/XOFF and CLS/RTS are implemented in this device.

NONE -- There is no handshake. The source unit sends as many bytes of data as possible as quickly as possible for a given baud rate. No consideration is given to the capabilities of the destination end.

XON/XOFF -- (Also called software handshaking) The destination end keeps track of how many characters it has received and the size of its internal buffers. If the buffer becomes full or the unit is unable to receive any more characters, it must transmit the XOFF (transmit off) character. The source end must then stop transmitting data until a subsequent XON character is sent by the destination end.

Because there is some heavy software overhead involved, the timing of transmissions is variable. The destination must first determine that it is full and then transmit the XOFF signal. The source end must read the XOFF signal and react to it. In the meantime, several additional bytes of data may be sent. It is up to the destination end to ensure that it sends the XOFF signal soon enough so that the buffer does not overflow.

The XON and XOFF characters are predefined by the ASCII character set. XON is 11 hexadecimal or 17 decimal. XOFF is 13 hexadecimal or 19 decimal. XON/XOFF handshaking is most commonly used where only ASCII values are being sent. XON/XOFF cannot easily be used where binary data is involved, because the XON/XOFF codes are also valid binary codes.

Note that XON/XOFF handshaking usually implies a full duplex communication channel (both ends can transmit simultaneously), since the receiving end must transmit the XOFF characters at any time (including in the middle of a transmission from the source end).

The advantage of XON/XOFF handshaking is that it can be implemented using a simple and inexpensive three-wire (TX/RX/Common) cable.

| Reference | Maximum Range | Modbus Reference | Modbus Command(s) | ModbusOffset |
|-----------|-----------------------|------------------|---|--------------|
| %I1 | 2048 | 10001 | Read Input Status (2) | 00000 |
| %IG1 | 256 | 13001 | | 03000 |
| %S1 | 13 | 14001 | Read Flag Status (1) Force Flag (5) Force Multiple Flags (15) | 04000 |
| %K1 | 4 | 15001 | | 05000 |
| %Q1 | 2048 | 00001 | | 00000 |
| %M1 | 2048 | 03001 | | 03000 |
| %T1 | 2048 | 06001 | Read Input Register (4) | 06000 |
| %QG1 | 256 | 09001 | | 09000 |
| %AI1 | 512 | 30001 | | 00000 |
| %AIG1 | 32 | 33001 | | 03000 |
| %SR1 | 192 | 34001 | Read Holding Register (3) Load Register (6) Load Multiple Registers (16)00000 | 04000 |
| %Aq1 | 512 | 40001 | | 03000 |
| %R1 | 8192 (1024 Retentive) | 43001 | | 03000 |
| %AQG1 | 32 | 46001 | | 06000 |

How to Connect a MODBUS slave device.

The physical device characteristics of the particular slave device determines the communications parameters required for connection. MODBUS is a multidrop communications protocol, (software), but typical RS-232 serial connections are not. RS-232 is basically a point-to-point hardware protocol with the transmit line of one device connected to the receive line of another device. Various combinations of protocol converters and/or modems may be used to multidrop RS-232 data links. Additionally, some serial cards may be configured to support 20 mA current loop for multidrop operation.

If a single slave device is to be connected, standard RS-232 hardware may be used. Depending upon the requirements of the master device, certain control signals may be required. These are typically RTS/CTS, (pins 4&5), or DTR/DSR/DCD, (pins 6,8 & 20). The ZYGGOT supports these control signals.

Communication port buffer

The ZYGGOT firmware maintains a transmit buffer and a receive buffer. When a Send or Receive task is executed, data is transferred between the appropriate buffer and the program registers.

For a «Comm Port Transmit» element, the «TX Count» word contains the number of characters moved from the program registers to the transmit buffer. This number may be less than the requested number if the comm port buffer is full.

For a «Comm Port Receive» element, the «RX Count» word contains the number of characters moved from the receive buffer into the program area. This number may be less than the requested number if the comm port buffer contains fewer characters than requested.

Serial Port

The serial port physically present on the ZYGGOT unit is referred to as COMM1.

Handshaking

Handshaking is a method by which the end destination of a transmission can control how much and when data is sent to it.

NOTE: For the purposes of this discussion, the source end is defined as the unit that is transmitting data. The destination end is defined as the unit that actually receives the data.

The handshake is configured in the ZYGGOT Raddia menu. There are five (5) possible types but only NONE, XON/XOFF and CLS/RTS are implemented in this device.

NONE -- There is no handshake. The source unit sends as many bytes of data as possible as quickly as possible for a given baud rate. No consideration is given to the capabilities of the destination end.

XON/XOFF -- (Also called software handshaking) The destination end keeps track of how many characters it has received and the size of its internal buffers. If the buffer becomes full or the unit is unable to receive any more characters, it must transmit the XOFF (transmit off) character. The source end must then stop transmitting data until a subsequent XON character is sent by the destination end.

Because there is some heavy software overhead involved, the timing of transmissions is variable. The destination must first determine that it is full and then transmit the XOFF signal. The source end must read the XOFF signal and react to it. In the meantime, several additional bytes of data may be sent. It is up to the destination end to ensure that it sends the XOFF signal soon enough so that the buffer does not overflow.

The XON and XOFF characters are predefined by the ASCII character set. XON is 11 hexadecimal or 17 decimal. XOFF is 13 hexadecimal or 19 decimal. XON/XOFF handshaking is most commonly used where only ASCII values are being sent. XON/XOFF cannot easily be used where binary data is involved, because the XON/XOFF codes are also valid binary codes.

Note that XON/XOFF handshaking usually implies a full duplex communication channel (both ends can transmit simultaneously), since the receiving end must transmit the XOFF characters at any time (including in the middle of a transmission from the source end).

The advantage of XON/XOFF handshaking is that it can be implemented using a simple and inexpensive three-wire (TX/RX/Common) cable.

Register Types

Controllers offer a wide variety of Register Types. In most cases, the controller treats register types as if they were memory locations. The following is a list of register types implemented normally available but not all are available for the user.

%AI Analog Input

16-bit input registers used to gather analog input data such as voltages, temperatures, and speed settings coming from an attached device.

%AQ Analog Output

16-bit output registers used to send analog information such as voltages, levels or speed settings to an attached device.

%I Digital Input

Single-bit input registers. Typically, an external switch is connected to the registers.

%K Key Bit

Single-bit flags used to give the programmer direct access to any front panel keys appearing on a unit. Only the OCS series has keypads.

%Q Digital Output

Single-bit output registers. Typically, these bits are connected to an actuator, indicator light or alarm annunciator.

%R General Purpose Register

Retentive 16-bit registers.

%S System Bit

Single-bit bit coils predefined for system use.

%SR System Register

16-bit registers predefined for system use.

%T Temporary Bit

Non-retentive single-bit registers.

Bit-Mapped Addressing of 32-bit Registers

Bit-mapped addressing of 32-bit registers is not allowed. Bit offset values range from 1 to 16.

In order to access all 32 bits in a double register it is necessary to address the upper word of the register separately. Storage is such that the lower word is stored in the first (base) register, and the upper word is stored in the next consecutive register.

For example, if the 32-bit binary 0000000000000001 000000000000100 value (65540 decimal) is loaded into register %R43, %R43 contains 0000000000000100 and %R44 contains 0000000000000001. Therefore, to check Bit 17 of the DWORD stored at %R43, one must check Bit 1 of %R44, addressed as %R44.1.

Numbering Base

In ZYGGOT all offsets begin with 1 (one). 0 (zero) is not valid for register offset nor bit offset addressing.

Register offsets are thus in the range of 1 to X, where X is the maximum number of register in this model. For example, if the selected type has 2048 %R registers, they are addressed as %R01 through %R2048.

Bit Offsets are in the range of 1 to 16.

Groups of Boolean registers can be accessed as a 16-bit register. In this case, though, the Bit offset must lie on a 16-bit boundary, 1, 17, 33, etc.

MODBUS

MEMORY MAP FOR SERIAL AND ETHERNET COMMUNICATION TCP/IP AND HTTP

READ STATUS FLAGS (Coil M) - 1 Bit
(active = 1)
Default Offset = 3000
Reference - 3001
(Read Only)

%M1 Sensor Net Comm. OK
 %M2 Sensor Net Comm. Error
 %M3 Clear Data
 %M4 Restart Differential Data
 %M5 On Flash (Liga Flash)
 %M6 Reading Sensors
 %M7 Off Flash (Desliga Flash)
 %M8 Reserved
 %M9 Reserved
 %M10 Reserved
 %M11 Reserved
 %M12 Reserved
 %M13 Reserved
 %M14 Reserved
 %M15 Reserved
 %M16 Reserved
 %M17 Reserved
 %M18 Reserved
 %M19 Reserved
 %M20 Reserved
 %M21 Net Mute Command
 %M22 Net Reset Command
 %M23 Diff. Read. Temp.
 %M24 Simulating Diff.
 %M30 Modbus Error
 %M32 Modbus OK
 %M42 State Alarm Active
 %M43 State Trip Active
 %M47 State Fail Active
 %M57 Sensor Not Respondig
 %M59 Target Fail Active
 %M60 Receiver Fail Active
 %M63 All Sensor OK
 %M65 Target Alarm
 %M66 Target Trip
 %M67 Receiver Temp Alarm
 %M68 Receiver Temp Trip
 %M69 Flash On State
 %M70 Flash Off State
 %M81 DI1 Input On
 %M82 DI2 Input On
 %M83 DI3 Input On
 %M84 DI4 Input On
 %M91 Mute Input On
 %M92 Reset Input On

READ STATUS FLAGS (Coil M) - 1 Bit
(active = 1)
Default Offset = 3000
Reference - 3001
(Read Only)

%M241 State Group 1 Target Alarm
 %M242 State Group 1 Air Alarm
 %M243 State Group 2 Target Alarm
 %M244 State Group 2 Air Alarm
 %M245 State Group 3 Target Alarm
 %M246 State Group 3 Air Alarm
 %M247 State Group 4 Target Alarm
 %M248 State Group 4 Air Alarm
 %M249 State Group 5 Target Alarm
 %M250 State Group 5 Air Alarm
 %M251 to %M254 Reserved
 %M252 Reserved
 %M253 Reserved
 %M254 Reserved
 %M255 State Ext Fail 1 Alarm
 %M256 State Ext Fail 2 Alarm
 %M257 State Sensor Not Resp Alarm
 %M258 Reserved
 %M259 State Target Alarm
 %M260 State Target Trip
 %M261 State Air Alarm
 %M262 State Air Trip
 %M263 State Differential Alarm
 %M264 State Differential Trip
 %M265 State G1 Target Trip
 %M266 State G1 Air Trip
 %M267 State G2 Target Trip
 %M268 State G2 Air Trip
 %M269 State G3 Target Trip
 %M270 State G3 Air Trip
 %M271 State G4 Target Trip
 %M272 State G4 Air Trip
 %M273 State G5 Target Trip
 %M274 State G5 Air Trip
 %M275 Reserved
 %M276 Reserved
 %M277 Reserved
 %M278 State Analog 1 Alarm
 %M279 State Analog 1 Trip
 %M280 State Analog 2 Alarm
 %M281 State Analog 2 Trip
 %M282 State Analog 3 Alarm
 %M283 State Analog 3 Trip
 %M284 State Analog 4 Alarm
 %M285 State Analog 4 Trip
 %M286 to %M293 Reserved
 %M294 State System Operat. Hour
 %M295 Modbus Error Alarm
 %M296 Sensor Communication Fail
 %M297 Auto Save Target Fail
 %M298 Reserved
 %M299 Memory Card Error
 %M300 Reserved

READ/WRITE STATUS FLAGS (Coil M) - 1 Bit (active = 1)
Default Offset = 3000
Reference - 3001
(Read / Write)

%M101 Plot 1 Restart
 %M102 Plot 2 Restart
 %M103 Plot 3 Restart
 %M104 Plot 4 Restart
 %M105 Plot 5 Restart
 %M106 Plot 6 Restart
 %M107 Plot 7 Restart
 %M108 Plot 8 Restart
 %M109 Plot 9 Restart
 %M110 Plot 10 Restart
 %M111 Plot 11 Restart
 %M112 Plot 12 Restart
 %M113 Plot 13 Restart
 %M114 Plot 14 Restart
 %M115 Plot 15 Restart
 %M116 Plot 16 Restart
 %M117 Plot 17 Restart

| Tipo de dado MODBUS | Tamanho |
|---------------------|---------|
| Coil | 1 bit |
| Holding Register | 16 bits |

| Tipos de dados MODBUS | Função | Código |
|-----------------------|---------|--------|
| Coil | Leitura | 0x01 |
| | Escrita | 0x05 |
| Holding Register | Leitura | 0x03 |
| | Escrita | 0x06 |

MODBUS

MEMORY MAP FOR SERIAL AND ETHERNET COMMUNICATION TCP/IP AND HTTP

**READ STATUS FLAGS (Coil M) - 1 Bit
(active = 1)
Default Offset = 3000
Reference - 3001
(Read Only)**

%M301 Fail Active Operating Hour
%M302 Fail Active Sensor Comm.
%M303 Fail Active Not Responding
%M304 Reserved
%M305 Reserved
%M306 Fail Active Target Alarm
%M307 Fail Active Target Trip
%M308 Fail Active Receiver Alarm
%M309 Fail Active Receiver Trip
%M310 Fail Active Differ. Alarm
%M311 Fail Active Analog 1 Alarm
%M312 Fail Active Analog 2 Alarm
%M313 Fail Active Analog 3 Alarm
%M314 Fail Active Analog 4 Alarm
%M315 Fail Active Analog 1 Trip
%M316 Fail Active Analog 2 Trip
%M317 Fail Active Analog 3 Trip
%M318 Fail Active Analog 4 Trip
%M319 Fail Active Ext Fail 1
%M320 Fail Active Ext Fail 2
%M321 Fail Active Differ. Trip
%M331 Reserved
%M332 Reserved
%M333 Reserved
%M334 Reserved
%M335 Reserved
%M336 Reserved
%M337 Reserved
%M338 Reserved
%M339 Reserved
%M340 Reserved
%M341 Fail Active G1 Target Alarm
%M342 Fail Active G2 Target Alarm
%M343 Fail Active G3 Target Alarm
%M344 Fail Active G4 Target Alarm
%M345 Fail Active G5 Target Alarm
%M346 Fail Active G1 Target Trip
%M347 Fail Active G2 Target Trip
%M348 Fail Active G3 Target Trip
%M349 Fail Active G4 Target Trip
%M350 Fail Active G5 Target Trip

**DATA READING (Register R)
(16-Bit Integers).
Default Offset = 3000
Reference = 43001
(Read Only)**

%R2001 Sensor 1 Target Temper.
to
%R2125 Sensor 125 Target Temper.

**READ STATUS FLAGS (Coil M) - 1 Bit
(active = 1)
Default Offset = 3000
Reference - 3001
(Read Only)**

%M401 Receiver Comm. OK
%M402 Receiver Comm. Error
%M403 Receiver Net Timeout
%M404 Receiver Net Frame Parity
%M405 Receiver Net CRC Check
%M406 Rcvr Net Unespect. Resp.
%M407 Receiver Net Reject Comm.
%M408 Receiver Net Reject Data
%M409 Alarm Not Acknowledged
%M410 Alarm Not Cleared
%M411 Differential Function On
%M412 Differential Warm OK
%M413 Differential First Read Done
%M414 Differential Read Valid
%M415 Reserved
%M416 Reserved
%M417 Reserved
%M418 Reserved
%M419 Reserved
%M420 Reserved
%M421 Digital Input 1 On
%M422 Digital Input 2 On
%M423 Digital Input 3 On
%M424 Digital Input 4 On
%M425 EB1: Digital Input 1
%M426 EB2: Digital Input 2
%M427 EB3: Digital Input 3
%M428 EB4: Digital Input 4
%M429 EB5: Digital Input 5
%M431 EB6: Digital Input 6
%M431 EB7: Digital Input 7
%M432 EB8: Digital Input 8
%M433 to %M440 Reserved
%M441 Digital Output 1 MUTE
%M442 Digital Output 2 RESET
%M443 Digital Output 3 D.O.3
%M444 Digital Output 4 D.O.4
%M445 EB1: AUX 1
%M446 EB2: AUX 2
%M447 EB3: AUX 3
%M448 EB4: AUX 4
%M449 EB5: AUX 5
%M450 EB6: AUX 6
%M451 EB7: AUX 7
%M452 EB8: AUX 8
%M453 to %M 460 Reserved

**READ STATUS FLAGS (Coil M) - 1 Bit
(active = 1)
Default Offset = 3000
Reference - 3001
(Read Only)**

%M501 Sensor 001 Not Responding
to
%M625 Sensor 125 Not Responding

**FLAGS DE ESTADO (R) - 1 Bit
(Não mapeáveis no protocolo normal).
Nota: Ler Registro 16 Bits Normalmente.
Offset Padrão 3000
Reference = 43001
e testar valor do Bit 2.
(Read Only)**

%R5001.2 Target Alarm Sensor 1
to
%R5125.2 Target Alarm Sensor 125

%R6001.2 Target Trip Sensor 1
to

**DATA READINGS (Register R)
Default Offset = 3000
Reference = 43001
(Read Only)**

%R981 H. On at Diff Start (32 Bit)
%R987 M. On at Diff Start (16 Bit)
%R985 Total Diff Time Hour (32 Bit)
%R988 Total Diff Time Min. (16 Bit)
%R1915 Time to Warm Hour (16 Bit)
%R1913 Time to Warm Min. (16 Bit)
%R1007 Time to Restart H. (16 Bit)
%R1003 Time to Restart M. (16 Bit)
%R1081 > Target Temper. (16 Bit)
%R1082 > Air Temperat. (16 Bit)
%R1330 N. Sensors Resp. (16 Bit)
%R1333 N. Sens. Not Resp (16 Bit)
%R1079 Total Alarms (16 Bits)
%R1083 Total Trips (16 Bits)
%R3051 Analog 1 Value (16 Bit)
%R3053 Analog 2 Value (16 Bit)
%R3053 Analog 3 Value (16 Bit)
%R3054 Analog 4 Value (16 Bit)
%R1192 =1 // Unity = % (16 Bit)
%R1192 =2 // Unity = °C (16 Bit)
%R1192 =4 // Unity = °F (16 Bit)

MEMORY MAP FOR SERIAL AND ETHERNET COMMUNICATION TCP/IP AND HTTP

PARAMETERS (Register R)
Menu: RELAY CONFIG
Default Offset = 3000
Reference = 43001
(Read / Write)

%R801 Language
 (0=English/1=Português/2=Espanhol)
 %R879 Screen Brightness (50-100%)
 %R790.2 Save Screen (0=No/1=Yes)
 %R860 Save Screen Time (5-200 min)
 %R881 Saving Brightness (5-50%)
 %R760 - %R764 Plant (10 Bytes ASCII)
 %R770 - %R774 Location (10 Bytes ASCII)
 %R780 - %R784 Panel (10 Bytes ASCII)
 %R809 Memory Card Error Action
 (0=None/1=Log)

PARAMETERS (Register R)
Menu: PARAMETERS CONFIG
Default Offset = 3000
Reference = 43001
(Read / Write)

%R790.1 Centigrades / Fahrenheit (0/1)
 %R802 Reset On Fail Unacknowledged
 (0=No/1=Yes)
 %R840 Reset On Fail Active
 (0=No/1=Yes)
 %R803 Reserved
 %R804 Receiver Alarm Level (0-999)
 %R805 Receiver Trip Level (0-999)
 %R806 Call Screen On Fail (0=No/1=Yes)
 %R807 Call Screen On Alarm
 (0=No/1=Yes)
 %R1010.1 Reserved
 %R1010.2 Reserved
 %R808 Return to Main Time (0=no/0-3600 s)

PARAMETERS (Register R)
Menu: SENSORS
Default Offset = 3000
Reference = 43001
(Read / Write)

%R810 Total Sensor Number (1-125)
 %R891 Auto Save Target Data (0/1)
 %R892 Reserved
 %R850 Save Method (0=Always to the Same File/1=New File Each Start)
 %R859 Save Period (10-1440 m)
 %R839 Start New File (0=No/1=Yes)
 %R849 Read Write Fail Action
 (0=None/1=Log)

PARAMETERS (Register R)
Menu: ANALOG INPUTS
Standard Offset = 3000
Reference = 43001
(Read/Write)

%R751 - %R753 Ai1 Name (6 Bytes ASCII)
 %R754 - %R756 Ai2 Name (6 Bytes ASCII)
 %R757 - %R759 Ai3 Name (6 Bytes ASCII)
 %R787 - %R790 Ai4 Name (6 Bytes ASCII)
 %R831 Read Mode (0=%/1=Temp)
 %R832 Scale (10 - 99999)

PARAMETERS (Register R)
Menu: BLOCK PROGRAMMING
Standard Offset = 3000
Reference = 43001
(Read/Write)

%R811 Block 1 Start (1-125)
 %R812 Block 1 End (1-125)
 %R821 Block 1 Target Alarm (0-999)
 %R821 Block 1Target Trip (0-999)
 %R813 Block 2 Start (1-125)
 %R814 Block 2 End (1-125)
 %R823 Block 2 Target Alarm (0-999)
 %R824 Block 2Target Trip (0-999)
 %R815 Block 3 Start (1-125)
 %R816 Block 3 End (1-125)
 %R825 Block 3 Target Alarm (0-999)
 %R826 Block 3Target Trip (0-999)
 %R817 Block 4 Start (1-125)
 %R818 Block 4 End (1-125)
 %R827 Block 4 Target Alarm (0-999)
 %R828 Block 4Target Trip (0-999)
 %R819 Block 5 Start (1-125)
 %R820 Block 6 End (1-125)
 %R829 Block 7 Target Alarm (0-999)
 %R830 Block 8Target Trip (0-999)

PARAMETERS (Register R)
Menu: MODBUS CONFIG
Default Offset = 3000
Reference = 43001
(Read / Write)

%R841 Baud Rate (1=9600/2=19200/4=38400)
 %R842 Address (1-247)
 %R843 Parity (1=None/2=Odd/4=Even)
 %R844 Handshake
 (1=None/2=XON/XOF/4=CTS/RTS/8=MD/Half)
 %R845 Timeout (0-1023 s)
 %R846 Stop Bits (1=1/2=2)
 %R847 Port Mode (1=RS232)
 %R848 Modbus (0=Inactive/1=Active)

PARAMETERS (Register R)
Menu: TRENDING CONFIG
Standard Offset = 3000
Reference = 43001
(Read/Write)

%R835 Scale (0-9999)
 %R837 HMI Reset (0=Disable/1=Enable)
 %R838.1 Enable Retentive (0=No/1=Yes)

PARAMETERS (Register R)
Menu: PROTECTIONS EXTERNAL FAIL
Standard Offset = 3000
Reference = 43001
(Read/Write)

Options for Alarm Action (0=None / 1=Log / 2=Alarm)
Options for Trip Action (0=None / 1=Log / 4=Trip)
Options for D. Output (0=None / 1=D.O.3 / 2=D.O.4 / 4=Aux1 / 8=Aux2 / 16=Aux3 / 32=Aux4 / 64=Aux5 / 128=Aux6 / 256=Aux7 / 512=Aux8)

%R977 External Fail 1 Action
 %R983 External Fail 1 Trip Delay (0-999 x 0,1 s)
 %R979 External Fail D. Output
 %R767 - %R769 External Fail Assign Name (6 Bytes ASCII)

%R978 External Fail 1 Action
 %R984 External Fail 1 Trip Delay (0-999 x 0,1 s)
 %R980 External Fail D. Output
 %R777 - %R779 External Fail Assign Name (6 Bytes ASCII)

MODBUS

MEMORY MAP FOR SERIAL AND ETHERNET COMMUNICATION TCP/IP AND HTTP

PARAMETERS (Register R)

Menu: PROTECTIONS

Default Offset = 3000

Reference = 43001

(Read / Write)

Options for Alarm Action: (0=None / 1=Log / 2=Alarm)

Options for Trip Action: (0=None / 1=Log / 4=Trip)

Options for D. Output: (0=None / 1=D.O.3 / 2=D.O.4 / 4=Aux1 / 8=Aux2 / 16=Aux3 / 32=Aux4 / 64=Aux5 / 128=Aux6 / 256=Aux7 / 512=Aux8)

%R862 Note Respond Action
 %R863 Note Resp. D. Output
 %R864 Target Alarm Action
 %R865 Target Alarm D. Output
 %R868 Note Respond Action
 %R869 Note Resp. D. Output
 %R866 Receiver Alarm Action
 %R867 Receiver Alarm D. Output
 %R870 Receiver Trip Action
 %R871 Receiver Trip D. Output
 %R877 Sensor Comm. Fail Action
 %R878 Sensor Comm Fail D. Output
 %R857 Modbus Comm. Fail Action
 %R858 Modbus Comm. Fail Aux Output

%R1020 Differential - Execute Diff (0=Non/1=Yes)
 %873 Differential Alarm Level (0-200%)
 %874 Differential Trip Level (0-200%)
 %R1016 Differential Alarm Action
 %R1017 Differential Trip Action
 %R875 Differential Warmup Hours (0-50 h)
 %R1018 Differential Restart Period (0-10000 h) (0=No)
 %R876 Differential D. Output

%R880 Operating Time Action
 %R893 Operating Time Level (0- 250000 h)

PARAMETERS (Register R)

Menu: TARGET ALARM LEVELS

Standard Offset = 3000

Reference = 43001

(Read/Write)

%R501 Sensor 1 Target Alarm Level (0-999)
 %R502 Sensor 2 Target Alarm Level (0-999)

PARAMETERS (Register R)

Menu: TARGET TRIP LEVELS

Standard Offset = 3000

Reference = 43001

(Read/Write)

%R626 Sensor 1 Target Trip Level (0-999)
 %R627 Sensor 2 Target Trip Level (0-999)
 ===
 %R750 Sensor 125 Target Trip Level (0-999)

PARAMETERS (Register R)

Menu: PROTECTIONS GROUP

Standard Offset = 3000

Reference = 43001

(Read/Write)

Options for Alarm Action: (0=None / 1=Log / 2=Alarm)

Option for Trip Action: (0=None / 1=Log / 4=Trip)

Options for Aux Output: (0=None / 1=D.O.3 / 2=D.O.4 / 4=Aux1 / 8=Aux2 / 16=Aux3 / 32=Aux4 / 64=Aux5 / 128=Aux6 / 256=Aux7 / 512=Aux8)

%R901 Group 1 Target Alarm Action
 %R906 Group 1 Target Trip Action
 %R911 Reserved
 %R916 Reserved
 %R921 Group 1 Target Alarm D. Output
 %R926 Group 1 Target Trip D. Output
 %R931 Reserved
 %R936 Reserved

%R902 Group 2 Target Alarm Action
 %R907 Group 2 Target Trip Action
 %R912 Group 2 Reserved
 %R917 Group 2 Reserved
 %R922 Group 2 Target Alarm D. Output
 %R927 Group 2 Target Trip D. Output
 %R932 Group 2 Reserved
 %R937 Group 2 Reserved

%R903 Group 3 Target Alarm Action
 %R908 Group 3 Target Trip Action
 %R913 Group 3 Reserved
 %R918 Group 3 Reserved
 %R923 Group 3 Target Alarm D. Output
 %R928 Group 3 Target Trip D. Output
 %R933 Group 3 Reserved
 %R938 Group 3 Reserved

%R904 Group 4 Target Alarm Action
 %R909 Group 4 Target Trip Action
 %R914 Group 4 Reserved
 %R919 Group 4 Reserved
 %R924 Group 4 Target Alarm D. Output
 %R929 Group 4 Target Trip D. Output
 %R934 Group 4 Reserved
 %R939 Group 4 Reserved

%R905 Group 5 Target Alarm Action
 %R910 Group 5 Target Trip Action
 %R915 Group 5 Reserved
 %R920 Group 5 Reserved
 %R925 Group 5 Target Alarm D. Output
 %R930 Group 5 Target Trip D. Output
 %R935 Group 5 Reserved
 %R940 Group 5 Reserved

PARAMETERS (Register R)

Menu: PROTECTIONS ANALOG

Default Offset = 3000

Reference = 43001

(Read / Write)

Options for Alarm Action: (0=None / 1=Log / 2=Alarm)

Options for Trip Action: (0=None / 1=Log / 4=Trip)

Options for Aux Output: (0=None / 1=D.O.3 / 2=D.O.4 / 4=Aux1 / 8=Aux2 / 16=Aux3 / 32=Aux4 / 64=Aux5 / 128=Aux6 / 256=Aux7 / 512=Aux8)

%R961 Analog 1 Alarm Action
 %R883 Analog 1 Alarm Level High (0-100 %)
 %R969 Analog 1 Alarm D. Output
 %R965 Analog 1 Trip Action
 %R887 Analog 1 Trip Level High (0-100 %)
 %R973 Analog 1 Trip D. Output

%R962 Analog 2 Alarm Action
 %R884 Analog 2 Alarm Level High (0-100 %)
 %R970 Analog 2 Alarm D. Output
 %R966 Analog 2 Trip Action
 %R888 Analog 2 Trip Level High (0-100 %)
 %R974 Analog 2 Trip D. Output

%R963 Analog 3 Alarm Action
 %R854 Analog 3 Alarm Level High (0-100 %)
 %R971 Analog 3 Alarm D. Output
 %R967 Analog 3 Trip Action
 %R889 Analog 3 Trip Level High (0-100 %)
 %R975 Analog 3 Trip D. Output

%R964 Analog 4 Alarm Action
 %R855 Analog 4 Alarm Level High (0-100 %)
 %R972 Analog 4 Alarm D. Output
 %R968 Analog 4 Trip Action
 %R890 Analog 4 Trip Level High (0-100 %)

MODBUS OVER ETHERNET TCP IP SERVER

GENERAL SPECIFICATIONS (PART 1 / 4)

MODBUS OVER ETHERNET IP SERVER COMMUNICATION WILL WORK WITH PLCs AND ALLEN BRADLEY PROTOCOL OR ALLEN BRADLEY LIKE

Maximum connection = 2 /// PORT = 44818 TCP or 2222 UDP

SEND (PRODUCED) FIRST REGISTER = %R2801 /// LAST REGISTER = %R2928 /// WORDS COUNT = 128

RECEIVE (CONSUMED) FIRST REGISTER = %R3201 /// LAST REGISTER = %R3328 /// WORDS COUNT = 128

The Status word provides Ethernet/IP connection status. The upper byte of the word

contains the Class 3 (Explicit) connection count and the lower byte contains the Class 1 (IO) connection count.

NOTE: When the Status word indicates no connections, the Consumed OCS registers contain old data

As up to 128 words are allowed in each communication, a pagination scheme is used to access all important and available data.

In this version, parameter programming via the Ethernet connection is not allowed, so the variable on the corresponding screen is permanently set to "Disabled"

However, it is allowed to send some commands via the Ethernet connection, in addition to specifying the page to be read.

IN THE PLC CONNECTION PARAMETER, USE "100" FOR THE ASSEMBLY INSTANCE INPUT WITH SIZE = 128 AND USE "101" FOR THE ASSEMBLY INSTANCE OUTPUT WITH SIZE = 128

| CONSUMED | WRITE PAGE | FUNCTION | DATA | NOTE | WARNING |
|----------------|------------|----------------------------|---|---|---------|
| %R3201 - %3300 | XXX | RESERVED | | | |
| %R3301 | 0 | MUTE | 1= MUTE // 0 = DO NOTHING | SEND COMMAND MUTE TO RELAY | |
| %R3302 | 0 | RESET | 1= RESET // 0 = DO NOTHING | SEND COMMAND RESET TO RELAY | |
| %R3303 | 0 | SAVE TARGET | 1= SAVE // 0 = DO NOTHING | SAVE TARGET DATA TO MEMORY CARD | |
| %R3304 | 0 | RESERVED | 1= SAVE // 0 = DO NOTHING | SAVE AIR DATA TO MEMORY CARD | |
| %R3305 | 0 | RESERVED | | | |
| %R3306 | 0 | RESERVED | | | |
| %R3307 | 0 | RESERVED | | | |
| %R3308 | 0 | TIME STAMP EVENT | SET 1 TO 50 | | |
| %R3309 | 0 | RESET DIFFERENTIAL WARM | 1= RESET DIFFERENTIAL // 0 = DO NOTHING | RESET DIFFERENTIAL WITH A NEW WARM PERIOD | CAUTION |
| %R3310 | 0 | RESET DIFFERENTIAL NO WARM | 1= RESET DIFFERENTIAL // 0 = DO NOTHING | RESET DIFFERENTIAL WITHOUT A NEW WARM PERIOD | CAUTION |
| %R3311 | 0 | RESERVED | | | |
| %R3312 | 0 | RESERVED | | | |
| %R3313 | 0 | RESERVED | | | |
| %R3314 | 0 | RESERVED | | | |
| %R3315 | 0 | RESERVED | | | |
| %R3316 | 0 | RESERVED | | | |
| %R3317 | 0 | RESERVED | | | |
| %R3318 | 0 | RESERVED | | | |
| %R3319 | 0 | RESERVED | | | |
| %R3320 | 0 | RESERVED | | | |
| %R3321 | 0 | RESERVED | | | |
| %R3322 | 0 | RESERVED | | | |
| %R3323 | 0 | RESERVED | | | |
| %R3324 | 0 | RESERVED | | | |
| %R3325 | 0 | RESERVED | | | |
| %R3326 | 0 | PAGE TO WRITE | NOTE USED IS THIS VERSION | 0 = DO NOTHING // 1 TO 15 SET PAGE TO BE READED | |
| %R3327 | 0 | PAGE TO READ | SET PAGE FROM 0 TO 15 TO BE READED FROM RELAY | NOTE USED IN THIS VERSION | |
| %R3328 | 0 | WRITING DATA VALID | 1= DATA TO BE WRITE = VALID // 0 = DO NOTHING | | |

MODBUS OVER ETHERNET TCP IP SERVER

GENERAL SPECIFICATIONS (PART 3 / 4)

| PRODUCED | Controller Tags | READ PAGE | FUNCTION | DATA | NOTE | WARNING |
|----------|-----------------|-----------|---------------------------|-------------------|------|---------|
| %R2826 | I.Data[25] | 15 | ANALOG 1 ALARM ACTIVE | 0 = NO // 1 = YES | | |
| %R2827 | I.Data[26] | 15 | ANALOG 2 ALARM ACTIVE | 0 = NO // 1 = YES | | |
| %R2828 | I.Data[27] | 15 | ANALOG 3 ALARM ACTIVE | 0 = NO // 1 = YES | | |
| %R2829 | I.Data[28] | 15 | ANALOG 4 ALARM ACTIVE | 0 = NO // 1 = YES | | |
| %R2830 | I.Data[29] | 15 | ANALOG 1 TRIP ACTIVE | 0 = NO // 1 = YES | | |
| %R2831 | I.Data[30] | 15 | ANALOG 2 TRIP ACTIVE | 0 = NO // 1 = YES | | |
| %R2832 | I.Data[31] | 15 | ANALOG 3 TRIP ACTIVE | 0 = NO // 1 = YES | | |
| %R2833 | I.Data[32] | 15 | ANALOG 4 TRIP ACTIVE | 0 = NO // 1 = YES | | |
| %R2834 | I.Data[33] | 15 | EXCESS LIFE ACTIVE | 0 = NO // 1 = YES | | |
| %R2835 | I.Data[34] | 15 | DIFFERENTIAL ALARM ACTIVE | 0 = NO // 1 = YES | | |
| %R2836 | I.Data[35] | 15 | DIFFERENTIAL TRIP ACTIVE | 0 = NO // 1 = YES | | |
| %R2837 | I.Data[36] | 15 | REMOTE 1 ACTIVE | 0 = NO // 1 = YES | | |
| %R2838 | I.Data[37] | 15 | REMOTE 2 ACTIVE | 0 = NO // 1 = YES | | |
| %R2839 | I.Data[38] | 15 | G1 TARGET ALARM ACTIVE | 0 = NO // 1 = YES | | |
| %R2840 | I.Data[39] | 15 | G2 TARGET ALARM ACTIVE | 0 = NO // 1 = YES | | |
| %R2841 | I.Data[40] | 15 | G3 TARGET ALARM ACTIVE | 0 = NO // 1 = YES | | |
| %R2842 | I.Data[41] | 15 | G4 TARGET ALARM ACTIVE | 0 = NO // 1 = YES | | |
| %R2843 | I.Data[42] | 15 | G5 TARGET ALARM ACTIVE | 0 = NO // 1 = YES | | |
| %R2844 | I.Data[43] | 15 | G1 AIR ALARM ACTIVE | 0 = NO // 1 = YES | | |
| %R2845 | I.Data[44] | 15 | G2 AIR ALARM ACTIVE | 0 = NO // 1 = YES | | |
| %R2846 | I.Data[45] | 15 | G3 AIR ALARM ACTIVE | 0 = NO // 1 = YES | | |
| %R2847 | I.Data[46] | 15 | G4 AIR ALARM ACTIVE | 0 = NO // 1 = YES | | |
| %R2848 | I.Data[47] | 15 | G5 AIR ALARM ACTIVE | 0 = NO // 1 = YES | | |
| %R2849 | I.Data[48] | 15 | G1 TARGET TRIP ACTIVE | 0 = NO // 1 = YES | | |
| %R2850 | I.Data[49] | 15 | G2 TARGET TRIP ACTIVE | 0 = NO // 1 = YES | | |
| %R2851 | I.Data[50] | 15 | G3 TARGET TRIP ACTIVE | 0 = NO // 1 = YES | | |
| %R2852 | I.Data[51] | 15 | G4 TARGET TRIP ACTIVE | 0 = NO // 1 = YES | | |
| %R2853 | I.Data[52] | 15 | G5 TARGET TRIP ACTIVE | 0 = NO // 1 = YES | | |
| %R2854 | I.Data[53] | 15 | RESERVED | | | |
| %R2855 | I.Data[54] | 15 | RESERVED | | | |
| %R2856 | I.Data[55] | 15 | RESERVED | | | |
| %R2857 | I.Data[56] | 15 | RESERVED | | | |
| %R2858 | I.Data[57] | 15 | RESERVED | | | |
| %R2859 | I.Data[58] | 15 | RESERVED | | | |
| %R2860 | I.Data[59] | 15 | RESERVED | | | |
| %R2861 | I.Data[60] | 15 | RESERVED | | | |
| %R2862 | I.Data[61] | 15 | RESERVED | | | |
| %R2863 | I.Data[62] | 15 | RESERVED | | | |
| %R2864 | I.Data[63] | 15 | RESERVED | | | |

MODBUS OVER ETHERNET TCP IP SERVER

GENERAL SPECIFICATIONS (PART 4 / 4)

| PRODUCED | READ PAGE | FUNCTION | DATA | NOTE | WARNING |
|----------|-----------|-----------------------------------|--|---|---------|
| %R2865 | 15 | SCREEN ALARM UNCLEARED | 0 = NO // 1 = YES | | |
| %R2866 | 15 | SCREEN ALARM UNACKNOWLEDGED | 0 = NO // 1 = YES | | |
| %R2867 | 15 | SCREEN ALARM ANY FAIL ACTIVE | 0 = NO // 1 = YES | | |
| %R2868 | 15 | RESERVED | | | |
| %R2869 | 15 | RESERVED | | | |
| %R2801 | 16 | MAX POINT TEMPERATURE | x 10 - AS READED (FORMAT XXX.X) | THE DATA NEED TO BE DIVIDED BY 10 TO INSERT THE COMA | |
| %R2802 | 16 | RECEIVER TEMPERATURE | x 10 - AS READED (FORMAT XXX.X) | THE DATA NEED TO BE DIVIDED BY 10 TO INSERT THE COMA | |
| %R2803 | 16 | MEMORY CARD STATUS | 0=OK// 1= UNKNOWN FORMAT// 2=NO CARD// | 3= NOT SUPPORTED//4=ILEGAL SWAP//5=UNKNOWN//PROTECTED | |
| %R2804 | 16 | DIFFERENTIAL TIME TO WARM HOUR | AS READED | | |
| %R2805 | 16 | DIFFERENTIAL TIME TO WARM MINUTE | AS READED | | |
| %R2806 | 16 | DIFFERENTIAL TIME TO RESTART HOUR | AS READED | | |
| %R2807 | 16 | DIFFERENTIAL TIME TO RSTRT MINUTE | AS READED | | |
| %R2808 | 16 | DIFFERENTIAL ON | 0 = NO // 1 = YES | | |
| %R2809 | 16 | DIFFERENTIAL WARM OK | 0 = NO // 1 = YES | | |
| %R2810 | 16 | DIFFERENTIAL FIRST READ OK | 0 = NO // 1 = YES | | |
| %R2811 | 16 | DIFFERENTIAL VALID (OPERATING) | 0 = NO // 1 = YES | | |
| %R2812 | 16 | REDING THM SENSOR NUMBER | AS READED (1 TO 100) | | |
| %R2813 | 16 | SCANNING GATEWAY NUMBER | AS READED (1 TO 40) | | |
| %R2814 | 16 | REDING ARC SENSOR NUMBER | AS READED (1 TO 100) | | |
| %R2815 | 16 | TOTAL SENSOR RESPONDING | 0 TO 100 | | |
| %R2816 | 16 | TOTAL SENSOR NOT RESPONDING | 0 TO 100 | | |
| %R2817 | 16 | TOTAL ALRM ACTIVE | | | |
| %R2818 | 16 | TOTAL TRIP ACTIVE | | | |
| %R2819 | 16 | RESERVED | | | |
| %R2820 | 16 | RESERVED | | | |
| %R2821 | 16 | RESERVED | | | |
| %R2822 | 16 | RESERVED | | | |
| %R2823 | 16 | REAL TIME CLOCK DAY | AS READED (600 TO 0 s) | | |
| %R2824 | 16 | REAL TIME CLOCK MONTH | 1 TO 31 | | |
| %R2825 | 16 | REAL TIME CLOCK YEAR | 1 TO 12 | | |
| %R2826 | 16 | REAL TIME CLOCK HOUR | 0 TO 24 | | |
| %R2827 | 16 | REAL TIME CLOCK MINUTE | 0 TO 60 | | |
| %R2828 | 16 | REAL TIME CLOCK SECONDS | 0 TO 60 | | |
| %R2829 | 16 | RESERVED | 1 TO 40 | | |

MODBUS OVER ETHERNET TCP IP SERVER

ETHERNET MODULE IN STUDIO 5000/LOGIX DESIGNER ALLEN BRADLEY

Steps to create an Ethernet module in a project in Studio 5000/Logix Designer – Allen Bradley PLCs / Zyggot Relays Connection. Let's consider that we have only 5 RADDIA TS temperature sensors.

1- OPEN YOUR PROJECT

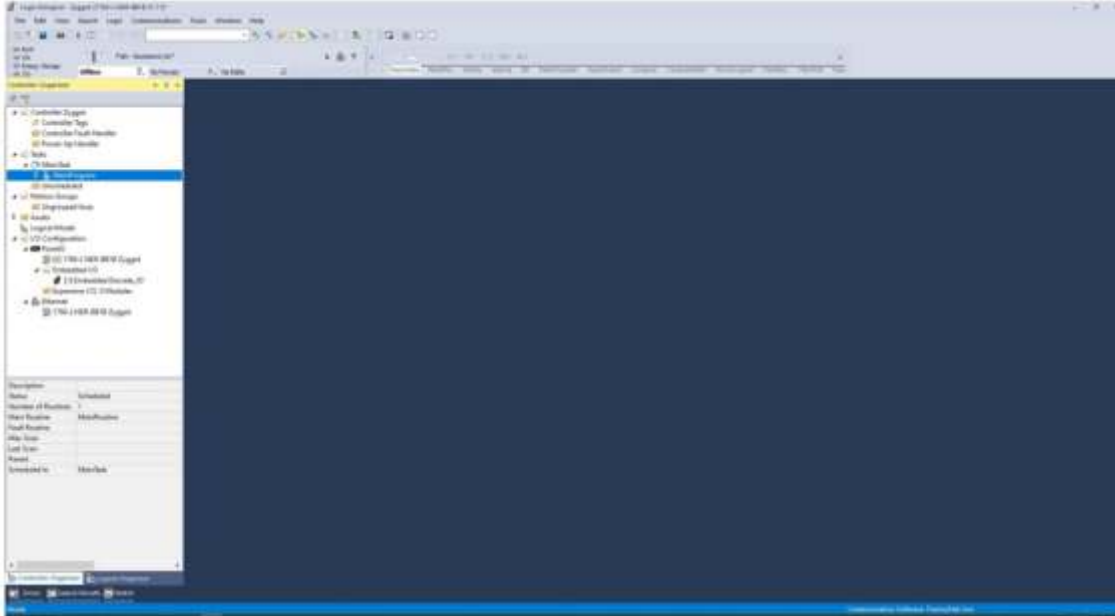

2- RIGHT CLICK ON "ETHERNET" AND THEN CLICK ON "NEW MODULE..."



MODBUS OVER ETHERNET TCP IP SERVER

ETHERNET MODULE IN STUDIO 5000/LOGIX DESIGNER ALLEN BRADLEY

Steps to create an Ethernet module in a project in Studio 5000/Logix Designer – Allen Bradley PLCs / Zyggot Relays Connection. Let's consider that we have only 5 RADDIA TS temperature sensors.

3- IN THE “SELECT MODULE TYPE” WINDOW, SELECT THE “CATALOG” TAB AND TYPE “GENERIC” IN THE SEARCH FIELD.

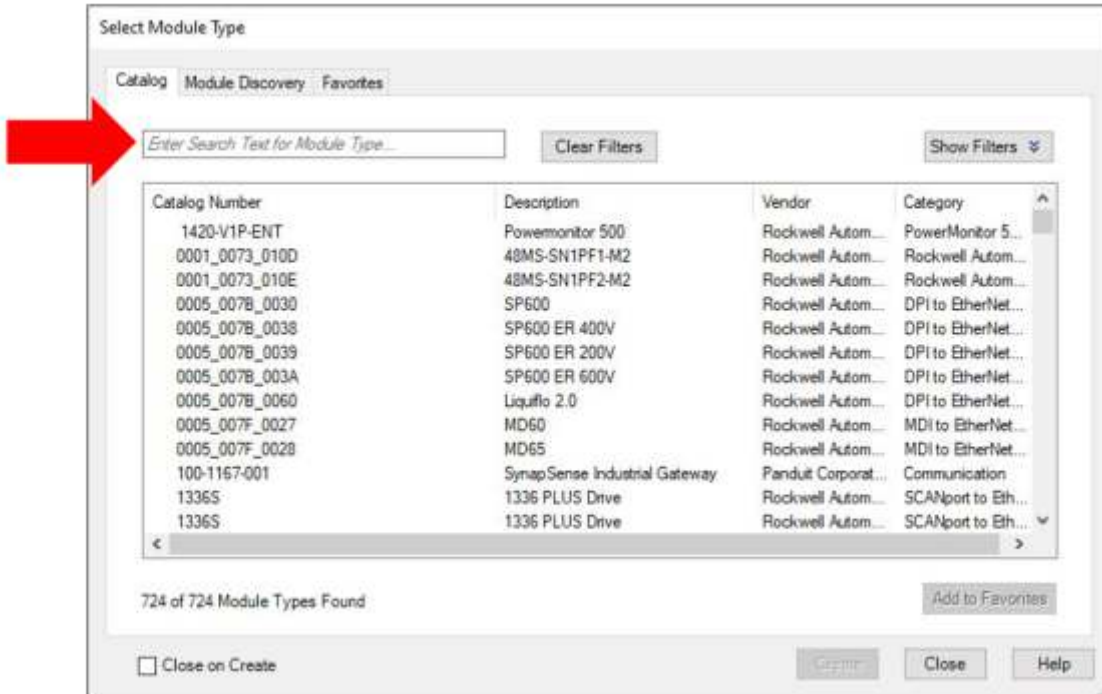

4- THEN SELECT “ETHERNET-MODULE” AND CLICK “CREATE”

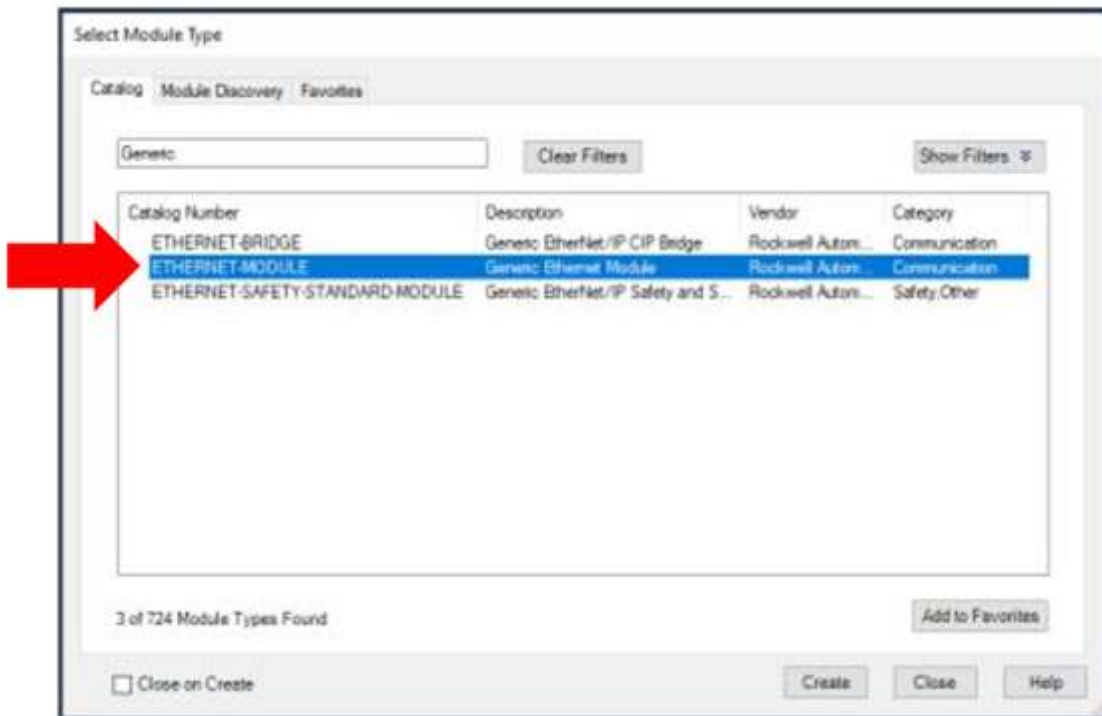

MODBUS OVER ETHERNET TCP IP SERVER

ETHERNET MODULE IN STUDIO 5000/LOGIX DESIGNER ALLEN BRADLEY

Steps to create an Ethernet module in a project in Studio 5000/Logix Designer – Allen Bradley PLCs / Zyggot Relays Connection. Let's consider that we have only 5 RADDIA TS temperature sensors.

5- IN THE “NEW MODULE” WINDOW:

- IN THE “COMM FORMAT” FIELD, CHOOSE THE “DATA – INT” OPTION
 - IN “IP ADDRESS”, ENTER THE IP THAT WAS CONFIGURED IN THE ZYGGOT RELAY
 - IN “ASSEMBLY INSTANCE” OF THE INPUT, ENTER “100”
 - IN “SIZE” INPUT, ENTER “128”
 - IN “ASSEMBLY INSTANCE” OUTPUT, ENTER “101”
 - IN “SIZE” OUTPUT, ENTER “128”
 - IN “ASSEMBLY INSTANCE” CONFIGURATION, ENTER “3”
 - IN “SIZE” CONFIGURATION, ENTER “0”
- THEN CLICK “OK”.

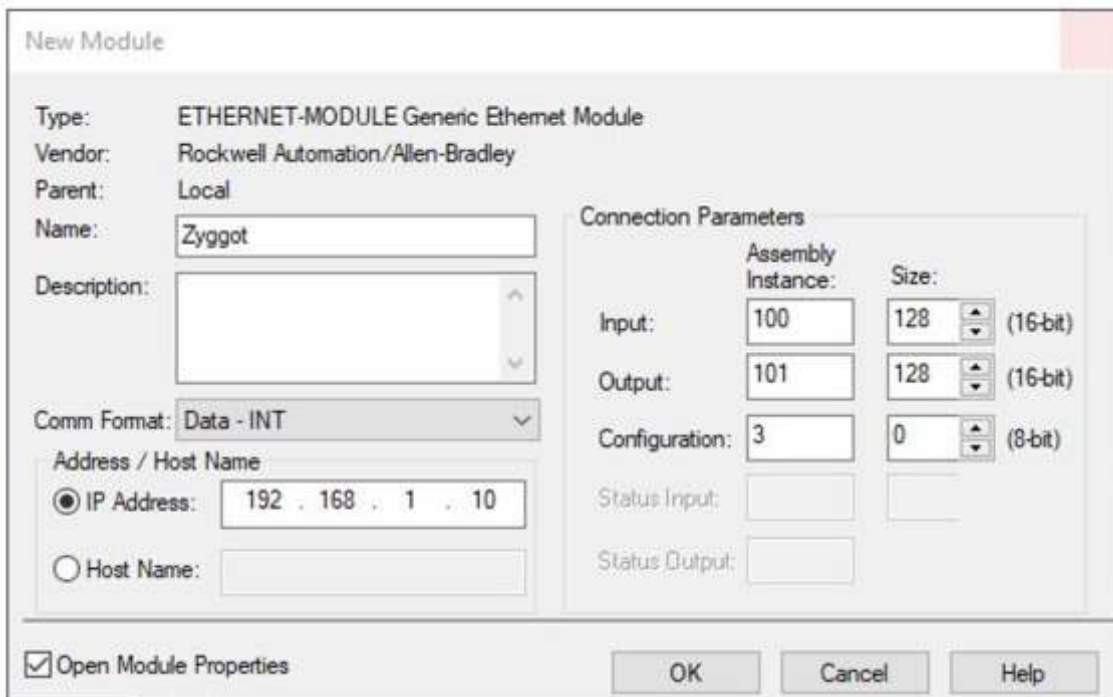

New Module

Type: ETHERNET-MODULE Generic Ethernet Module
 Vendor: Rockwell Automation/Allen-Bradley
 Parent: Local
 Name: Zyggot
 Description:
 Comm Format: Data - INT
 Address / Host Name
 IP Address: 192 . 168 . 1 . 10
 Host Name:
Connection Parameters
 Input: Assembly Instance: 100, Size: 128 (16-bit)
 Output: Assembly Instance: 101, Size: 128 (16-bit)
 Configuration: 3, Size: 0 (8-bit)
 Status Input:
 Status Output:
 Open Module Properties
 OK Cancel Help

MODBUS OVER ETHERNET TCP IP SERVER

ETHERNET MODULE IN STUDIO 5000/LOGIX DESIGNER ALLEN BRADLEY

Steps to create an Ethernet module in a project in Studio 5000/Logix Designer – Allen Bradley PLCs / Zyggot Relays Connection. Let's consider that we have only 5 RADDIA TS temperature sensors.

6- DOWNLOAD THE PROJECT TO THE PLC.

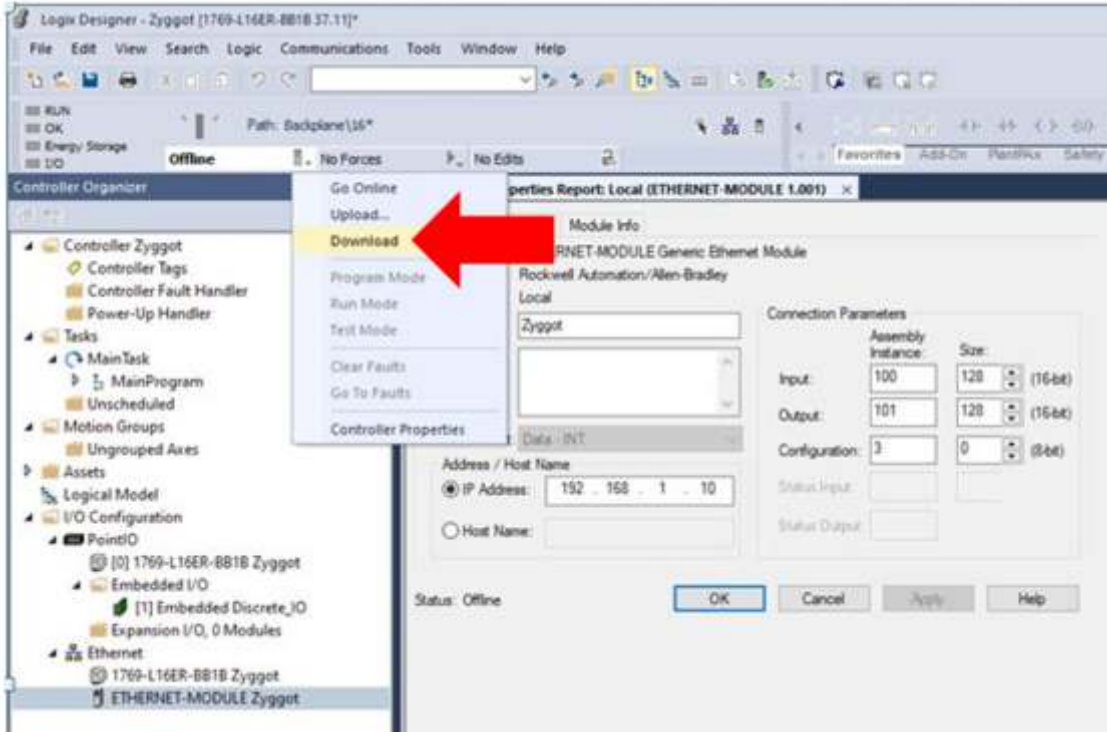

7- TESTING: READING THE TARGET TEMPERATURE OF THE 5 SENSORS CONNECTED TO THE RELAY.

7a- LEAVE THE PLC IN RUN MODE BY THE SYSTEM AND DOUBLE CLICK ON “CONTROLLER TAGS”.

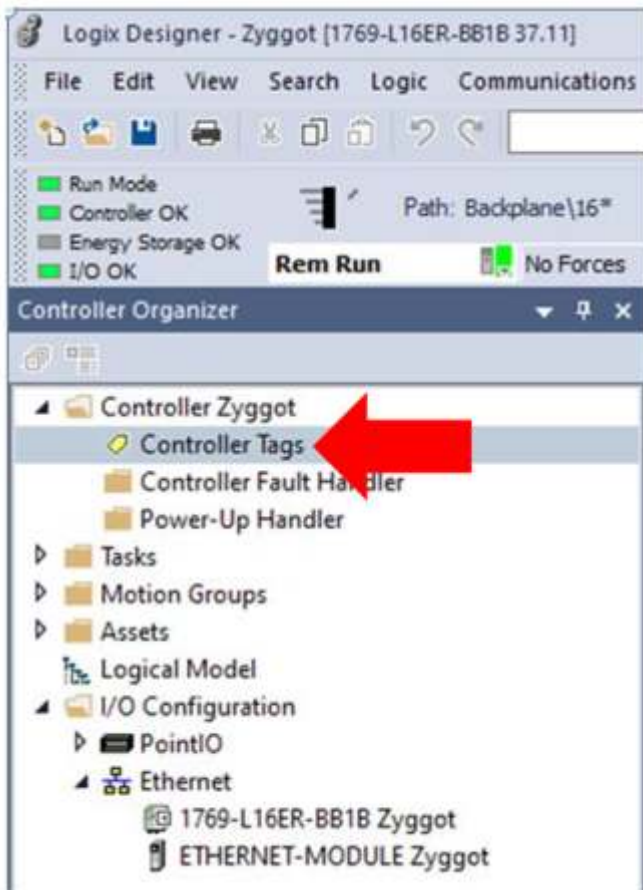

MODBUS OVER ETHERNET TCP IP SERVER

ETHERNET MODULE IN STUDIO 5000/LOGIX DESIGNER ALLEN BRADLEY

Steps to create an Ethernet module in a project in Studio 5000/Logix Designer – Allen Bradley PLCs / Zyggot Relays Connection. Let's consider that we have only 5 RADDIA TS temperature sensors.

7b- SELECT AS SHOWN.

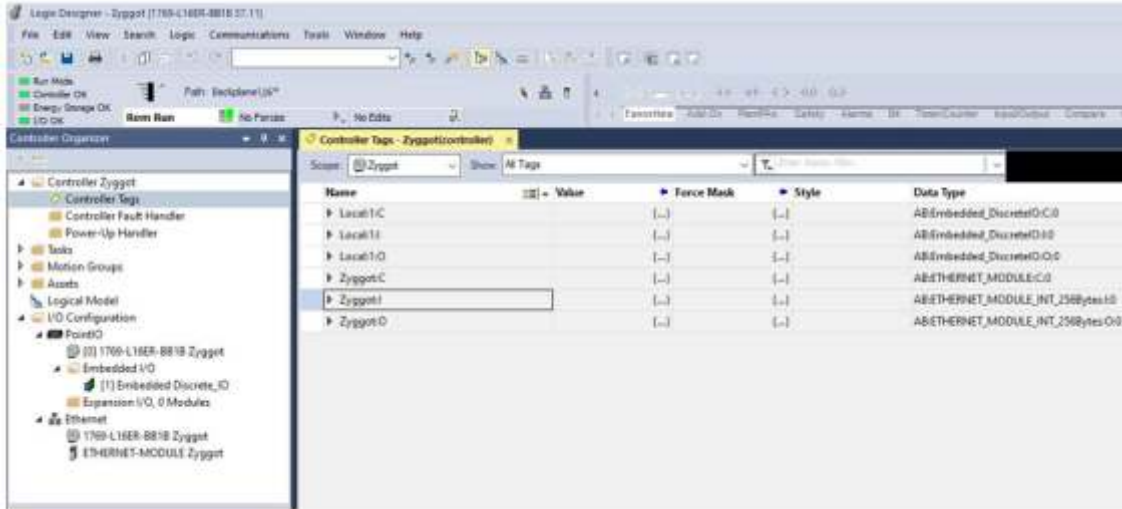

7c- FIND THE OUTPUT RECORD “...O.DATA[126]” (%R3327) AND MAKE SURE IT HAS THE VALUE “1,” OTHERWISE, ASSIGN IT THE VALUE “1” (THIS WILL SELECTE PAGE 1, THIS «PAGE» IS REFERENT TO THE SYSTEM TARGET TEMPERATURE VALUES).

| | | | |
|--------------------|---|---------|-----|
| Zyggot:O.Data[120] | 0 | Decimal | INT |
| Zyggot:O.Data[121] | 0 | Decimal | INT |
| Zyggot:O.Data[122] | 0 | Decimal | INT |
| Zyggot:O.Data[123] | 0 | Decimal | INT |
| Zyggot:O.Data[124] | 0 | Decimal | INT |
| Zyggot:O.Data[125] | 0 | Decimal | INT |
| Zyggot:O.Data[126] | 1 | Decimal | INT |
| Zyggot:O.Data[127] | 0 | Decimal | INT |

7d - NOW FIND THE INPUT REGISTER “...I.DATA[0]” (%R2801), DIVIDING THE RECEIVED VALUE BY 10, WE WILL HAVE THE TARGET TEMPERATURE OF SENSOR 1. IN THE REGISTER “...I.DATA[1]” (%R2802) WE HAVE THE TARGET TEMPERATURE OF SENSOR 2 AND SO ON. IN THE IMAGE BELOW WE HAVE THE TEMPERATURE VALUES OF THE FIRST 5 SENSORS READ BY THE RELAY (NOT YET DIVIDED BY 10).

| Name | Value | Force Mask | Style | Data Type |
|------------------|-------|------------|-------|-------------------------------------|
| LocalI:C | [...] | [...] | [...] | AB:Embedded_DiscreteI:O:C:0 |
| LocalI:I | [...] | [...] | [...] | AB:Embedded_DiscreteI:O:I:0 |
| LocalI:O | [...] | [...] | [...] | AB:Embedded_DiscreteI:O:O:0 |
| Zyggot:C | [...] | [...] | [...] | AB:ETHERNET_MODULE:C:0 |
| Zyggot:I | [...] | [...] | [...] | AB:ETHERNET_MODULE_INT_256Bytes:I:0 |
| Zyggot:I.Data | [...] | [...] | [...] | INT[128] |
| Zyggot:I.Data[0] | 233 | | | Decimal INT |
| Zyggot:I.Data[1] | 232 | | | Decimal INT |
| Zyggot:I.Data[2] | 224 | | | Decimal INT |
| Zyggot:I.Data[3] | 211 | | | Decimal INT |
| Zyggot:I.Data[4] | 245 | | | Decimal INT |
| Zyggot:I.Data[5] | | | | Decimal INT |
| Zyggot:I.Data[6] | 0 | | | Decimal INT |
| Zyggot:I.Data[7] | 0 | | | Decimal INT |
| Zyggot:I.Data[8] | 0 | | | Decimal INT |
| Zyggot:I.Data[9] | 0 | | | Decimal INT |

ABOUT VARIXX

For over 40 years, Varixx has pursued its vocation for developing high-tech products and focuses its efforts on serving the industrial market with quality and speed. Our know-how in power electronics has allowed us to offer the market a wide range of products that have become known for their long service life and reliability. We were the creators of the global online thermography market, with the Zyggot line, which is becoming a global reference in the market for temperature monitoring and diagnostics and arc flash detection in electrical systems in general.

Our product portfolio also includes LED luminaires from our ONNO division, developed and manufactured 100% in house with cutting-edge technology. Varixx values the introduction of innovative concepts worldwide.

AREAS OF ACTIVITY

- ✓ **MANUFACTURERS OF GENERATOR MACHINES AND SYNCHRONOUS MOTORS**
Static Exciters, Control Box Controllers, Low and Medium Voltage Soft Starters, Semiconductors and Onno LED Luminaires.
- ✓ **ALUMINUM AND HYDROGEN / OXYGEN PRODUCTION**
High Current Rectifiers, Solid State Contactors, Smart Relay for CCM, Online Thermography System and Arc Flash Detection and Onno LED Luminaires.
- ✓ **BASE INDUSTRY, MINING AND STEEL**
Smart Relays for CCMs, Low and Medium Voltage Soft Starters, Solid State Contactors, AC/DC Converters for Electromagnets, High Current Rectifiers, Online Thermography System, Arc Flash Detection and Protection and Onno LED Luminaires.
- ✓ **OIL COMPANIES**
Smart Relays for CCMs, Static Excitation, Low and Medium Voltage Soft Starters, Solid State Contactors, Online Thermography System, Arc Flash Detection and Protection and Onno LED Luminaires.
- ✓ **PANEL BUILDERS**
Smart Relays for CCMs, Online Thermography, Arc Flash Detection and Protection Systems, Semiconductors, Power Supplies and Onno LED Luminaires.

Also check out ZYGOT Tube Network Thermography



**SINGLE CABLE /
EASY TO INSTALL**



**PREDICTIVE /
DIFFERENTIAL PROTECTION**



**COMPLIANCE WITH
SAFETY STANDARDS**



**PREVENTS OPENING
OF THE PANEL / PREVENTS
CATASTROPHIC FAILURES**



**DOES NOT NEED
CONVENTIONAL
THERMOGRAPHY /
ALSO MEASURES AIR TEMP.**



**WITHOUT CONTACT /
NETWORKED
COMMUNICATION**

LEARN MORE!



ZYGGOT ARC

ARC FLASH PROTECTION SYSTEM

- ✓ **Low Cost // Up to 50 sensors per relay.**
- ✓ **Innovative in the market // Faster (300 uS)**
- ✓ **Ultraviolet arc detection**
- ✓ **Does not operate with ambient light (False Alarm)**
- ✓ **No need for current reading**

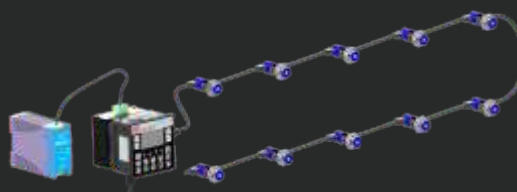

United States - Houston, TX

2929 Allen Parkway, Suite 200, Houston, 77019

☎ +55 (19) 3301-6900

Brasil - Piracicaba, SP

Rua Felipe Zaidan Maluf, 450 - Distrito Industrial Unileste

☎ +55 (19) 98124-6974 // (19) 3301-6900

✉ vendas@varixx.com

WORLDWIDE

Distributors and Representatives in more than 15 countries

varixx

ALWAYS AN ORIGINAL IDEA



@Varixxbrasil



@varixxcompany



Varixx Indústria Eletrônica



www.varixx.com
www.varixx.com.br

Representative/Distributor:

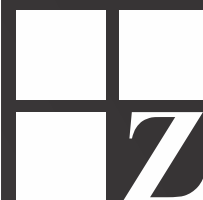

ZYGGOT THERMOGRAPHY