

varixx

Our Solutions

Protection and Monitoring

Online Thermography System
Electric Arc Protection System
Motor Protection

Excitation Systems

Excitators for Synchronous Generators
Exciters for Synchronous Motors
Protection for Excitation Systems

Complete Systems

Motor Drive Systems
Load Drive Systems
Electromagnet Drive Systems
Excitation Systems for Motors
and Synchronous Generators
High Power Rectifiers

Driving Loads

Motor Drives
Capacitor Bank Drive
Driving Electromagnets
Driving Resistive and Inductive Loads

AC/DC Converters and Rectifiers

AC/DC Converters
Switched Power Supplies
High Power Rectifiers
Semiconductors

LED Lighting Solutions

Highbay (Pending)

Designed for lighting large
industrial spaces with high ceilings

Projector (Reflector)

Directional lighting for all types of
indoor and outdoor environments

GAP (Embed)

Ideal for embedding in industrial
and commercial ceilings

Indoor and Outdoor Agriculture

Suitable for agriculture in controlled
indoor and outdoor environments

Rail (Cable Tray)

Ideal for installations directly on
profiles and cable trays

Downlight (Overlay)

Ceiling and ceiling mounted
lighting

Street (Post)

To be fixed to poles in external
commercial areas and public
spaces

Special Applications

For electrical panels and more

Consolidating innovations for almost half a century

Founded in 1976, Varixx is a Brazilian company known for developing technological solutions in the field of power electronics and sensitive electronics, with products developed and manufactured entirely in Brazil and, more recently, distributed in the United States to serve various regions more quickly.

It has built a solid reputation as an innovative company based on its know-how in constant development, backed by numerous technological patents and pioneering products.

Varixx is also recognized for the exceptional robustness and durability of its products, as it serves critical sectors such as petrochemical, hydroelectric, steel, mining, data centers, chemical, among others, where safety and reliability are essential.

It is worth highlighting the after-sales service, a source of pride that reflects a serious commitment to its customers. In addition, 100% vertical production ensures lead time and excellence in quality.



World Pioneer in Online Thermography and UV Arc Detection

In 2004, Varixx pioneered the development of the world's first Online Network Thermography System for Continuous Temperature Monitoring for electrical panels.

Since then, it has maintained its position at the forefront of technology, being also the first and, to date, the only company to manufacture an Electric Arc Protection system based exclusively on ultraviolet (UV) radiation detection, eliminating the need for light and electrical current measurement.

With a consolidated presence on every continent, Varixx stands out as a global benchmark in innovation, offering solutions that comply with standards establishing modern maintenance and safety practices in electrical installations.

ZYGGOT® THM+ARC

Developed to meet growing demands for reliability and safety standards in electrical systems, it integrates two well-known Varixx systems: ZYGGOT® Temperature (Continuous Thermographic Monitoring) together with the ZYGGOT® Arc system (Electric Arc Detection and Mitigation).

ZYGGOT® THM+ARC combines the best of both technologies in a single relay, offering financial savings, space savings, extreme safety, and robust protection.



Characteristics



Continuous monitoring (24/7) of up to 100 non-contact temperature sensors via relay



Acts in less than 250µs in the pre-arc phase (before visible light)



Effectively reduces incident energy compared to light and current detection systems



Color touch screen with a modern, user-friendly interface (over 200 screens)



Ethernet and Modbus RTU communication



Up to 100 arc sensors per gateway (up to 40 gateways)

Supports up to 40 gateways, with 100 arc sensors per gateway, providing wide coverage and high detection efficiency.

The multi-gateway version of ZYGGOT® THM+ARC enables highly accurate arc selectivity, which is essential for independently and controlled tripping of circuit breakers. Each panel compartment can be equipped with a dedicated, cost-effective gateway, while a single central relay manages the entire system.

Available in Mono and Multi-Gateway versions, the system easily adapts to different industrial architectures, making it ideal for use in substations, motor control centers (MCCs), transformers, data centers, and critical electrical installations.

Integrated Sensors (Arc + Temperature)



UV Sensor



Tubular Sensor

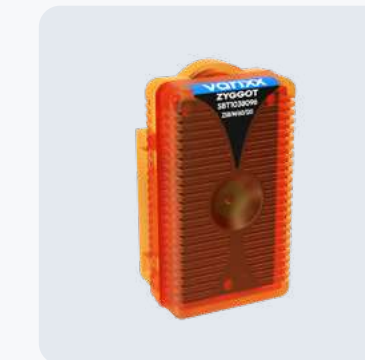

LV Sensor

ZYGGOT® SG

Developed as a complement to Varixx's ZYGGOT® family of solutions, offering continuous, real-time monitoring of temperatures in internal or external connections of MCC and Data Center drawers, as well as shielded Busbar-type busbars.

ZYGGOT® SG provides easy installation, high reliability, and low cost.



Smart digital sensors with a capacity of up to 400 sensors per gateway

It has smart digital sensors with a capacity of up to 400 sensors per gateway, connected in a "One Wire" network, with automatic detection and addressing, encapsulated in high-temperature polycarbonate and powered directly by the network itself.

If one sensor fails, the others continue to operate normally, ensuring the reliability of the system, which has two types of sensors: Single Port and Dual Port.

Dual Port sensors allow for cascading connections, supporting up to 50 sensors per gateway port and cables up to 300 meters long, providing scalability and flexibility for a variety of applications.

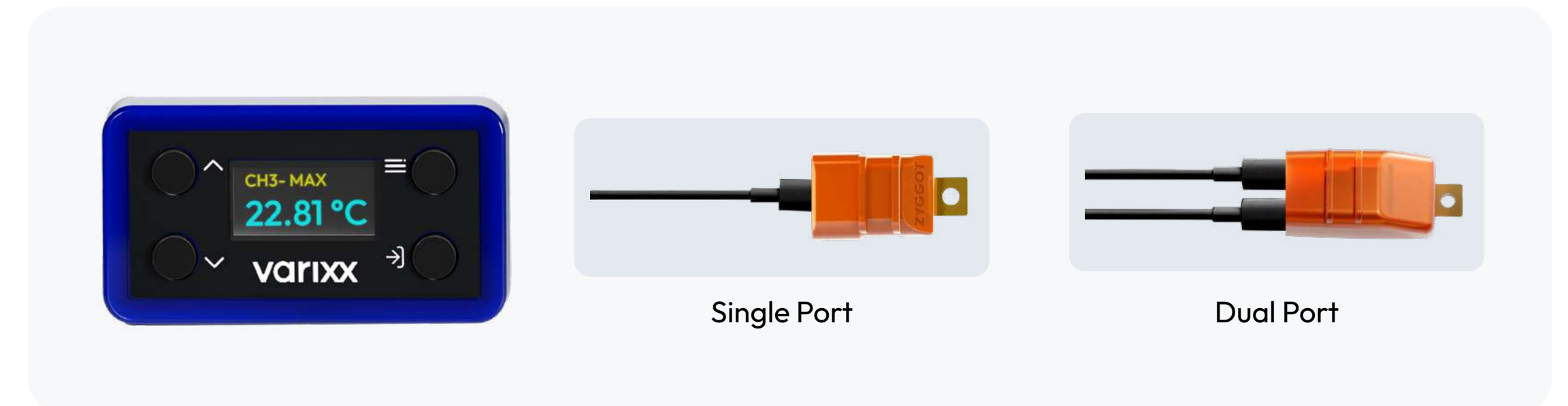

Characteristics



Thermographic monitoring for MCC, Data Center, Busbar, etc



Modbus RTU (RS-485) and Ethernet communication



Compatible with Busbar type shielded busbars



Serial connection of up to 400 sensors per gateway, with dual-port sensors



One Wire network



Display for real-time monitoring

ZYGGOT® Raddia TS

It offers continuous, real-time monitoring of temperatures in low, medium, and high voltage internal components and connections, such as transformers, motors, and electrical panels, using radio signal transmission technology, without the use of batteries.

With its wide versatility, the system is compatible with applications ranging from low voltage to high voltage (35 kV or more), and can be used in cubicles of any type.



Monitoring of up to 125 sensors per relay

Capable of monitoring up to 125 sensors per relay, Raddia TS ensures comprehensive coverage with configurable alarms and triggers that optimize electrical system protection.

Its radio data transmission at 433 MHz or 470 MHz frequencies allows for quick and easy installation.

Communication and Programming

It has an Ethernet communication interface, allowing remote access from any location with network connectivity. Several industrial communication protocols are incorporated into the device, enabling activation and configuration directly from the equipment's parameterization screens.



Characteristics



Easy to install, no batteries required (battery-powered sensors can be supplied as an option)



Operates powered by bus current from 5a



Reading and protection of up to 125 points per relay



Modbus and Ethernet communication



Transmission of signals by radio



Failure and action history with Real Time Stamp

ZYGGOT® TOH

Integrated Continuous Temperature + Ozone + Humidity Monitoring System, creating a complete predictive solution that addresses the three most critical variables that directly influence arc formation: temperature, humidity, and ozone concentration.

All readings can be accessed remotely anywhere in the world, thanks to Modbus and Ethernet communication available on the system relay.



ZYGGOT® TOH is equipped with sensors for low, medium, and high voltage panel applications.

It integrates ultrasensitive ozone sensors capable of detecting concentrations ranging from 0 to 2000 parts per billion (ppb), in addition to sensors for measuring relative humidity. Each relay can monitor up to 125 temperature sensors or combined ozone and humidity sensors, monitoring the supply voltage of each one, facilitating the detection of possible network failures.

It is worth remembering that systems with compromised or aged insulators have a high rate of partial discharges and corona, which result in increased ozone (O³) generation.

Integrated Sensors



Characteristics



Detects aging of components and insulators



Selectivity with independent alarms for accurate fault identification



Advanced technology for accurate and ultrasensitive ozone detection



Monitoring of target and ambient temperatures to identify gradient differences



Ozone and humidity sensors detect insulation degradation and heating or ventilation failures



A single relay monitors 4 variables in up to 100 sensors and 250 measurements

Discover some of the products by VARIXX



ZYGGOT® SG TF
(Transformers)



ZYGGOT® Raddia TF
(Transformers)



ZYGGOT® Temperature



ZYGGOT® Arc



ZYGGOT® Arc SPL



ZYGGOT® Arc
(Touch Screen)



Discover some of the products by VARIXX

Complete Systems

Varixx is a benchmark in the creation of complete and unique systems on the market. Our drive and excitation products, among others, are designed for a wide range of applications, with sizes and parameters modulated to meet customer needs.



Solid-State Contactor (Solidvar)



AC/DC Converter for Electromagnet (Mag-V)



Power Controller (MykrOn)



Online Digital Battery Bank charger (Mobatt)



Complete AC/DC Converter System for Electromagnets (CM-VRT)

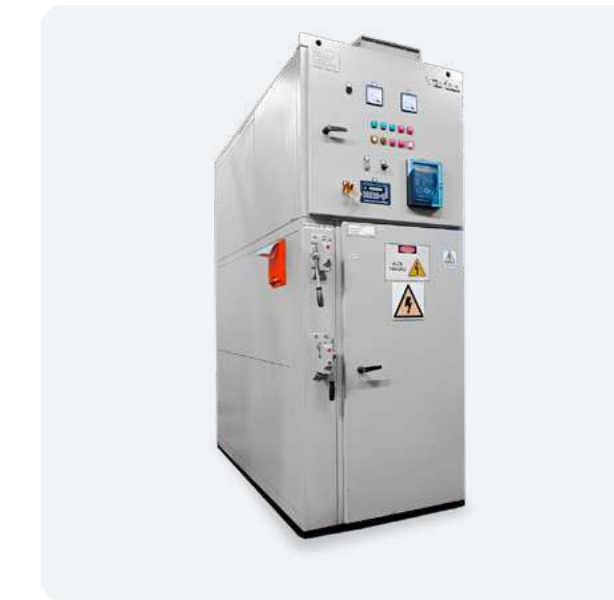

Control and Excitation Systems for Medium Voltage Motors (Poweramp)



Complete Power Control Systems (Hyamp)



Digital Excitation Systems for Synchronous Motors and Generators



Synchronism Controller for Synchronous Motors (Control Box)



AC/DC Converter for Brakes (VRF)

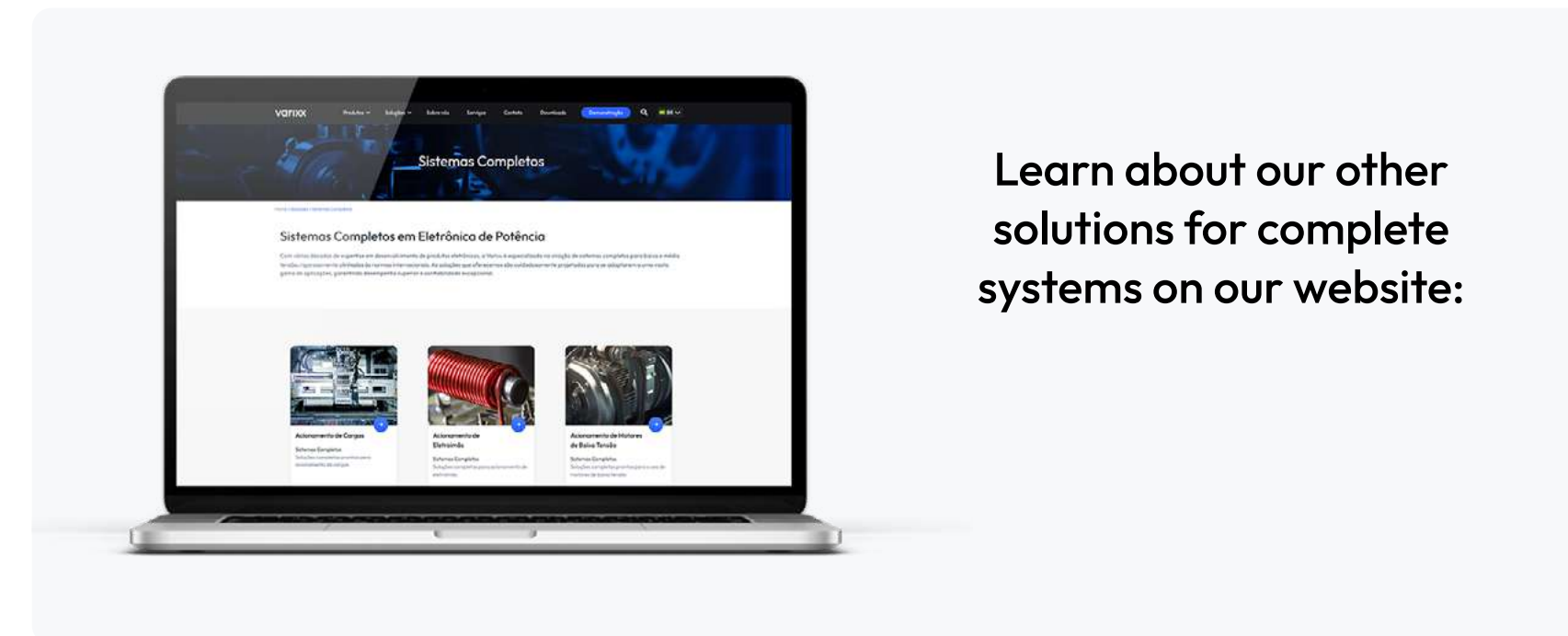

Learn about our other solutions for complete systems on our website:

ONNO LED

Varixx's ONNO LED line is designed for large industries and commercial establishments, offering innovative and robust solutions that combine energy efficiency, high light quality, and exceptional durability.

With the energy of a young brand and Varixx's nearly 50 years of experience, ONNO LED luminaires stand out technologically, being entirely designed and produced vertically in Brazil.

In addition, the luminaires have a long service life of over 100,000 hours, reducing the need for frequent maintenance and allowing for retrofitting, which lowers costs and contributes to more sustainable operations.

Lighting Line ONNO LED



**Highbay
(Pending)**



**Projector
(Reflector)**



**GAP
(Embed)**

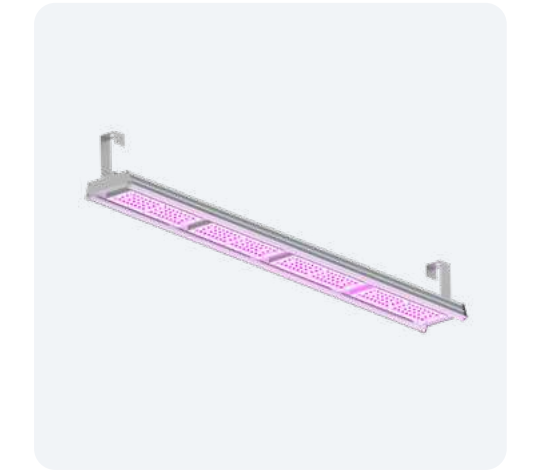

**Indoor and Outdoor
Agriculture**



**Rail
(Cable Tray)**



**Downlight
(Overlay)**



**Street
(Post)**

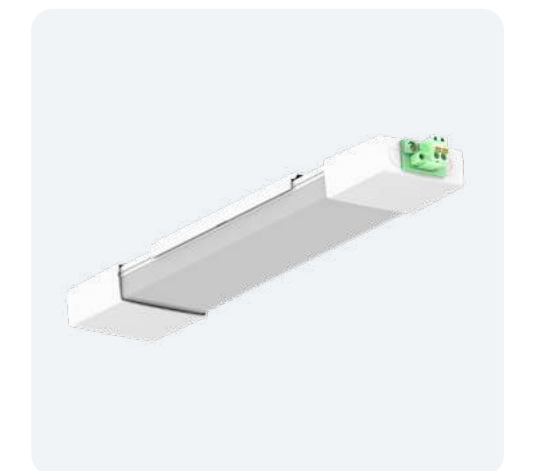

**Special
Applications**



Visit our website to learn
more about our products

 +1 (281) 905-6834

 +1 (832) 871-5704

 sales@varixx.com

 [varixx.com/en](https://www.varixx.com/en)

 <https://www.linkedin.com/varixx>

varixx