



ZYGGOT ARC SPL

LOW COST ULTRAVIOLET ARC FLASH PROTECTION SYSTEM

ARROW SPL

HYPER FAST ULTRAVIOLET ARC FLASH PROTECTION SYSTEM



W/ ETHERNET

ZYGGOT ARC SPL

LOW COST ARC FLASH PROTECTION SYSTEM



Ultraviolet Arc Tubular Sensors with 90° viewing angle

DESCRIPTION

Varixx was the world's pioneer in introducing a Continuous, Online, Networked Temperature Monitoring System in 2004 and is a market leader in this area.

Later, it introduced the world's first ultraviolet arc detection system with the ZYGGOT ARC family, with a dedicated relay, supporting the connection of up to 50 arc sensors. It recently introduced the first continuous temperature monitoring system integrated with an ultraviolet arc protection system with multiple triggering Gateways providing high selectivity, with the use of one Gateway per circuit breaker to be tripped in the event of an arc, called THM+ARC. The system described in this manual, called ZYGGOT ARC SPL, was derived from this system.

The low-cost ZYGGOT ARC SPL system was designed to provide protection against ARC FLASH, with high selectivity, with the world's best technology for detecting and protecting against electric arcs, using ultraviolet light (Patent PI 0903809-4), which enables a reduction of up to 150 times in incident energy, compared to systems that detect visible light and current.

Sensors with 90° opening angles allow monitoring of an entire cubicle with a single sensor, since their high sensitivity allows detection of the beginning of an electric arc even at points outside their viewing angle or hidden by equipment, thanks to the reflection of UV radiation on the internal walls of the panel.

The Ultraviolet detection mode does not require confirmation of current increase and inhibits the formation of an arc at its beginning due to its extremely fast action (<250 µs), detecting the arc in its initial phase and not in the fourth phase of the arc, unlike existing systems that detect light and current, which only reduce the effect of the arc, already formed, thus reducing the incident energy by around 80 to 150 times compared to the competition. It is a system that has already been widely approved, with hundreds of real

cases of detection and actuation, with minimal or no damage to the protected systems, with a return time of minutes to a few hours.

In addition, since it does not require current monitoring, it is very easy to implement and costs much less than light and current detection systems.

The system presented in this manual is in addition to the independent THM and Arc Flash systems, which continue in the product portfolio, with Modbus and Ethernet communication and several additional programming and protection features. The ZYGGOT ARC SPL system provides efficient protection against electric arcs in equipment that does not allow for high implementation costs. Its particularity is that it does not include a dedicated relay, which is expensive, but it still offers the possibility of interconnecting via Modbus to the user's SDSD system, with each triggering Gateway being able to monitor up to 50 arc sensors.



APPLICATION

Low-cost Arc Flash Protection.

BENEFITS

- * Arc detection in phase 1 (pre-arc).
- * Reduction of incident energy between 80 and 150 times compared to the competition.
- * Indicates any faulty sensor.
- * Fault history.
- * Modbus communication

System Features

- * Applicable to low and medium voltage.
- * Up to 50 UV arc sensors in RS485 network with mini USB connections.
- * Smart Sensors powered by the network itself.
- * 90° measurement angle for Arc.
- * Fault history with "Time Stamp".
- * Arc Flash Protection with Gateway independent triggers and up to 50 Arc sensors for Ultraviolet detection per Gateway.
- * External fault monitoring.
- * Sensor status monitoring.
- * 2 programmable digital outputs per Gateway
- * Each sensor has a flashing LED and can be controlled by Modbus to facilitate its location and address on the network and integrity verification.
- * Open Modbus address map.

KEY POINTS

Main Advantages

- WORLD'S MOST ADVANCED ARC PROTECTION
- HIGH SELECTIVITY FOR ARC (MULTI GATEWAY)
- ARC ACTUATION IN LESS THAN 250uS
- REDUCES INCIDENT ENERGY BY UP TO 150X
- DISPENSES CURRENT MEASUREMENT FOR ARC
- CAN DETECT UV AT NON-VISIBLE POINTS
- DOES NOT USE BATTERIES
- PROVEN RELIABILITY
- HISTORY OF EVENTS
- WORLD LEADING SYSTEM

The ZYGGOT ARC SPL system, with stainless steel tubular sensors, was developed for low and medium voltage panels. The sensors detect UV radiation in the first phase of the arc, without physical contact, and allow local and online protection for up to 50 sensors per Gateway. The sensors are connected to a high-speed CAN network using mini USB cables in sizes from 0.3 to 8.0 meters (supplied), which allows for quick, error-free installation without tools. The Gateway provides local protection and also through a supervisory system. A possible failure in one of the sensors does not interrupt the operation of the other sensors. The Gateways are connected to each other via a Modbus network and this network is also accessible by the user's DCS system if they wish to interconnect with the plant protection system.

KEY POINTS

- Arc flash protection by UV, the most advanced in the world (Patent No. PI 0903809-4).
- Reduces incident energy by up to 150x compared to systems by light and current detection.
- Dispenses with current measurement for arc flash confirmation.
- Multi Gateways allow high selectivity for arc tripping, using a low-cost triggering Gateway per cubicle or per associated circuit breaker.
- Event history.
- Modbus RTU communication.
- Each Gateway can receive up to 50 arc sensors.
- Continuous measurement of supply voltages from each arc sensor (allowing monitoring of network integrity).

APPLICATIONS

- Internamente a painéis para proteção contra arco voltaico.
- Supervisão de subestações.

MAIN FEATURES

- Reads the sensor's power supply voltage.
- Up to 50 arc sensors per Gateway.
- Monitors Arc Flash by UV detection.
- Dispenses with current measurement for arc confirmation.
- Actuation in less than 250uS, in the pre-arc phase, reduces the incident energy by up to 150x in relation to systems by light and current detection.
- Multi Gateways allow high selectivity for arc, allowing each circuit breaker to be tripped independently of the others, using a low-cost gateway per cubicle.
- Event history.
- 2 configurable digital inputs per Gateway.
- 2 configurable digital outputs per Gateway.
- Dedicated high-speed static contact trip output for tripping the circuit breaker associated with the Gateway + dry contact output for tripping other systems.
- Modbus RTU.

TOPOLOGY DESCRIPTION.

Each sensor has an LED that flashes under Modbus command to facilitate diagnosis and check the addressing and integrity of the system. Each relay can monitor up to 50 ARC SPL sensors. Each Gateway monitors the supply voltage level reaching each sensor, allowing the detection of potential problems in the network, such as cabling exceeding the permitted length. The low-cost SPL ultraviolet arc sensors are connected through 1 independent, low-cost Gateway, allowing selectivity never before available worldwide for the tripping of specific circuit breakers in each cubicle. The Gateway has the function of tripping the associated circuit breaker in the event of an arc flash, memorizing the arc flash sequence, sensor status, such as supply and communication voltages. Two digital inputs and two digital outputs are also available on each Gateway, allowing tripping or alarm due to external fault or arc chaining, tripping multiple circuit breakers in the event of an arc flash downstream. The data transmission method between sensors and Gateway uses high-speed CAN physical layer communication, with all sensors connected in parallel using shielded cables with mini-USB connectors that allow quick installation and operation without the need for any tools. Each Gateway of the Zyggot SPL system can be connected to a Modbus communication network with a supervisory system or remote monitoring.

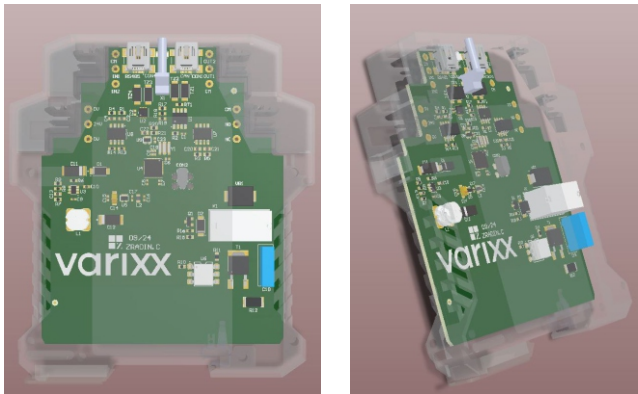

Construction detail of the Gateway

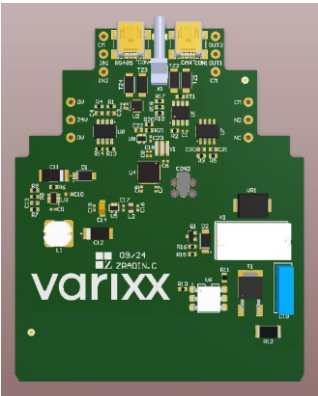

Gateway ZYGGOT ZAG1R/L.

- **Saidas Digitais:** 02 Programmable.
- **Parameter programming:** By «Superger» software (free) or Modbus.
- **Value reading:** Supply voltage of each ARCO sensor.
- **Communication:** RS485 serial MODBUS RTU protocol for “Point to Point” connection, for use in network (Droop Out). CAN port for sensor network.
- **Protections and indications:** Modbus communication failure, Arc sensors not responding, Arc Flash trip, Alarm due to Gateway not programmed correctly, Alarm or trip due to ARC Chain, Alarm and Trip due to external fault, Status of digital inputs and digital outputs.
- **Digital Input 1:** Programmable in «None», «Reset».
- **Digital Input 2:** Programmable in «None», «Reset», «Inhibit / Disable Out Trip», «Chain».
- **Real Time Clock:** Included, Synchronized by Modbus.
- **Fault History:** with Date and Time.
- **Event Memorization:** 50 latest events, memorized indefinitely, with the most recent ones erasing the oldest ones.
- **Programmable Digital Output 1:** «Trip», «Armed», «Alarm», «Remote 1”.
- **Programmable Digital Output 2:** «Trip», «Armed», «Alarm», «Remote 2”.
- **Parameter programming:** By PC software (Free), or by Modbus.

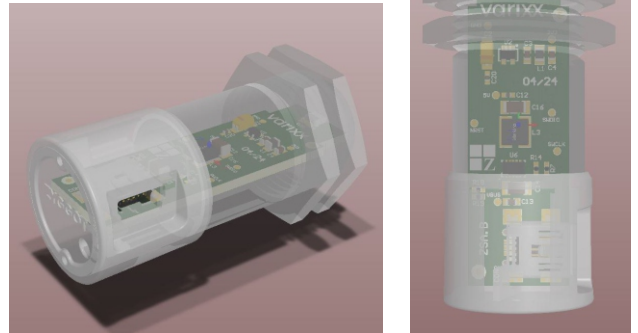

Construction detail of the Sensor

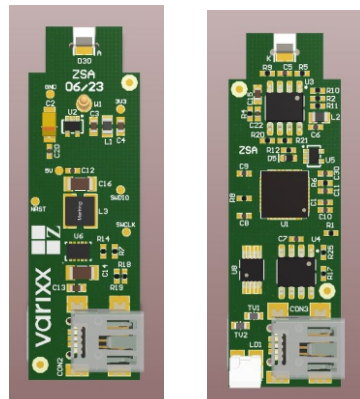

TECHNOLOGY AND MAIN FEATURES OF THE ZYGOT ARC SPL LOW COST ARC SYSTEM

The low-cost ZYGOT ARC SPL Arc Flash Protection System was developed as a derivative of the standard Zyggot ARC systems with dedicated relay, plus the THM+ARC system with dedicated relay and integrated with the continuous temperature monitoring system. The low-cost ZYGOT ARC SPL system provides the most efficient full-time arc flash protection available worldwide for low and medium voltage electrical equipment such as panels, transformers, motors and generators.

The ZYGOT Arc Flash Protection System in its various versions introduces an important innovation to the market due to the fact that it detects ultraviolet (UV) radiation at the beginning of the arc, i.e., the pilot path, in phase 1 of the arc, before the detection of light from other systems. The light phase is already the final phase of the arc, with expansion of gases and vaporization of copper and other metals. Another important advantage is that selective monitoring of ultraviolet radiation eliminates the need for simultaneous monitoring of the current to confirm the occurrence of the arc, which visible light detection systems require.

If ultraviolet radiation is emitted at certain levels, the system can be safely tripped. Systems that detect visible light could be activated by door openings or light entering through cracks, which requires simultaneous current monitoring to prevent inadvertent tripping.

The ZYGOT Arc Flash Protection System, unlike light detection systems, can be applied even under direct sunlight, thus opening up the possibility of using it in external systems (outdoor substations, transformers, motors, etc.).

The sensors have a 90° opening angle that allows monitoring large areas and practically an entire cubicle with a single sensor, since it even detects UV reflected on the internal walls of the panel, thus detecting the start of arcs in areas not directly targeted.

The effective monitoring distances are high due to the high sensitivity of the sensors. Each arc sensor (up to 50 per Gateway in the case of the SPL variant) is connected to a high-speed CAN network connected to the triggering Gateway, which is responsible for providing the trip signal in less than 300 μ S.

The interconnection of the sensors to the detection and triggering gateway uses a high-speed CAN network with clean and efficient wiring, unlike star systems, with analog or non-analog signals, which require each sensor to be independently connected to concentrator or interface modules. The high speed of detecting the occurrence of an electric arc and sending the trip signal (300 μ s) ensures safety, because in the event of an electric arc, the sooner the energy is removed from the system, the less damage will be caused by the incident energy (up to 105 times less than systems with visible light).

Even if using circuit breakers with an opening time of tens of milliseconds, the system is guaranteed to trip even if the network interconnection cable were destroyed by the arc, since before the destruction the signal would have already reached the relay and the circuit breaker (in dozens of real protection cases that have occurred over many years of using Zyggot Arc systems, no Zyggot system was damaged, due to the high speed of operation, inhibiting the arc and not mitigating it). Another important difference is that the transmitted signals are digital, already processed in the microprocessor sensor and transmitted by shielded cables, and are therefore immune to extremely strong electromagnetic fields generated by the arc current, unlike what can occur with visible light detection systems, with photocell, which transmits analog signal to the interface.

BENEFITS

- * **Monitors ultraviolet radiation in bands A and B.**
- * **Detects phase 1 of the arc, before the visible light phase (i.e. expansion and destruction).**
- * **Dispenses with simultaneous current monitoring to determine the occurrence of an arc.**
- * **Sends the trip signal in less than 300 μ s.**
- * **A single Gateway with a state-of-the-art ARM CORTEX microprocessor monitors up to 50 arc sensors.**
- * **Reduction of incident energy by up to 150 times.**
- * **Low implementation cost.**
- * **High reliability.**
- * **Allows for high selectivity, if necessary (Multi Gateways).**
- * **“Open” system, does not depend on proprietary software, and can be interconnected to the DCS.**

PHASES OF THE ARC

Pre-Arc: Ionization of the air and formation of the path for the occurrence of an electric arc. In this phase, ultraviolet light is released (0 to 1 mS). This is the phase in which the arc sensor operates.

Compression: The energy of the arc is discharged into the air contained in the room, with a consequent increase in pressure (5 to 15 ms).

Expansion: The increase in pressure caused by the previous stage activates the relief mechanism and the air begins to be expelled to the outside, reducing the internal pressure (15 to 40 ms).

Expulsion: The pressure inside the room decreases, but the hot air continues to be expelled at an approximately constant pressure. The temperature potentially increases. The expulsion of air tends to be extinguished when the room's environment reaches the temperature of the arc (40 to 60 ms);

Thermal: The arc completely affects the insulating materials. The temperature reaches thousands of degrees Celsius and the conductive and structural materials begin to melt. This phase continues until the energy dissipates.

MAIN FEATURES OF THE SPL SYSTEM

- > Intelligent trigger gateway and relay (with ARM CORTEX microprocessors).
- > Applicable in low and medium voltage.
- > High-speed CAN network for sensors.
- > Gateway with Modbus RTU port for connection to PLCs and DCS.
- > Intelligent arc sensors powered by the CAN network itself.
- > 90° measurement angle.
- > Voltage and sensor status monitoring.
- > Does not require analog interfaces.
- > Gateway, Sensors and Relays can be configured and tested by PC with free software.
- > Allows high selectivity for tripping, using a low-cost trigger gateway per cubicle/circuit breaker.
- > Has Modbus communication and can be connected directly to the user's DCS system.
- > Up to 50 sensors connected to a single SPL Gateway. (Network with plug-in sensors).
- > Each sensor has an LED that flashes when commanded by the relay, to detect faults or their identification. > Gateway trigger with 3 digital outputs, one TRIP (solid state and mechanical) and two programmable and two programmable digital inputs.
- > Easy testing with ArcSafe manual tester (arc generator)

FASES DO ARCO



PRINCIPLE OF OPERATION OF THE ZYGGOT ARC SYSTEM MODEL ARC SPL

PRINCIPLE OF OPERATION

Each sensor in the system has a high-speed, high-performance ARM CORTEX microprocessor. The firmware embedded in the sensor will operate the communication and other tasks, but if an arc is detected, a high-priority interruption will occur and the arc detection data transmission routine, with the sensor number, will be immediately transmitted to the triggering Gateway. The time from the detection of the arc by the sensor until the activation of the Gateway's TRIP output is less than 300 μ s, activating a solid-state contact that supports 12 A continuously and up to 200 Amps peak for 5 cycles, plus a dry contact in parallel, allowing rapid actuation plus a guarantee of permanence through the mechanical contact.

The Modbus network connected to the Gateway allows, if desired, to acquire data from the Gateway, without the need for speed since the trip occurs through the Gateway. After detection, the Gateway memorizes the sequence of arc occurrence, or "Arc Chain", if more than one sensor is actuated or there is an arc chain coming from other Gateways. The high-speed CAN network of arc sensors connected to the Gateway provides high detection speed and the fact that the sensors detect the initial phase of the arc ensures that even if the network cable were destroyed by the arc itself, the trip sequence would be terminated, protecting the system from catastrophic destruction (Note: in hundreds of real cases reported by users, this has never happened. The system itself has never been destroyed, unlike light and current detection systems, which frequently suffer from this and there has also never been catastrophic destruction in real cases protected by UV).

The system will be protected even during the LED flash time or any other communication, since the CAN protocol has communication priorities, that is, more than one or even all network elements can generate communication at the same time and the one with the highest priority for all communication of lower priority packets is served immediately. Since the arc detection data packet is the highest priority, the arc detection signal will be read immediately by the intelligent Gateway. If one or more sensors detect arcing, a list of these sensors will be available to the user on the Gateway via Modbus communication. Each Gateway in the system can be configured using free software available on the Varixx website.

Gateway Trip Output

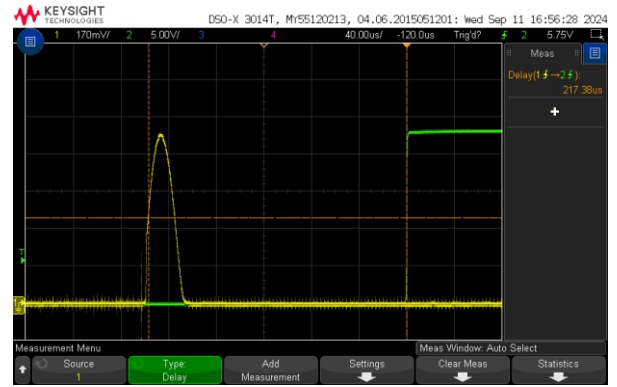

Ocorrência do arco Saída de trip

READING AND REFLECTION ANGLES

The sensor's opening (detection) angle defines the UV measurement area, i.e. the area where the arc can be detected. UVA and UVB sensors have an opening angle of 90°, covering practically the entire area of a cubicle, depending on the attachment point. In a single-compartment cubicle, a single sensor installed at a suitable point, such as in one of the corners, may be sufficient.

Two sensors at opposite angles leave the entire volume free of shadows. Ultraviolet radiation is reflected from surfaces like visible light (although it can be attenuated). Zyggot sensors can capture reflected UV radiation, which facilitates detection throughout the volume of interest.

SYSTEM RELATED TO THE SPL MODEL ARCH

- A) 90° arc sensor - ZSA/90/24/UVA/SPL
- B) 90° arc sensor - ZSA/90/24/UVB/SPL
- C) ZAG1R/SPL gateway
- F) Interconnection cable with mini-USB connector - ZCB/4/2U/...
- G) 24 VDC power supply VPS12024
- H) Tester (test arc generator) ZSA
- I) Termination resistor ZFR

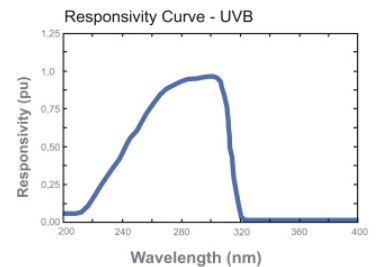
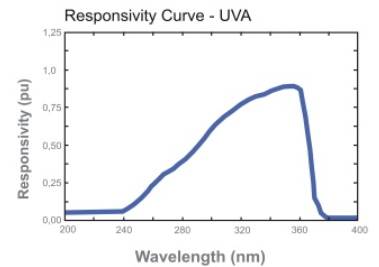
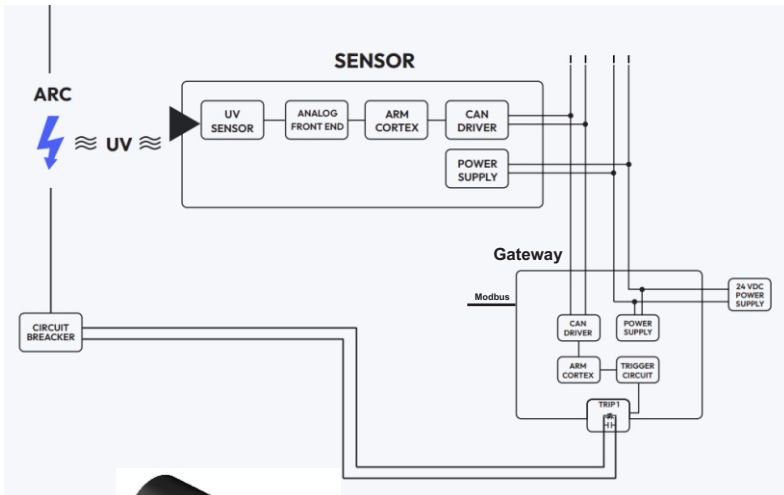

ZAG1R/L GATEWAY OVERLAY AND SIDE LABEL

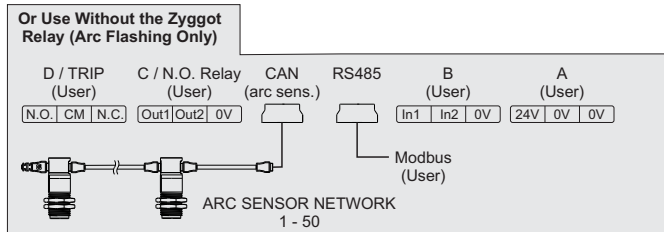
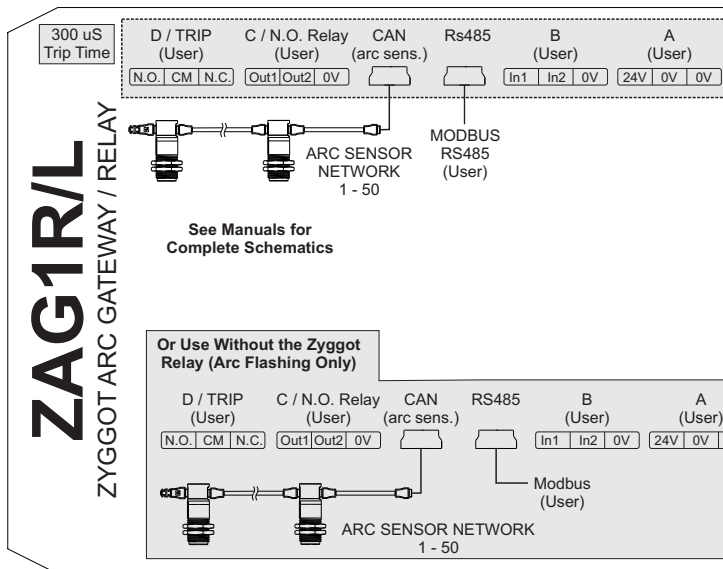
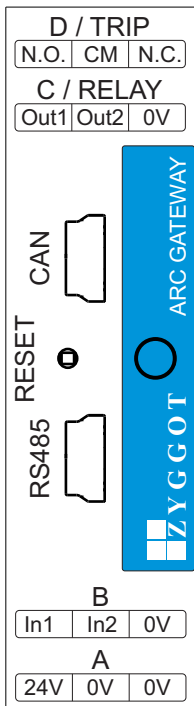

ZYGGOT THM / ARC SYSTEM
 Autonomous or Integrated Arc Flashing Relay
ZYGGOT
varixx

ZSA/90/24/UVA/SPL Sensor Features

- > Power supply: 24VDC via standard cable.
- > Opening angle: 90°.
- > LED indicator for location and faults.
- > Network addressing configurable via PC.
- > Detects UVA radiation and a small portion of visible light (240 to 340 nm).
- > Applicable in panels and sheltered environments.
- > Does not operate with ambient light or internal light from panels. (It may operate if pointed directly at UV light sources, such as clear sky, sun, flash or intense light).
- > Sensitivity to 2 cm electric arc produced by test device at a distance of 1 to 1.5 m or real arc at up to 30 m*
- * Depends on arc intensity (with 200A and 1 cm arc path the detection distance is 7 meters)

ZSA/90/24/UVB/SPL Sensor Features

- > Power supply: 24VDC via standard cable.
- > Opening angle: 90°.
- > LED indicator for location and faults.
- > Network addressing configurable via PC.
- > Detects UVB radiation (220 to 320 nm).
- > Applicable in panels, open environments or monitoring equipment outdoors.
- > Does not operate even with strong visible light (except if pointed directly at the sun, whose rays contain UVB).
- > Sensitivity to a 2 cm electric arc produced by a test device at a distance of 0.2 m to 0.4 m or a real arc of up to 10 m*.
- * Depends on the intensity of the arc (with 200A and a 1 cm arc path, the detection distance is 3 meters).



CABLES

The ease of assembling the sensor network lies in the two mini USB connectors present on the sensors and in the shielded mini USB cables supplied in different sizes by Varixx, ready to use.

PROGRAMMING TOOL

A PC program is provided free of charge by Varixx and allows parameterization and testing of the Gateway and sensors

GATEWAY COMMUNICATION PORT

The ZAG1R/L Gateway has 2 communication ports: One RS485 port with Modbus RTU protocol, for communication with supervisory systems or with Zyggot V5FTA relay or for connection to a PC for parameterization and one mini USB port with CAN protocol, for communication with networked sensors.

GATEWAY DIGITAL INPUTS

The Gateway has 2 digital inputs, 1 for Reset and 1 programmable by the relay or by the PC software. The "Reset" contact, if closed momentarily, performs the function of erasing the Gateway's alarms and trips, also erasing the Arc Flash occurrence sequence data.

DIGITAL GATEWAY OUTPUTS

The Gateway has 3 digital outputs, 1 for TRIP and 2 programmable by the relay or by the PC software. The trip output has an ultra-fast acting solid state relay and another N.A. dry contact in parallel. The programmable outputs are normally open dry contact type.

GATEWAY INDICATOR LED

The Gateway has 1 RGB LED, which will be «Green» if the gateway is programmed, configured and without alarms or trips. It will be «Yellow» in case of occurrence of alarms or trips that have not been reset or will be «Red» in case of a Trip that has not been reset.

NOTA: Uma condição de Alarme por "Sensor não respondendo" outro ocorrência não desativa a condição «Armado» e a conseqüente defecção em caso de ocorrência de arco. Por segurança o sistema, mesmo em alarme estará ativo para detecção de Arc Flash.

CONECTOR MINI USB MULTI-FUNÇÃO DO SENSOR

Os conectores mini-USB no sensor servem tanto para parametrização, utilizando um cabo padrão mini USB / USB (fornecido separadamente) e um PC, quanto para comunicação com o Gateway através do cabo da rede (fornecido separadamente). As portas mini USB do sensor estão em paralelo não havendo diferença entre qual porta conectar o cabo. A dupla porta mini-USB facilita a montagem da rede. Para detalhes de como parametrizar o sensor consulte a seção de programação.

CAUTION

Não conectar o sensor ao computador com a outra extremidade do sensor conectada à rede de sensores. Isto pode danificar o sensor e o computador!
Para parametrização deve-se ligar um sensor por vez ao computador.



SYSTEM DETAILS RELATING TO ZYGOT ARCO SPL SYSTEM

CABLE LENGTH SELECTION OF EACH SENSOR AND THE NEXT

The sensors are connected to the network using a shielded sleeve-type cable, without the need for any tools. These cables, which already have a mini USB connector on both ends, are supplied by Varixx in various lengths.

Below are the available codes and sizes.

ZCB/4/2U/030	Cabo de conexão dos sensores 0,3 m
ZCB/4/2U/050	Cabo de conexão dos sensores 0,5 m
ZCB/4/2U/100	Cabo de conexão dos sensores 1 m
ZCB/4/2U/200	Cabo de conexão dos sensores 2 m
ZCB/4/2U/400	Cabo de conexão dos sensores 4 m
ZCB/4/2U/600	Cabo de conexão dos sensores 6 m
ZCB/4/2U/800	Cabo de conexão dos sensores 8 m

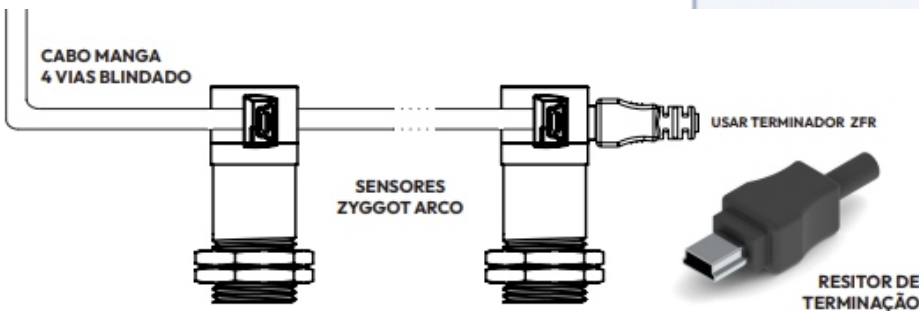

TRANSIENT SUPPRESSOR IN THE GATEWAY TRIP CONNECTION

It is mandatory to use a type of transient suppressor compatible with the type of load. For trip coils (highly inductive), it is recommended to use a Varistor with appropriate characteristics. Possible variations for this circuit are "Free Wheeling Diode" (for DC power) and "Snubber" circuit composed of Resistor and Capacitor. This minimizes the generation of arcs in the 52a contact of CB1 and noise, increasing the useful life of the system and avoiding interference and improper operation of other equipment. If in doubt between the types of circuit, use the varistor. Consult the Circuit Breaker Manual.

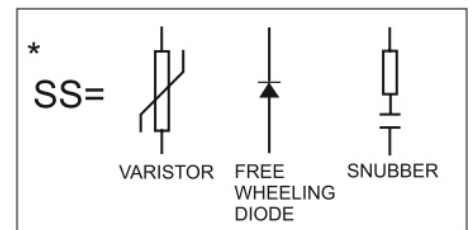

ZYGOT SPECIFICATIONS

Arcing Sensors	(No Contact)
Tightening	2 x Nuts
Power Supply Types	By CAN Network
UV Wavelength	200 to 320 nm
Case Type	Stainless Steel
Sensor Measurement Angle	90°
Radiation Rages	UVA and UVB Insensible to visible and IR
Sensor Transmission Type	High Speed CAN
Temperature Operation	-20 to 89 °C
Temperature Storage	-40 to 125 °C
Maximum Measurement Range (distance from sensor to target)	30 m depending on the Arc Power
Max. CAN Cable Length	500 m
Configuration (Address, Sensitivity)	By Computer with Free Program
Indication	Led at rear face
Max. Sensors per Gtwy SPL	50
CE	Compliant

EXAMPLE OF TYPICAL APPLICATION WITH 115 VAC / 125 VDC TRIP COIL

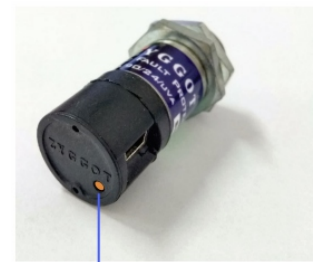
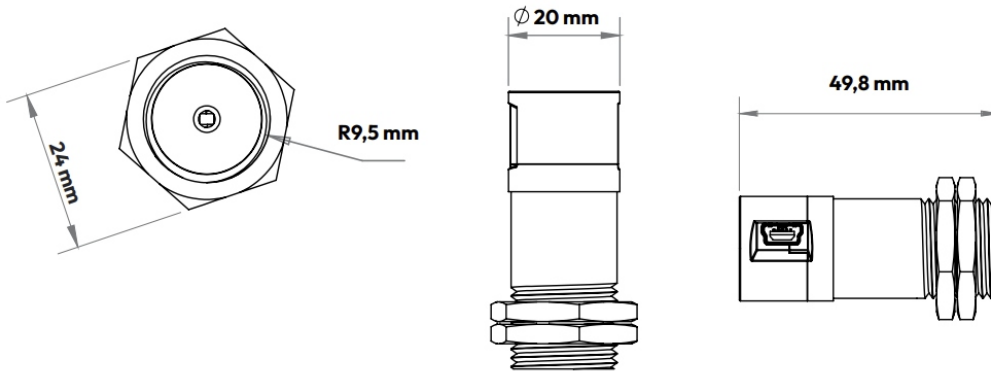
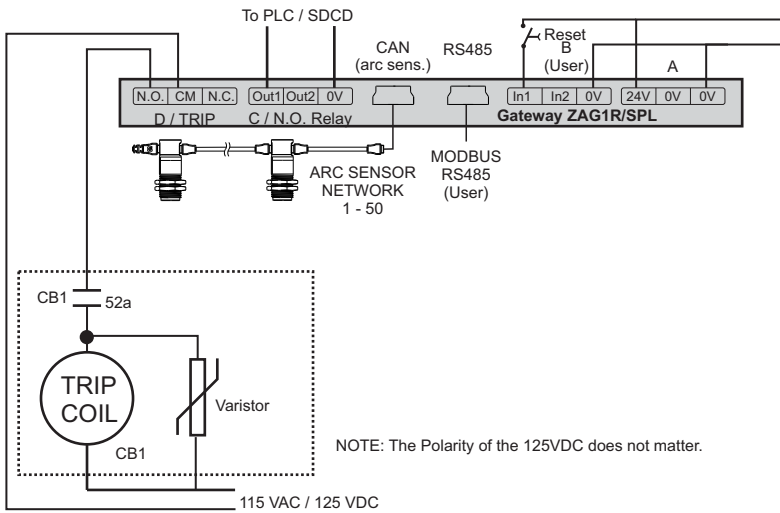

YELLOW LED

PROGRAMMING THE SENSORS

- 1 - Download and install the free software "ZyggotArc Configurator" from the Varixx website (<http://www.varixx.com.br>).
- 2 - Open the configuration program.
- 3 - Connect the sensor to the computer's USB port using a mini USB / USB cable (connect one sensor at a time). When the sensor is connected, its back light will turn on. The program automatically detects the sensor. If this does not happen, you can choose manual connection, choose the serial port corresponding to the USB to which the sensor cable is connected and press the Connect key to attempt a connection. When connecting (in both manual and automatic mode), a green light will turn on in the program indicating that the connection was successful.
- 4 - Program the sensor address (from 1 to 50 in the case of the SPL version) in the corresponding window and press «Send» to save the information to the sensor. Disconnect the sensor by simply removing it from the cable.
- 5 - It is advisable to label the sensor with its programmed address to make it easier to assemble in the field. If you wish to configure another sensor, return to step 3. Then check that there are no duplicate addresses between the sensors.
- 6 - Once all the sensors have been programmed with the addresses, fix the sensors in the defined positions using the two nuts on the front of the sensor. As a suggested assembly, we recommend using our metal "adjustable fixing bracket" (REF. ZSF2), with adjustable angle, which allows the use of just one Boelhoff rivet or similar in the chosen location, to fix the sensor and direct it.

IDENTIFICATION OF ARC SENSORS

When the sensors are powered on, each sensor will flash its rear LED indefinitely until the first communication with the relay occurs. This allows for a quick check of communication with the relay and sensor integrity. If in doubt, disconnect the sensor and then reconnect it. The LED should flash for a very short time and then remain on continuously.

If it continues to flash, it is because it is not communicating. Check the cables, programming the sensor address and programming the number of sensors in the relay. Obviously, if the sensor is not communicating, the relay will also indicate the lack of communication.

TYPICAL APPLICATION EXAMPLE USING ONE OR MORE SPL GATEWAYS

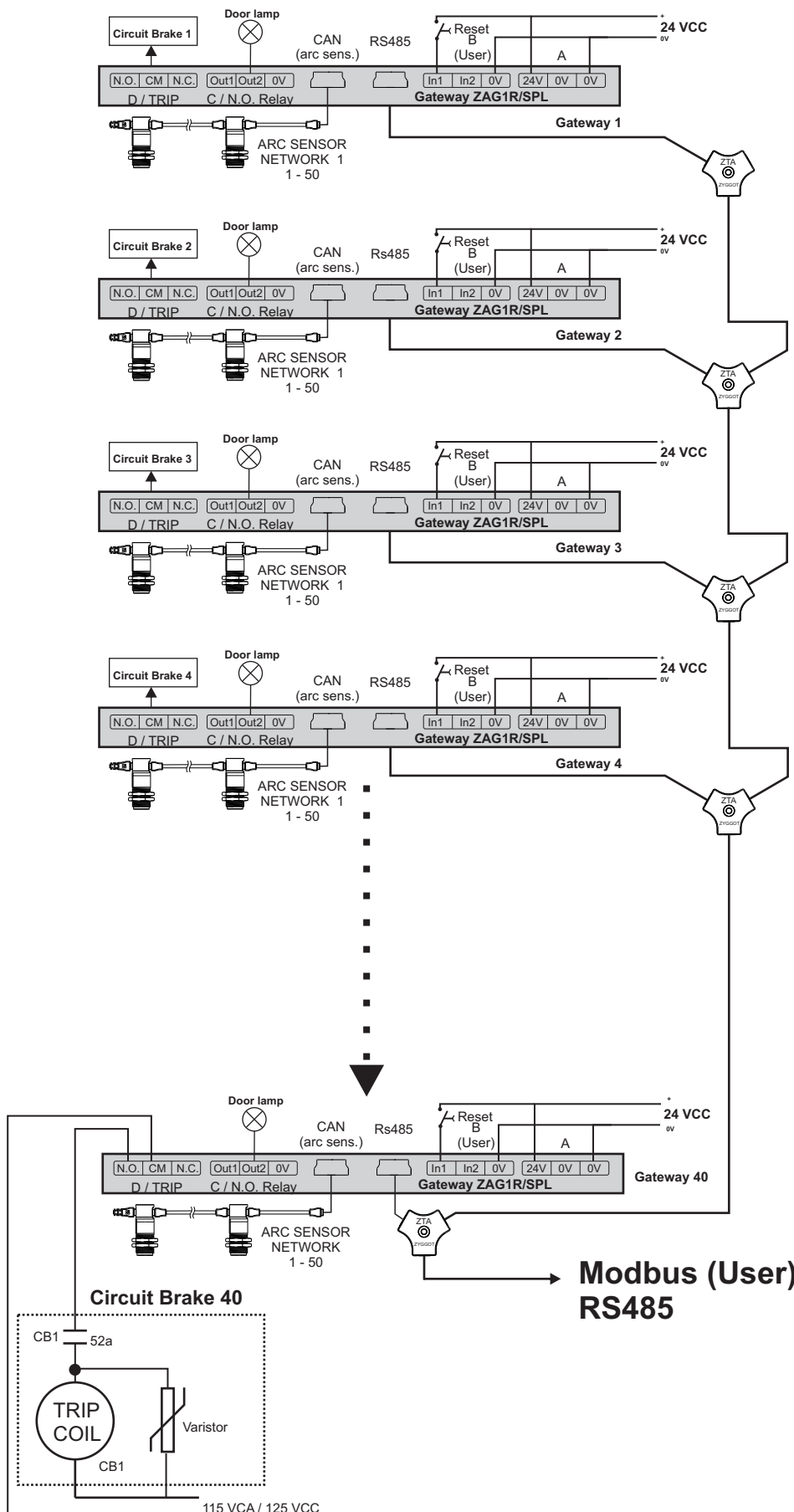

In cases where high selectivity is required, such as in cases of distribution branches with one circuit breaker per branch, the side topology can be used with multiple triggering Gateways, each one triggering its own associated circuit breaker, each one with up to 50 arc sensors, i.e. configuring a low-cost, high-efficiency system (Multi Gateways). Each Gateway sends the «TRIP» signal to its circuit breaker in less than 300 µs.

Note that it is possible to use only one Gateway with its sensors, which can be from 1 to 50. Typically, one Gateway per cubicle, associated with its circuit breaker, and 1 or two Zyggot UV Arc sensors would be enough to have each cubicle fully protected against Arc-voltaic.

NOTE: The Polarity of the 125VDC does not matter.

PROGRAMMING SENSORS WITH ZYGGOT SUPERGER SOFTWARE

PROGRAMMING - ZYGGOT ARCO SENSORS

Zyggot Superger is a configuration software that addresses and tests sensors, as well as parameterizes and configures Zyggot relays for versions other than SPL. The software is available for free download from the Varixx website (<http://www.varixx.com.br>). The figure below shows the home screen of the Zyggot Superger software.

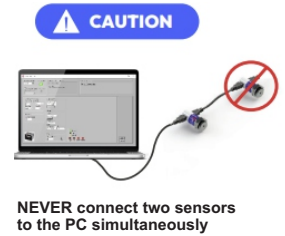

The software automatically recognizes the device and the port to which it is connected to the computer. If the port is not recognized, you can manually select the port using the Manual Connection box. When choosing to connect manually, you must select the serial port to which the device is connected and press the Connect button. When a sensor is connected to the computer, the program screen automatically changes to the image below. When connecting a sensor, the program automatically reads the address settings.

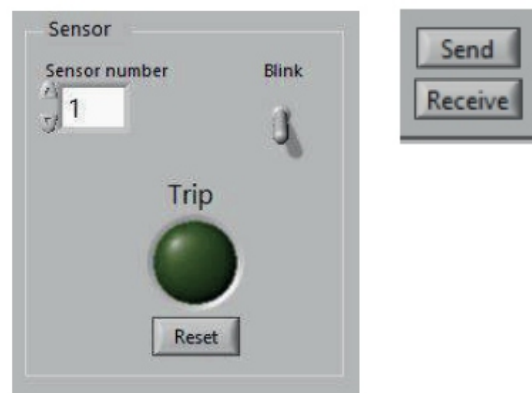
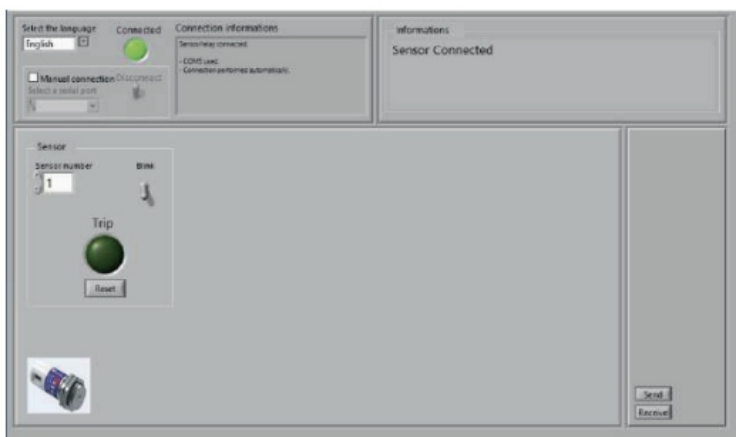

To set a new address for the sensor, you must change the sensor number in the Sensor tab. When you do this, the sensor number will flash red, indicating that the change has not yet been sent to the sensor. To save the change, press the Send button. The Sensor tab also provides the sensor's Trip indicator. If you want to test the sensor, use the ArcSafe tester to generate an arc in front of the sensor. When an arc is detected, the Trip indicator will change to red, and the LED on the back of the sensor will flash for a few moments. To restore the sensor status, press the Reset button. Use the Blink key to make the LED on the back of the sensor flash indefinitely. Press again to stop. When you want to disconnect the sensor, simply remove it from the mini USB port.

ZYGGOT ARC SPL SYSTEM COMPOSITION

COD: ZSA/90/24/UVA/SPL



UVA AR SENSOR

Technical information

FEATURES: ARC UVA SENSOR

Measuring angle:	90°
Power Supply:	24 VCC by the NET
Detection range:	UVA (240 to 380 nm)
Test sensitivity:	1 to 1,5 m (w/tester ZSA)
Real Arc Sensitivity:	up to 30 m
LED status indicator:	Included
Settings:	By PC software
Diameter:	19mm
Length:	53mm
Communication:	Rede CAN 512 MBs
Material:	Stainless Steel and Polycarbonate

COD: ZSA/90/24/UVB/SPL



UVB ARC SENSOR

Technical information

FEATURES: ARC UVB SENSOR

Measuring angle:	90°
Power Supply:	24 VCC by the NET
Detection range:	UVB (220 to 320 nm)
Test sensitivity:	1 to 1,5 m (w/tester ZSA)
Real Arc Sensitivity:	up to 30 m
LED status indicator:	Included
Settings:	By PC software
Diameter:	19mm
Length:	53mm
Communication:	Rede CAN 512 MBs
Material:	Stainless Steel and Polycarbonate

COD: ZAG1R/SPL



GATEWAY FOR SPL ARCH SYSTEM

ACCESSORIES

Accessory

COD: VPS6024 ou VPS12024



POWER SUPPLY

Accessory

COD: ZSF2



Support for fixing and sight for tubular

Accessory

COD: VZX/B1/U ou VZX/B1/U/P



SUITCASE WITH LASER SIGHT

Accessory

COD: ZFR

COD: ZTA

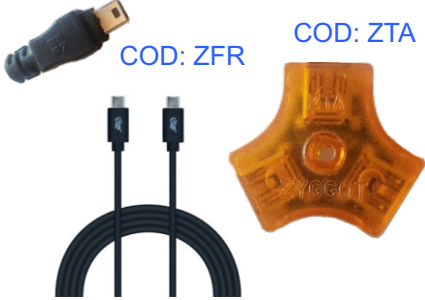

COD: ZCB4/2U/xxx

Y-split Derivator, USB cables and terminating resistor

Accessory

COD: VLP2



Laser sight attachable to tubular sensor for startup

Accessory

COD: RJ45/C2
(Comes with each V5CON module and each Eblock)



RJ45 CABLE

Accessory

COD: ZSA



ARCSAFE Arc Tester

GENERAL SPECIFICATIONS

Input Register (Modbus function 04) (read-only)																
WORD = 16 BIT											0 a 100 sensores					
OFFSET	32768	16384	8192	4096	2048	1024	512	256	128							
	16	15	14	13	12	11	10	9	8	7	6	5	4	3	2	1
1	Version (value 100 = 1.00)															
2	Serial Number 32bits - LSB															
3	Serial Number 32bits - MSB															
4	Manufacture Day															
5	Manufacture Month															
6	Manufacture Year															
7	Manufacture Lot															
8	Manufacture User 1															
9	Manufacture User 2															
10	Manufacture User 3															
11	Manufacture User 4															
12	Sensor Number (Last Sensor Of Network)															
13	Trip List Size															
100	OUT TRIP	OUT_2	OUT_1	IN_2	IN_1	Any Sensor Not Respomding	Any Sensor Configured	Any Sensor Trip	CHAIN 0= None , 1= Chain	Trip Sequence Size (0=none)						
101	OUT TRIP	OUT_2	OUT_1	IN_2	IN_1	Sensor 1 Not Responding	Sensor 1 Configured	Sensor 1 Trip		Sensor 1 Trip Sequence (0=No 1=First N=Position)						
102	TRIP	OUT_2	OUT_1	IN_2	IN_1	Sensor 2 Not Responding	Sensor 2 Configured	Sensor 2 Trip		Sensor 2 Trip Sequence (0=No 1=First N=Position)						
150	TRIP	OUT_2	OUT_1	IN_2	IN_1	Sensor 50 Not Responding	Sensor 50 Configured	Sensor 50 Trip		Sensor 50 Trip Sequence (0=No 1=First N=Position)						
201	Trip List 1 (0=None N=Sensor)															
202	Trip List 2 (0=None N=Sensor)															
249	Trip List 49 (0=None N=Sensor)															
250	Trip List 50 (0=None N=Sensor)															
301	Sensor 1 Version (100=1.00)															
302	Sensor 2 Version (100=1.00)															
349	Sensor 49 Version (100=1.00)															
350	Sensor 50 Version (100=1.00)															
401	Sensor 1 Level															
402	Sensor 2 Level															
450	Sensor 50 Level															
1010	0															
1011	Event 1 - Sequence ID															
1012	Event 1 - Sensor Number															
1013	Event 1 - Timestamp Day															
1014	Event 1 - Timestamp Month															
1015	Event 1 - Timestamp Year															
1016	Event 1 - Timestamp Hour															
1017	Event 1 - Timestamp Minute															
1018	Event 1 - Timestamp Seconds															
1019	Event 1 - Repeat Count															
1500	0															
1501	Event 50 - Sequence ID															
1502	Event 50 - Sensor Number															
1503	Event 50 - Timestamp Day															

FACTORY DEFAULT SETTING

The Gateway leaves the factory ready for use with the following settings. Simply configure the PLC in a compatible way to operate. If using only one Gateway, use the factory default address 200 to make things easier. If using multiple Gateways, program the address of each one in sequence, for example 201, 202, 203, etc.

GATEWAY GAZ1R/SPL	
ADDRES:	200
BAUDRATE:	19200
PARITY:	NONE
DATA BITS:	8
STOP BITS:	1
HANDSHAKE:	MD HALF
PROTOCOL:	MODBUS RTU
PORT MODE:	RS485

GENERAL SPECIFICATIONS

Offset	16	15	14	13	12	11	10	9	8	7	6	5	4	3	2	1	Default Hex
Holding Register (Modbus function 03) (read-write)																	
WORD = 16 BIT																	
1	Trip Mode 0 → Keep On 1 → Pulse 3 Sec	OUT_2 Mode B2 B2=0 B1=0 → Trip B2=0 B1=1 → Armed (No Trip) B2=1 B1=0 → Alarm B2=1 B1=1 → Remote 2	OUT_2 Mode B1	OUT_1 Mode B2 B2=0 B1=0 → Trip B2=0 B1=1 → Armed (No Trip) B2=1 B1=0 → Alarm B2=1 B1=1 → Remote 1	OUT_1 Mode B1	IN_2 Mode B2 B2=0 B1=0 → None B2=0 B1=1 → Reset B2=1 B1=0 → Inhibits/Disable Trip B2=1 B1=1 → Chain	IN_2 Mode B1	IN_1 Mode 0 → None 1 → Reset	Sensor Network Size (0...100) (Last Sensor Of Network)								0x0000
2	x	x	x	x	x	x	x	Blink Active 0=no / 1=Blink	Sensor to Blink (0=All) BIT 1 - 8 = 0 a 100 sensors								0x0000
3	Unlock Bits 12 to 15 0=no / 1= Unlock	Force Out Trip SCR 0=no / 1= force	Force Out Trip Relay 0=no / 1= force	Force OUT_2 0=no / 1= force	Force OUT_1 0=no / 1= force	Remote_2 0= Off / 1= On	Remote_1 0= Off / 1= On	x	x	x	x	x	x	x	x	Reset Trip 0=no / 1=Reset	
4	Unlock 0 → Read-only 1 → Enable Bits 1 to 14	Terminator RS485 0 → No Resistor 1 → 120R Resistor	Baudrate Mode B3 B3=0 B2=0 B1=0 → 1200 B3=0 B2=0 B1=1 → 2400 B3=0 B2=1 B1=0 → 4800 B3=0 B2=1 B1=1 → 9600 B3=1 B2=0 B1=0 → 19200 B3=1 B2=0 B1=1 → 38400 B3=1 B2=1 B1=0 → 57600 B3=1 B2=1 B1=1 → 115200	Baudrate Mode B2	Baudrate Mode B1	Parity Mode B2 B2=0 B1=0 → None B2=0 B1=1 → Even B2=1 B1=0 → Odd	Parity Mode B1	Stop Bit Mode 0 → 1 stop bits 1 → 2 stop bits	RS485 Gateway Modbus Address - SLAVE ID (Initial = 200)								0x20C8
5	Sensor Network Size (0...100) (Last Sensor Of Network)																
6	IN_1 Mode (0=None, 1=Reset)																
7	IN_2 Mode (0=None, 1=Reset, 2=Inhibits/Disable OUT_TRIP, 3=Chain)																
8	OUT_1 Mode (0=None, 1=Armed (No Trip and Configured), 2=Alarm, 3=REMOTE_1)																
9	OUT_2 Mode (0=None, 1=Armed (No Trip and Configured), 2=Alarm, 3=REMOTE_2)																
10	OUT_TRIP (0= Keep On, 1= Pulse 3 Sec)																
11	Sensor to Blink (0=All)																
12	Blink Command (0=Blink_Off, 1=Blink_On, 2=None)																
13	Clock Control (0=Keep, 1=Rear, 2=Write)																
14	Clock Day (1..31)																
15	Clock Month (1..12)																
16	Clock Year (1..3000)																
17	Clock Hour (0..24)																
18	Clock Minute (0..60)																
19	Clock Second (0..60)																
20	Clear All Saved Event																
21	Start Loader Password																

ABOUT VARIXX

For over 40 years, Varixx has pursued its vocation for developing high-tech products and focuses its efforts on serving the industrial market with quality and speed. Our know-how in power electronics has allowed us to offer the market a wide range of products that have become known for their long service life and reliability. We were the creators of the global online thermography market, with the Zyggot line, which is becoming a global reference in the market for temperature monitoring and diagnostics and arc flash detection in electrical systems in general.

Our product portfolio also includes LED luminaires from our ONNO division, developed and manufactured 100% in Brazil with cutting-edge technology. Varixx values the introduction of innovative concepts worldwide.

AREAS OF ACTIVITY

- ✓ **MANUFACTURERS OF GENERATOR MACHINES AND SYNCHRONOUS MOTORS**
Static Exciters, Control Box Controllers, Low and Medium Voltage Soft Starters, Semiconductors
- ✓ **PRODUCTION OF ALUMINUM AND HYDROGEN / OXYGEN**
High Current Rectifiers, Solid State Contactors, Smart Relay for CCM, Online Thermography System and Arc Flash Detection and Onno LED Luminaires.
- ✓ **BASE INDUSTRY, MINING AND STEEL INDUSTRY**
Smart Relays for CCMs, Low and Medium Voltage Soft Starters, Solid State Contactors, AC/DC Converters for electromagnets, High Current Rectifiers, Online Thermography System, Arc Flash Detection and Protection and Onno LED Luminaires.
- ✓ **OIL COMPANIES**
Smart Relays for CCMs, Static Excitation, Low and Medium Voltage Soft Starters, Solid State Contactors, Online Thermography System, Arc Flash Detection and Protection and Onno LED Luminaires.
- ✓ **ELECTRIC PANEL ASSEMBLERS**
Smart Relays for CCMs, Online Thermography, Arc Flash Detection and Protection System, Semiconductors, Power Supplies and Onno LED Luminaires.

Why ZYGGOT Thermography And Arc Flash Protection?



SINGLE CABLE / EASY TO INSTALL



PREDICTIVE / DIFFERENTIAL PROTECTION



EFFECTIVE PROTECTION AGAINST ARC DESTRUCTION



WORLDWIDE UNIQUE BY UV DETECTION / NO CURRENT READING REQUIRED



DOES NOT NEED CONVENTIONAL THERMOGRAPHY / ALSO MEASURES AIR TEMP.



WITHOUT CONTACT / WITH NETWORK COMMUNICATION

LEARN MORE!

ZYGGOT ARC FLASH SYSTEM

- ✓ **Low Cost // Up to 100 sensors per relay.**
- ✓ **Innovative in the market // Faster (<300 uS versus up to 500 mS)**
- ✓ **Ultraviolet arc detection**
- ✓ **Does not operate with ambient light (False Alarm)**
- ✓ **No need current reading**

varixx

ALWAYS INNOVATING

www.varixx.com.br
vendas@varixx.com.br
+55 (19) 3424-4000
+55 (19) 3301-6900

R. Felipe Zaidan Maluf, 450
Distrito Industrial Unileste
Piracicaba-SP. CEP: 13422-190



@Varixxbrasil



@varixxcompany



Varixx Indústria Eletrônica



www.varixx.com.br

Representative/Distributor:

VARIXX USA

2229 Allen Parkway, Suite 200
+1 832-871-5700
Houston - Texas, 77019

VARIXX WORLDWIDE

MORE THAN 20 BRANCHES,
DISTRIBUTORS AND REPRESENTATIVE
OFFICES WORLDWIDE



ZYGGOT THERMOGRAPHY