



ZYGGOT THERMOGRAPHY + OZONE + HUMIDITY

Complete Predictive System for Arc Flash Prevention with Ultra Sensitive 0 to 2000 ppb Ozone Monitoring

ONLINE TEMPERATURE + PARTIAL DISCHARGE/CORONA + HUMIDITY MONITORING



MANUAL

World's First Online Thermography System (2004).
 World Leader in Continuous Temperature Monitoring.
 World's First UV Arc Protection System.*
 Over 1 Million Sensors Installed Worldwide.
 * Patent N° PI 0903809-4

MANUAL ZYGGOT V5F/TOH V17 - Build 41 - ENG - May 2025

varixx

INDEX

HISTORY / FUNCTION / BENEFITS / SYSTEM	3
ADVANTAGES / KEY POINTS / APPLICATIONS / FEATURES	4
BENEFITS OF TEMPERATURE MEASUREMENT + OZONE + HUMIDITY	5
TECHNOLOGY AND TECHNICAL DETAILS	6
MEASUREMENT AREA, EMISSIVITY, MEASUREMENT ANGLES	7
CAPTURE OF TEMPERATURE MEASUREMENT AND INFLUENCE OF EMISSIVITY	8
TEMPERATURE MEASUREMENT CAPTURE AND ACCESSORIES	9
PROTECTION AND EMISSIVITY COMPENSATION WITH UNIDEX TAPE	10
SYSTEM DETAILS RELATED TO SENSORS	11
SENSOR PROGRAMMING	12
COMPOSITION OF THE SYSTEM T+ A + O + H.....	13
ACCESSORIES	14
V5CON AND EBLOCK INTERFACE DETAILS	15
SINGLE-LINE DIAGRAM USING EBLOCK AND MAIN FEATURES	16
TYPICAL CONNECTIONS	17
MECHANICS	21
TECHNICAL CHARACTERISTICS	22
V5F/TOH RELAY - TECHNICAL SPECIFICATIONS	23
MAIN SCREENS FOR OPERATION	24
PROGRAMMING MENU	44
TESTING THE ETHERNET CONNECTION	65
OPERATION	66
SCREEN FLOW - OPERATION	68
SCREEN FLOW - PROGRAMMING	76
COMPUTER PARAMETERIZATION - ZYGGOT SUPERGER	78
SENSOR CONFIGURATION	82
FAIL SAFE SYSTEM	84
HOW TO DO IT	85
SUPERVISORY SOFTWARE	87
ASCII DATA TABLE OVER TCP/IP	90
MODBUS	91
ZYGGOT RELAY V5F/TOH MODBUS MAP	101
THM SENSORS NETWORK MODBUS SPEC	105
OZONE SENSORS NETWORK MODBUS SPEC	106
MODBUS OVER ETHERNET TCP IP SERVER	107
ETHERNET MODULE IN STUDIO 5000/LOGIX DESIGNER ALLEN BRADLEY	111
BT SENSOR TEST REPORT	116
ABOUT VARIXX	118

Note: This manual is written in ENGLISH and the same manual is also available on the website Varixx.com and Varixx.com.br in PORTUGUESE (PT-BR). The Zyggot relay leaves the factory with 3 selectable languages, English, Portuguese and Spanish, and can also be supplied with other languages, upon request.

ZYGGOT THERMOGRAPHY

TEMPERATURE +OZONE+HUMIDITY PROTECTION SYSTEM



DESCRIPTION

Varixx was the world's first company to introduce a Continuous, Online, Networked Temperature Monitoring System in 2008 and is a market leader in this area. The low-cost ZYGGOT system was designed to allow online monitoring of the temperatures of low and medium voltage components and internal connections, transformers, motors, etc., replacing old methods of periodic thermography with cameras.

The ZYGGOT system introduced an important innovation to the market because current safety standards prohibit the opening of energized electrical panels for any type of measurement, including temperature measurements with manual point-of-care guns or thermography cameras, without the use of appropriate protective clothing.

An important feature of the ZYGGOT system is that it simultaneously measures both the **target and the sensor body**, which is equal to the temperature of the surrounding air.

This feature also allows the detection of an increase in the internal temperature of the panel, which can identify obstructions or ventilation failures or even an increase in the temperature of equipment not directly monitored.

Sensors with opening angles of 7° allow the monitoring of both well-defined points (points) and areas of any size, depending on the distance from the sensor to the area.

Varixx also introduced the world's first and only Ultraviolet arc detection system in 2014, which does not require confirmation of current rise and inhibits arc formation at its onset due to its extremely fast action (<250 uS), detecting the arc in its initial phase and not in the fourth phase of the arc, already formed, thereby reducing the Incident Energy by around 80 to 150 times compared to the competition. It is a system that has already been widely approved, with hundreds of real cases of detection and action, with minimal or no damage to the protected systems, with a return to operation time of minutes to a few hours.

Furthermore, as it does not require current monitoring, it is very easy to implement and costs much less than light and current detection systems.

In addition to the systems mentioned above, Varixx has introduced the integrated Continuous Temperature Monitoring + Arc Flash Protection systems - V5FTA/O and V5FTA/M respectively Mono and Multi Gateway and also the integrated Continuous Temperature Monitoring + Ozone + Humidity system - V5F/TOH, the equipment covered in this manual, establishing a complete predictive system against possible future electric arcs in the monitored equipment, since the 3 main variables that can lead to the occurrence of an arc are covered and the readings can be obtained worldwide since the relay has Modbus and Ethernet communication.



Gateway

Sensor THM



Sensor BT



Sensor OZÔNIO



FUNCTION

Monitoring, Alarm and Trip based on the 4 most important variables for preventing Arc Flashes (250 independent measurements):

- * Multi connections temperatures
- * Multi internal air temperatures of the panel
- * Multi Ultra-sensitive ozone level
- * Multi Air humidity inside the panel

BENEFITS

- * Prevents opening of the energized panel.
- * Dispenses with periodic thermography.
- * Readings of up to 125 target temperatures (points) and 125 internal air temperatures.
- * Readings of up to 125 ozone level sensors with extremely high sensitivity in the order of parts per billion + 125 internal air humidity levels.
- * Non-contact measurement.
- * May trigger an alarm in the event of an increase in temperature or ozone levels over time.
- * Indicates a faulty sensor.
- * Failure history.
- * Modbus and Ethernet communication

System

- * Applicable in low, medium and high voltage.
- * Up to 125 non-contact temperature sensors (250 point and air readings), and 125 ozone and humidity sensors (up to 250 readings) in RS485 network with mini USB connections.
- * Smart sensors powered by the network itself.
- * 7° measurement angle for temperature.
- * Continuous temperature, ozone and humidity level readings.
- * Relay with color graphic Touch Screen display with Modbus and Ethernet communication.
- * Fault history with "Time Stamp".
- * Readings and protections related to 4 analog inputs.
- * External fault monitoring.
- * Sensor status monitoring.
- * 4 programmable digital outputs.
- * Each sensor has a flashing LED and can be controlled by the relay to facilitate its location and address in the network.
- * Operation in «Fail Safe» mode
- * Ethernet protocols:
 - TCP/IP (Modbus Slave):** Modbus over Ethernet).
 - Ethernet/IP:** ODVA CIP over Ethernet.
 - FTP:** (File Server) File Transfer Protocol.
 - ASCII over TCP/IP:** ASCII Data over Ethernet.
 - NTP Protocol:** Network Time Protocol
 - HTTP (Web Server):** Hypertext Transfer Protocol (Web Server).

KEY POINTS

MAIN ADVANTAGES

CAN BE TESTED WITH THE SYSTEM OFF

WITH ETHERNET

4 IMPORTANT MEASUREMENTS (PREDICTIVE)

MEASURES OZONE IN PARTS PER BILLION

HIGHLY PREDICTIVE FOR PARTIAL DISCHARGES

DIFFERENTIAL ALARM ACTUATION

AVOID CONVENTIONAL THERMOGRAPHY

MEASUREMENT WITHOUT ELECTRICAL CONTACT

TOUCH SCREEN FRIENDLY COLOR SCREENS

DOES NOT USE BATTERIES

INDIRECTLY MEASURES THE ENTIRE SYSTEM (AIR)

PROVEN RELIABILITY

HISTORY OF EVENTS

INCLUDES DATA PLOTTING

WORLD LEADING SYSTEM

KEY POINTS

- Color Touch Screen.
- Has Ethernet communication with several protocols.
- Measurement of up to 125 different points of ultra-sensitive ozone from 0 to 2000 parts per billion (ppb) for detection of Corona / Partial Discharges.
- Measurement of up to 125 different points of relative humidity levels of the air inside the panel.
- Measurement of the 4 most important causes for generation of Electric Arc.
- Ultra predictive, with built-in programmable differential variation calculation.
- Several built-in protections.
- Graphical recording in real time (Plot).
- History of failures and events.
- Continuous readings of target and sensor's surrounding air temperatures.
- Modbus RTU communication (and others).
- Networks of common temperature and arc sensors.
- Each relay presents up to 375 continuous measurements namely: Temperature of up to 125 targets, Temperature of up to 125 sensor bodies (surrounding air), Ozone level of up to 125 different points, Relative humidity level of up to 125 different points and voltage of up to 125 temperature sensors and voltage of up to 125 ozone + humidity sensors (allowing monitoring of network integrity).

APPLICATIONS

- Internal panels for online thermography of connections + air temperature + detection of partial discharges / corona by ozone levels + measurement of relative humidity.
- Fully predictive protection for the 4 most important causes of electric arcs.

MAIN FEATURES

- Modbus RTU + Ethernet
- Reads temperature of up to 125 targets per relay. Reads temperature from up to 125 sensors (body/surrounding air), allowing detection of temperature increases at points not directly monitored.
- Reads ozone levels from up to 125 sensors
- Reads relative humidity from up to 125 sensors.
- Reads supply voltage from up to 125 sensors.
- Up to 125 Temperature or Ozone+Humidity sensors per relay.
- Monitors partial discharge/corona by ultra-sensitive ozone detection.
- Configurable alarm and trip levels for target temperatures, surrounding air, ozone and humidity for each of the 125 sensors.
- Real-time graphical recording for temperatures and ozone.
- Detection of differential temperature increases integrated into the relay and configurable by the user.
- Failure and status history.
- Continuous readings.
- 4 analog inputs with configurable alarm and trip levels.
- 4+8 digital inputs for external events or faults (ventilation, doors, etc.).
- 4+8 digital outputs for signaling, alarm and trip.
- Color Touch Screen Display providing user-friendly programming and operation.
- Event memorization (history) with Real Time Clock.
- Data recording on included memory card.
- Plot of readings in graphs on the screens and recording on included memory card.
- Internal intelligence, programmable for alarm and trip by differential variation as a function of time.
- Easy installation and commissioning without the need for tools. All connections are Plug and Play.

The ZYGGOT system with stainless steel tubular sensors was developed for low, medium and medium voltage panels, measuring both connection points without electrical contact and air temperature in each sensor + ultra-sensitive ozone sensors, with detection in the order of parts per billion, in addition to measuring relative humidity. THM sensors measure temperature, without physical contact, by infrared detection and allow local and online reading and protection for up to 125 targets per relay. Each sensor measures two temperature levels: of the target and of the air surrounding the sensor (case), allowing fault detection at unmeasured points, by indirect heating of the air. They are networked, using mini USB cables, in sizes from 0.3 to 8.0 meters (supplied), which allows for quick, error-free and tool-free installation.

Ozone and Humidity Sensors are ultra-sensitive, measuring from 0 to 2000 Parts per Billion of ozone in the air. Systems with compromised or aged insulation present a high rate of Partial Discharges which generate ozone (O³) production. An increase in Ozone levels over time indicates the need for predictive maintenance before the eventual occurrence of an electric arc. These sensors also measure the relative humidity of the air inside the panel, which is also

an important variable for the generation of an electric arc.

The relay provides local protection and also through a supervisory system. Alarm and trip levels are freely programmable for each point and each variable. A possible failure in one of the sensors does not interrupt the operation of the other sensors. In addition to the tubular sensors mentioned, which are applied in medium and high voltage systems, LV sensors can also be used in low voltage MCCs, which require a large number of sensors in a small space, in addition to demanding a low cost. Its quick-fix base can be fixed by means of a screw or by means of a stainless steel tape directly to the busbar to be monitored.

TECHNOLOGY AND BENEFITS OF THE THM+OZONE+HUMIDITY MEASUREMENT SYSTEM

The ZYGGOT Ozone Detection Protection System, integrated in this product with the Zyggot V5F/TOH THM+OZONE+HUMIDITY Temperature Monitoring Relay, was designed to enable full-time monitoring and predictive protection against arc flash in low, medium and high voltage electrical panels and systems.

OZONE: The ZYGGOT ultra-sensitive ozone measurement protection system introduces an important innovation to the market due to the fact that it detects levels in the order of parts per billion and is networked.

Differential increases in ozone levels trigger an alert for possible checking and predictive maintenance.

Ozone is composed of 3 oxygen atoms (O³) and is a highly oxidizing gas. In gaseous form it is colorless, in liquid form it is dark blue, almost black. Its melting point is 80K and its boiling point is 161K. It has a characteristic odor that can be detected in concentrations as low as 0.015ppm (15 PPB) (0.01mg/kg).

Ozone is produced mainly by the Corona effect (Corona Discharge) or by UV radiation that are present in electrical sparks in an environment with the presence of Oxygen (Air in other words). Its production can be extended to the occurrence of partial discharges in compromised insulating media (due to the existence of emulsified air), which occurs in the case of poor quality of the insulator or its aging. These partial discharges not only increase the Corona level but also directly produce ozone, which ends up leaking into the surrounding air.

Electric arcs in electrical equipment are produced by the reduction of insulation between two electrical conductors or between an energized conductor and ground (panel mass) and also by heating of electrical connections which end up increasing electrical resistance, causing exponential heating of the connection to the point of melting the copper and consequently the opening of an arc due to an abrupt increase in voltage levels in circuits with existing or distributed inductance, since the energy stored in the inductance as $E = LI^2/2$ is converted into high voltage as $E = VC^2/2$ (where c is the distributed capacitance).

HUMIDITY: The increase in relative humidity of the air inside the panel also contributes to reduced insulation. Its variation in relation to time may indicate, for example, that the system is operating without the internal heaters of the panel in operating conditions, or changes in the condition of the air present in the rooms.

TEMPERATURE: THM sensors with an opening angle of 7° (1/8) not only monitor the target (point to be monitored) via infrared, without contact, from long distances, but also allow monitoring of the rise in the internal temperature of the panel, since each sensor also measures the temperature of the surrounding air, thus detecting rises in temperatures and points not directly targeted. The rise in internal temperature in panels, due to fan failure or clogged air filters or even indirect heating through heating of electrical connections, is also an important indicator. Electrical connections not directly monitored by the infrared THM sensor can be indirectly detected by the rise in the internal air of the panel above the historical levels for the panel in question.

BENEFITS

!Monitors, at the same time, with a single relay and a single network of up to 125 sensors and 250 measurements, 4 important variables to avoid future arc flash.

!Detects poor contact due to mechanical failure or oxidation in electrical connections.

!Detects aging of the panel or its insulation.

!High sensitivity for ozone detection.

!The only networked system for ozone detection worldwide (low cost).

!Easy installation and commissioning. Low implementation cost.

!High reliability.

!High alarm selectivity with independent alarms for sensor groups and identification of the sensor sending the alarm.

MAIN FEATURES OF THE SYSTEM

- > Intelligent relay (with color touch screen). User-friendly.
- > Applicable in low, medium and high voltage.
- > Relay with Modbus RTU port for connection to PLC or DCS.
- > Relay with ETHERNET for worldwide monitoring.
- > Intelligent THM and Ozone sensors powered by the network itself.
- > Monitoring of voltages and sensor status.
- > Dispenses with analog interfaces.
- > Sensors and Relays can be configured and tested by PC with free software.
- > Possibility of using only temperature sensors, only ozone+humidity sensors or both, in the same relay.
- > Up to 125 sensors connected to a single Zyggot Relay. (Network with plug-in sensors).
- > Each sensor has an LED that flashes when commanded by the relay, to detect faults or their identification. > Zyggot relay with 4 or 12 programmable digital outputs and 4 digital inputs for external faults, etc., in addition to 4 analog inputs.
- > Easy testing with the system de-energized.

HOW TO ENSURE ACCURATE READINGS ON BODIES OF LOW OR UNKNOWN EMISSIVITY.

For low emissivity bodies, such as polished copper, which has an emissivity of 0.06, it would be very difficult to obtain an accurate reading. This is not a problem for the Zyggot system, because once the Unidex tape is stuck on the area to be measured, the emissivity of the area becomes constant at 0.95. This index, once entered into the relay's memory, becomes the correction index for the measured temperature, also avoiding variations over time, which could occur with oxidation, which would increase the emissivity index. The Unidex tape, on the other hand, is stable and does not vary over time.

If all areas of interest, be it the material, copper, porcelain, PVC, etc., have the reading area covered with the Unidex tape, it is easy to see that when the equipment is started up, before putting it into operation, it can be fully calibrated in a few seconds, simply by programming all the emissivity indexes to the value of the Unidex tape, without having to calibrate different indexes for each material.

On the other hand, low-cost portable meters or even some high-cost ones do not have the possibility of calibrating the emissivity index, which is fixed at 0.95, leading to dubious measurements.

TOPOLOGY DESCRIPTION.

Each sensor has an LED that flashes when commanded by the relay to facilitate diagnosis and check the addressing.

Different alarm and trip levels for the target and body temperatures of the sensor (surrounding air) allow the optimization of the protection system. Each relay can monitor up to 125 Sensors, mixed freely (THM = Target + air) or Ozone (Ozone + Humidity).

The relay automatically indicates sensors that are not responding and also checks the supply voltage level reaching each sensor, allowing the detection of potential problems in the network, such as cabling exceeding the permitted extension.

The THM (thermal) and Ozone + Relative Humidity sensors are connected directly to the Zyggot relay through an interface (V5CON).

The relay's function is to read the target and body temperature values of the sensors, ozone levels and humidity levels in each of the 125 sensors in the system, in addition to the sensor status (supply and communication voltages). Four or twelve digital outputs are available. Four or twelve digital inputs and four analog inputs are also available.

The data transmission method between sensors and relay uses RS-485 physical layer communication, with all sensors connected in parallel using shielded cables with mini-USB connectors that allow quick installation (plug and play) and operation without the need for any tools.

The Zyggot THM+Ozone+Humidity system relay can be connected to a communication network with a supervisory system or remote monitoring.

The ZYGGOT V5F/TOH Relay has Ethernet communication with various protocols, and can be accessed from anywhere by mobile or non-mobile devices.

ZYGGOT V5F/TOH Relay.

- **Programming of parameters and values:** "On line".
- **Reading of Values:** Temperature of each target, Temperature of each sensor body (surrounding air), Ozone level in the air in each sensor, Relative humidity of the air in each sensor, Power supply voltage of each sensor, Analog inputs.
- **Communication:** Serial RS232C and RS485 MODBUS RTU protocol for "Point to Point" connection, for use in network (Droop Out). CAN port with Devicenet protocol (Optional).
- **Protections and Indications:** Alarm and/or Trip due to target over-temperature, Alarm and/or Trip due to differential heating of targets, Alarm and/or Trip due to elevation of Ozone levels. Alarm due to high relative humidity levels, Communication failure with the THM and Ozone sensor network, Modbus communication failure, Sensors not responding, Alarm and/or Trip due to over-temperature of the sensor body (surrounding air), Alarm and/or Trip for up to 5 groups of independent sensors, Alarm and/or Trip due to external failure, Alarm and/or trip due to analog input levels, Alarm due to memory card failure, Active alarm screens, History screen with "Time Stamp", Bargraph with sensors being read, Alarm and trip statistics, Digital input and digital output status, Analog input levels, Temperature plot for each sensor and analog input, Indication of Temperature Differential and Ozone level.
- **Fault actions:** Programmable for each fault in "None", "Log", "Alarm", "Trip".
- **Real Time Clock:** Included.
- **Fault History:** with Date and Time (Time Stamp).
- **Event Memorization:** Unlimited events, memorized indefinitely until they are cleared with a password, for security.
- **Programmable Digital Outputs:** 4 on the Zyggot relay plus 8 on the optional EBLOCK module.
- **Programmable Digital Inputs:** 4 on the Zyggot relay plus 8 on the optional EBLOCK module.
- **Fail Safe System:** Yes
- **Memory Card:** Automatic and manual recording of temperature and ozone reading data on the memory card for transfer to computers.
- **Active Screens:** Over 200 user-friendly multiple touch screens.
- **Parameter Programming:** By the relay itself, with passwords, by PC software (Free), by replication via memory card (program one and replicate it in all relays in the system) or by Modbus.
- **Multi System:** Can be used only with THM sensors (temperature), only with Ozone + Humidity sensors or both.

MEASUREMENT AREA, EMISSIVITY, MEASUREMENT ANGLES.

Areas as a function of distance for the 7th sensor
Area diameter = Distance / 8

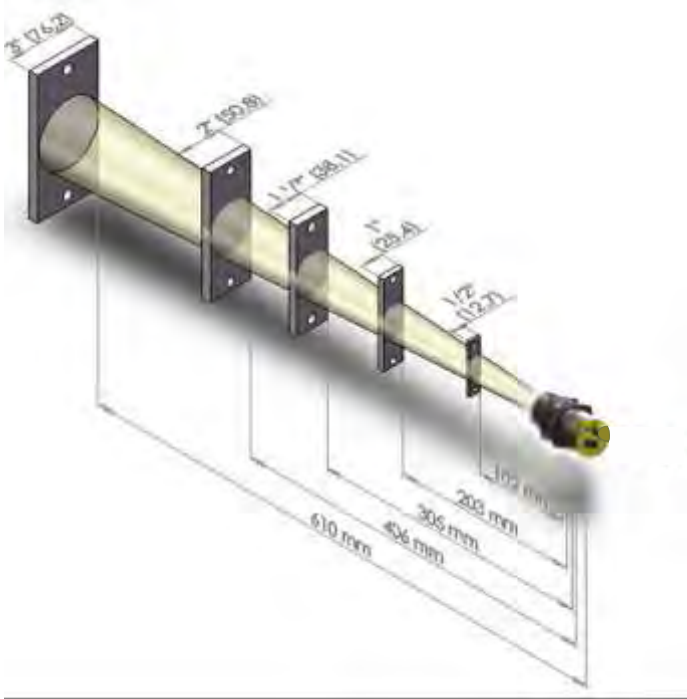

AVAILABLE READING ANGLES.

The THM Tubular Sensor is supplied with a standard reading angle of 7° (other angles can be supplied on request).
 The BT Sensor has a measuring angle of 120°

Perfect aiming of the object is guaranteed with a removable laser sight.

You can measure objects up to 10 meters away with automatic compensation.

Reading errors, which can occur and usually go unnoticed, with measurements using manual guns or even thermographic cameras due to differences in the emissivity of the materials.

With the Zyggot sensor pointing at a Unidex tape or even a copper busbar coated with heat shrinkable (which has an emissivity of 0.95 like the Unidex tape), you get an accurate temperature reading, since the sensor is calibrated to 0.95

In short, it is not possible to rely on manual non-contact measurements when dealing with multiple materials, without calibrating the meter for each type of emissivity.

The Zyggot system solves this problem and also provides real-time measurements.

SELECTION OF CABLE LENGTH FOR EACH SENSOR.

The tubular sensors are connected by a shielded multi-cable with mini USB connectors at both ends. Each sensor has 2 mini USB connectors, making it easy to chain one sensor to the next and so on up to the relay. The connection cables are supplied in different lengths to facilitate installation. The use of ZTA shunts facilitates installation and can be used freely.

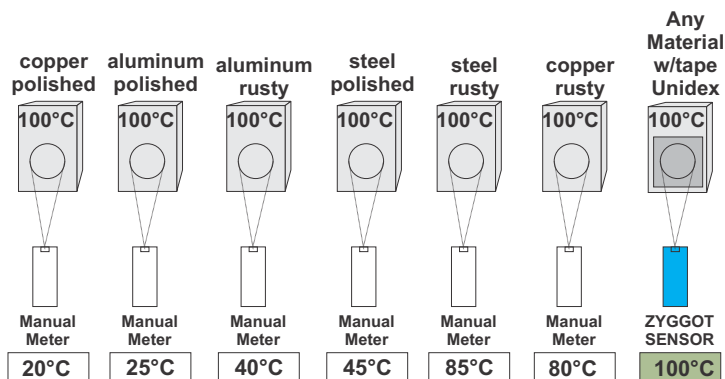

CAPTURING THE TEMPERATURE MEASUREMENT AND INFLUENCE OF EMISSIVITY

Every object with a temperature above absolute zero radiates electromagnetic energy. This radiation in the infrared range is not visible, as can be seen in the figure below.

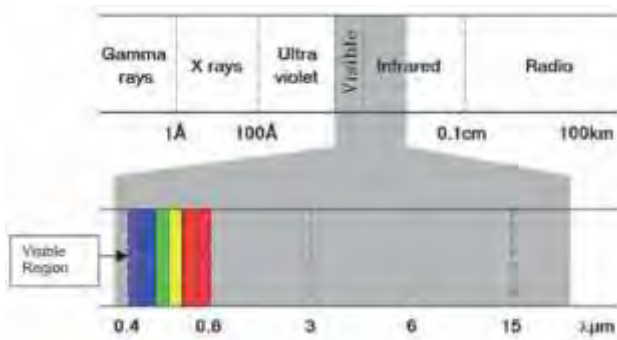

When radiation from one object reaches another object, some of the energy is absorbed, some is reflected, and if the body is not opaque, a portion is transmitted. The sum of the parts must always be equal to the total value that fell on the object. In view of these facts, in order to capture the temperature of desired targets, you must have sensors that capture such electromagnetic energy.

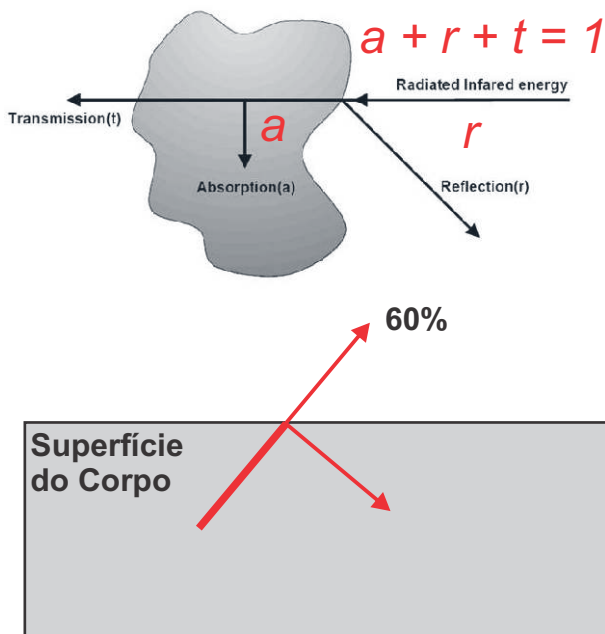

When a material is heated, its surface does not absorb all the energy and ends up emitting infrared energy. In practice, there is no material that is an ideal emitter of infrared radiation. The ideal emitter is called a black body. Objects tend to radiate less energy than black bodies even though they are at the same temperature.

The emissivity of an object is defined by: $\epsilon = t/b$

ϵ = Emissivity;

t = Radiation emitted at a certain temperature;

b = Radiation emitted by a black body at the same temperature

The table below shows the emissivity range for various materials.

MATERIAL	EMISSIVIDADE (1µm)
Iron and Steel	0,35
Iron and oxidized steel	0,85
Aluminum	0,13
Oxidized Aluminum	0,40
Polished copper	0,06
Oxidized copper	0,80
Brick	0,80
Asphalt	0,85
Asbestos	0,90

There are some portable meters that do not have the possibility of varying the emissivity index, which leads to erroneous measurements since this index is fixed at 0.95. Zyggot sensors allow emissivity index configuration, ensuring accurate measurements on any material

UNIDEX TAPE

Solution for emissivity variations

Most metals have a change in emissivity due to oxidation. An example is copper, which under normal conditions has an emissivity of 0.06 and 0.80 when oxidized.

To avoid emissivity calibration readjustments of the sensors, the Zyggot System includes the supply of a special adhesive tape for temperatures up to 250°C, whose emissivity value of 0.95 is known and guaranteed by Varixx. With the Unidex tape glued over the measurement area of a target to be measured, we will always obtain the real temperature reading, without having to worry about the emissivity of the material.

Using the tape, it is not necessary to calibrate different indexes for each material.

The tape is supplied in dimensions of 50mm x 50mm or in a roll of 30m. For each sensor purchased by the customer, a tape drive is shipped.



UNIDEX TAPE
ROLL
(30 meters)

units de
UNIDEX TAPE
50m x 50m
(ref. Zu50)

TEMPERATURE MEASUREMENT AND PRODUCT COMPOSITION

POSITIONING OF SENSORS AND TEMPERATURE READING

Each sensor measures both the target's temperature and body (air) temperature at the same time.

For the correct positioning of the sensors in the pre-defined configuration area the laser is aimed at the front of the sensor and the laser light is directed to the center of the area, as shown in the figure.

A positioning area must be defined on the desired target, having the diameter of the area defined by the sensor distance. The distance between a setup area and the sensor is a maximum of 8 times the setup area diameter value for 7° sensors. The maximum indicated distance to the target must be less than 2 meters. With the distance between the sensor and the target defined, you must enter the distance parameter in the sensor using the configuration software, which is better explained later on.

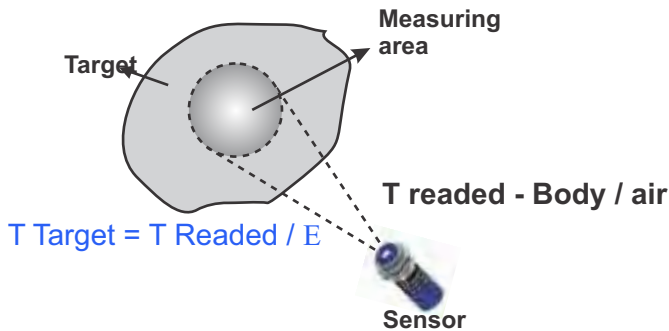

SIGHT ANGLE

Sight angle is the angle between the perpendicular of the target area and the axis that crosses the sensor longitudinally.

The curve below shows that the emissivity would only begin to decrease after an angle of 55° in relation to the perpendicular of the measured object. It is recommended to use a maximum viewing angle of 45°

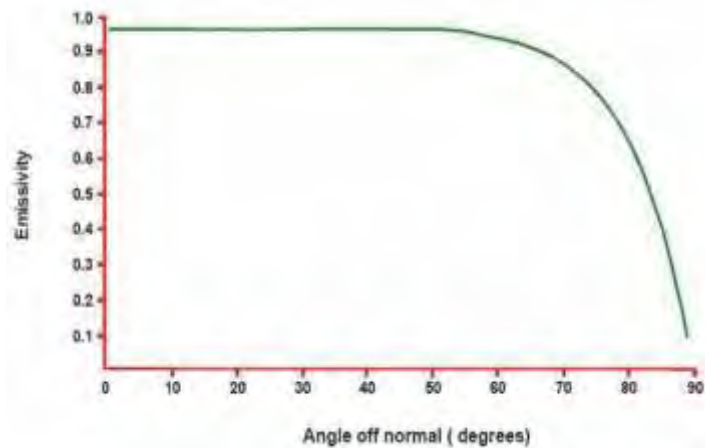

Power supply

The Zyggot Tube Temperature System must be powered from an external source. The VPS12024 source is capable of supplying the 24 VDC needed to power the relay and sensors.

Input: 90~132 / 180~264 VCA // 120~375 VCC

Output: 24VCC/5A - 120W

ZTA Derivator

The ZTA derivator (T connector) makes it possible to enable various types of topologies and layouts, facilitating the installation of the system. For more information, see pages 9, 10 and 11.

Mini USB Cables

mini USB cable

The mini USB cable performs the communication between sensors and sensors/relay.

Cables are available in the following sizes:

0,3m - ZCB/4/2U/030

0,5m - ZCB/4/2U/050

1,0m - ZCB/4/2U/100

2,0m - ZCB/4/2U/200

4,0m - ZCB/4/2U/400

6,0m - ZCB/4/2U/600

8,0m - ZCB/4/2U/800

INSTALLATION AND MAINTENANCE CASE

The Zyggot Temperature Installation and Maintenance Case (ref. VLP5) contains essential tools for installing and maintaining the sensors and relay.

Such tools are: laser sight (ref. VLP2) and USB configuration cable. It is important that this case is in the possession of the Zyggot Temperature System user, in order to carry out any maintenance properly.

Laser sight

The laser sight is an essential tool to direct the sensor to the desired target. The sight makes installation easy.

Configuration Cable (USB)

The USB configuration cable (ref. ZCC180) is used to connect the tubular sensor to the PC. Allows the configuration of each sensor by the Zyggot manager software

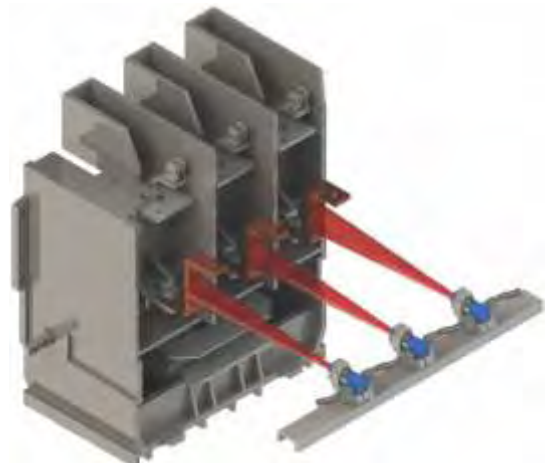

PROTECTIONS AND COMPENSATION OF EMISSIVITY WITH UNIDEX TAPE

FACTORS THAT INFLUENCE THE ACCURACY OF TEMPERATURE READINGS AND ZYGGOT SYSTEM

- * Wave-length → ✓ Sensor calibrated in the optimal range
- * object surface → ✓ Automatic emissivity correction
- * Sight angle → ✓ Up to 60° without error introduction
- * sensor temperature → ✓ Readed and corrected internally

FUNCTION TABLE

ANSI	DESCRIPTION	TRIP	ALARM	Monitor
94	2 x Assignable External			
49	125 Target Overtemperature			
49	125 Case / Air Overtemp.			
49	125 Ozone Level Overpassing			
49	125 Relative Air Humidity Overp.			
48	Trip / Incomplete Sequence			
30	Anunciator w/ Time Stamp			
	Event Recorder - 120 Tags			
	Readings 4 External Analog Signal			
	Readings - 125 Target °C			
	Readings - 125 Case / Air °C			
	Readings - 125 Ozone Level (PPB)			
	Readings - 125 Relative Air Humidity			
	Trendings - Real time curves			



Unidex adhesive tape

In the photo you can see a roll of Unidex adhesive tape, with known and constant emissivity, from room temperature to 250°C, which can be cut and glued in the areas of interest, guaranteeing accurate readings. If the target material has low emissivity, stick the Unidex tape supplied with the sensor to cover the area to be measured. If you do not use Unidex tape, take into account the emissivity index of the target, according to table 1 or by comparison, when programming each emissivity index in the sensor. The use of Unidex tape is recommended for ease of calibration and better accuracy of readings.

The perfect sight of the object is guaranteed with aim Removable laser.

LASER SIGHT

Once the sensors are installed, the pointing direction must be checked, precisely at the target. For this, a laser sight is used, which is supplied as an accessory, in a case that contains the sight and battery power supplies. The Laser sight must be screwed onto the front of the sensor. Once correctly aimed at the target (if using a special bracket supplied as an accessory, this adjustment is very easy). Once the correct sight has been checked, the screw support is removed. If the sensor is relatively close to the target this process can be dispensed with, if the support has been designed correctly to already have a correct position.

Briefcase with Laser Sight (used for the Tubular sensor)



SYSTEM DETAILS RELATING TO SENSORS

SELECTING CABLE LENGTH OF EACH SENSOR AND THE NEXT

The sensors are connected to the network using a shielded sleeve-type cable, without the need for any tools. These cables, which already have a mini USB connector on both ends, are supplied by Varixx in various lengths.

Below are the available codes and sizes.

CODE	CABLE LENGTH
ZCB/4/2U/030	CONNECTION CABLE WITH 0.3 M
ZCB/4/2U/050	CONNECTION CABLE WITH 0.5 M
ZCB/4/2U/100	CONNECTION CABLE WITH 1 M
ZCB/4/2U/200	CONNECTION CABLE WITH 2 M
ZCB/4/2U/400	CONNECTION CABLE WITH 4 M
ZCB/4/2U/600	CONNECTION CABLE WITH 6 M
ZCB/4/2U/800	CONNECTION CABLE WITH 8 M

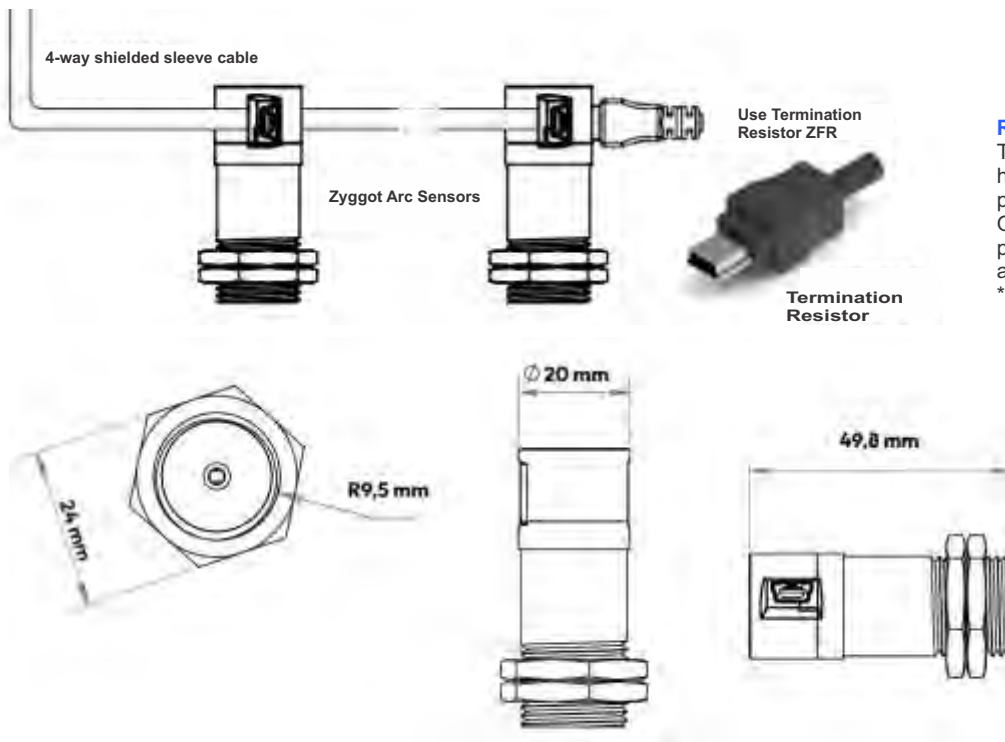

ROBUST CONSTRUCTION.

THM sensors are made of stainless steel and have a Faradex* polycarbonate back, with steel particles in their composition for perfect bling. Ozone and BT sensors are built with a polycarbonate body that is resistant to impacts and high temperatures.

* SABIC Trade Mark

PROGRAMMING THE SENSORS

- 1 - Download and install the free software "Zyggot Arco Configurador" from the Varixx website (<http://www.varixx.com.br>).
- 2 - Open the configuration program.
- 3 - Connect the sensor to the computer's USB port using a mini USB / USB cable (connect one sensor at a time). When the sensor is connected, its back light will turn on. The program automatically detects the sensor. If this does not happen, you can choose manual connection, choose the serial port corresponding to the USB to which the sensor cable is connected and press the «Connect» key to attempt a connection. When connecting (in both manual and automatic mode), a green light will turn on in the program indicating that the connection was successful.
- 4 - Program the sensor address (from 1 to 125) in the corresponding window and press «Send» to save the information to the sensor. Disconnect the sensor by simply removing it from the cable.
- 5 - It is advisable to label the sensor with its programmed address to make it easier to assemble in the field. If you wish to configure another sensor, return to step 3. Then make sure that no addresses are duplicated between the sensors.
- 6 - Once all sensors have been programmed with their addresses, fix the sensors in the defined positions using the two nuts on the front of the sensor. As a suggested assembly method, we recommend using our metal "adjustable fixing bracket" (REF. ZSF2), with adjustable angle, which allows the use of just one Boelhoff rivet or similar in the chosen location to fix the sensor and direct it.

PROGRAMMING SENSORS WITH ZYGGOT SUPERGER SOFTWARE

SENSOR AND RELAY PROGRAMMING WITH SUPERGER

Zyggot SUPERGER is a configuration software that performs the addressing and testing of sensors as well as the parameterization and configuration of the relay. The software is available for free download through the Varixx website (<http://www.varixx.com.br>). The figure below shows the home screen of the ZyggotArco software.



Never connect two sensors to the PC



The software automatically recognizes the device and the port to which it is connected to the computer. If the port is not recognized, you can manually select the port using the Manual Connection box. When choosing to connect manually, you must select the serial port to which the device is connected and press the Connect button. When a sensor is connected to the computer, the program screen automatically changes to the image below. When connecting a sensor, the program automatically reads the address settings.



To set a new address for the sensor, you must change the sensor number in the Sensor tab. When you do this, the sensor number will flash red, indicating that the change has not yet been sent to the sensor. To save the change, press the Send button.

COD: V5F/TOH



RELAY 96 X 125 Touch Screen

Technical information

FEATURES: V5F/TOH

Power Supply	24 VDC
Humidity	5 to 95%
No. of sensors	up to 125 sensors
Resolution	1°C
Inputs	4 analog 4 digital (12 to 24VDC)
Outputs	2 Alarm and Trip outputs (N.O.) 2 programmable outputs (N.O.) 1 output for connection to sensors
Communication	Modbus RTU Devicenet (optional) Ethernet TCP-IP (optional)
Screen	Color, Touch Screen WVGA

COD: V5CON
(Includes in each Relay Supplied)



INTERFACE

COD: ZST/M/7/300/24



THM TUBULAR SENSOR

Technical information

FEATURES: EBLOCK 88x (x=D or x=R)

Power Supply	24 VDC (10 - 30 VDC) 2W
Moisture	5 to 95%
Communication	CAN
Temperature	Oper: 0 to 60 °C /// Armaz: -10 to +60 °C
Inputs	8 Digital Inputs (12 - 24 VDC)
Outputs	Model 88D = 8 Digital Outputs (DC) Model 88R = 8 Digital Output (Relay)
Inputs	Imp.: 10K /// Treshold: 8 VDC / 3 VDC
Distance Max	1000 M
Output Current (Model 88D)	2,5 A Max per point /// 10A Total Max (model 88D)
Output (mod 88R)	3,0 A @ 250 VAC Res. Max (mod. 88R)

Informações Técnicas

FEATURES: OZONE SENSOR

Measuring range O ³ :	0 - 2000 ppb
Typical reading error (*):	+/- 1%
Sensitivity O ³ :	< 5 ppb
Humidity Range:	0 - 100%
Resolution O ³ :	0.1 PPB
Humidity Resolution:	0.1 %
Humidity Sensitivity:	< 2%
Power Supply:	24 Vdc
Diameter:	54 mm
Length:	31,2 mm
Communication:	Modbus RTU
Material:	Polycarbonate

COD: ZSB/M/60/120



SENSOR THM BT

Technical information

FEATURES: THM TUBULAR SENSOR

Measurement angle:	7°
Typical read error (*):	+/- 0,5°C (trg: 0-125°C)
Normal Distribution (100 s):	0.48°C at 80°C target
Emissivity:	Programmable (0,95 std)
Resolution:	1°C
Target reading:	0 to 300 °C
Environment reading:	0 to 75 °C
Power:	24 Vcc
Diameter:	19 mm
Length:	53 mm
Communication:	Modbus RTU
Material:	Stainless Steel / Polycarbonate

(* See test report at the end of this manual)

Technical information

Connectors: EB/88D & EB 88R

1:	Digital Outputs / Relay Outputs
2:	NET address selection switches
3:	LEDs de status
4:	Inputs
5:	CAN & Power Supply
6:	Ground
7:	CAN RJ45

COD: ZSO/2000



OZONE SENSOR

Technical information

FEATURES: BT SENSOR

Measurement angle:	120°
Typical read error (*):	+/- 0,5°C (trg: 0-125°C)
Normal Distribution (125 s):	0.48°C at 80°C target
Emissivity:	Programmable (0,95 std)
Resolution:	1°C
Target reading:	0 to 120 °C
Environment reading:	0 to 75 °C
Power:	24 Vcc
Diameter:	54 mm
Length:	31 mm
Communication:	Modbus RTU
Material:	Polycarbonate

(* See test report at the end of this manual)

ACCESSORIES

Accessory

COD: VPS6024 ou VPS12024



POWER SUPPLY

Accessory

COD: ZSF2



Support for fixing and sight for tubular

Accessory

COD: VZX/B1/U ou VZX/B1/U/P



SUITCASE WITH LASER SIGHT

Accessory



Y-split Derivator, USB cables and terminating resistor

Accessory

COD: VLP2



Laser sight attachable to tubular sensor for startup

Accessory

COD: ZA232-2



SPLIT RS232

Accessory

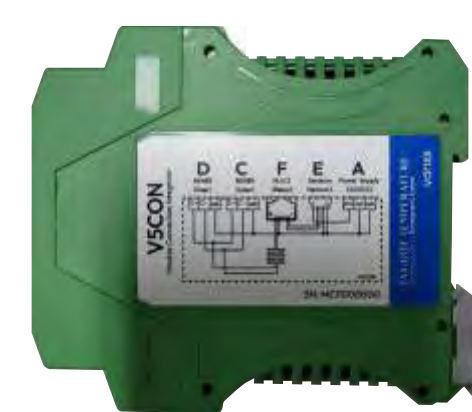

COD: V5CON
(Comes with each Relay)

INTERFACE

Accessory

COD: RJ45/C2
(Comes with each V5CON module and each Eblock)



RJ45 CABLE

COD: EB/88D ou EB/88R
(For use with V5FTA relay)

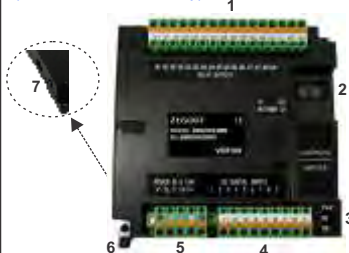

EBLOCK (Optional Use)

Included with every BT sensor

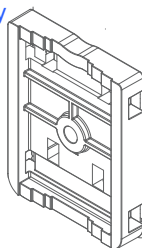

Quick Fixing Base for BT Sensor

V5CON AND EBLOCK INTERFACE DETAILS



The V5CON interface simplifies the connection of the Zyggot V5FTA relay to the sensor network, power supply and also integrates the sensor network termination resistor at the end of the relay and two RS232C to RS485 converters, more suitable for long distance communication. It must be installed on a quick fixing rail at the base in the same cubicle where the Zyggot relay is installed.

V5CON INTERFACE CONNECTIONS (All on top)

Port A (Power): Connection for the system's 24 VDC power supply. VPS6024 OR VPS 12024 power supplies.

Port F (Relay): Connection with RJ45 cable between the Interface and the Zyggot relay.

Port E (Sensor Network): Connection with cable and mini USB connector between the Interface and the sensor network.

Port C (RS485): RS485 serial connection between the relay and the user's DCS system.

Port D (RS485): RS485 serial connection between the relay and the user's DCS system.



Label

V5CON Interface

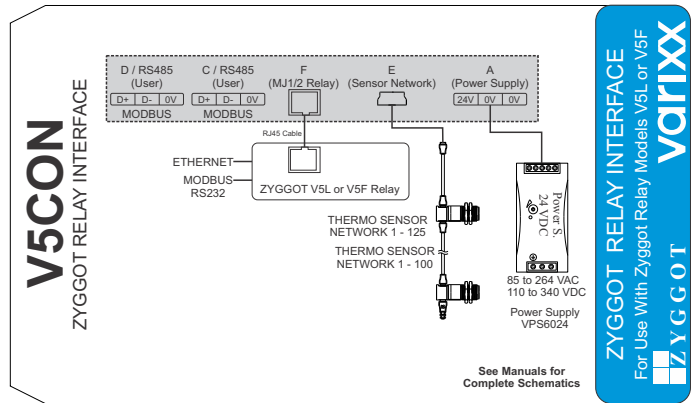
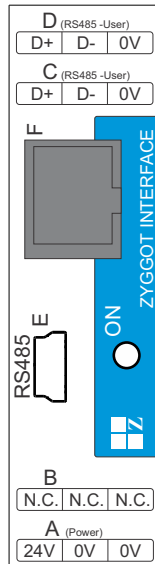

The **EBLOCK 88D** module adds 8 digital outputs and 8 programmable digital inputs to the Zyggot V5FTA relay.

The **EBLOCK 88R** module adds 8 relay outputs (dry contacts) and 8 programmable digital inputs to the Zyggot V5FTA relay. These modules are optional.



EBLOCK 88R

Digital Outputs		
D. OUT. 1	ALARM	Q1 RELAY
D. OUT. 2	TRIP	Q2 RELAY
D. OUT. 3	D.O. 3	Q3 RELAY
D. OUT. 4	D.O. 4	Q4 RELAY
D. OUT. EB1	AUX 1	Q1 EBLOCK
D. OUT. EB2	AUX 2	Q2 EBLOCK
D. OUT. EB3	AUX 3	Q3 EBLOCK
D. OUT. EB4	AUX 4	Q4 EBLOCK
D. OUT. EB5	AUX 5	Q5 EBLOCK
D. OUT. EB6	AUX 6	Q6 EBLOCK
D. OUT. EB7	AUX 7	Q7 EBLOCK
D. OUT. EB8	AUX 8	Q8 EBLOCK

Digital Inputs		
D. INP. 1	EXT. F. 1	I1 RELAY
D. INP. 2	EXT. F. 2	I2 RELAY
D. INP. 3	MUTE	I3 RELAY
D. INP. 4	RESET	I4 RELAY
D. INP. EB1	AUX 1	I1 EBLOCK
D. INP. EB2	AUX 2	I2 EBLOCK
D. INP. EB3	AUX 3	I3 EBLOCK
D. INP. EB4	AUX 4	I4 EBLOCK
D. INP. EB5	AUX 5	I5 EBLOCK
D. INP. EB6	AUX 6	I6 EBLOCK
D. INP. EB7	AUX 7	I7 EBLOCK
D. INP. EB8	AUX 8	I8 EBLOCK



Detail of the EBLOCK RJ45 connector for communication with the relay (CAN)

ONE WIRE DIAGRAM USING EBLOCK AND MAIN FEATURES

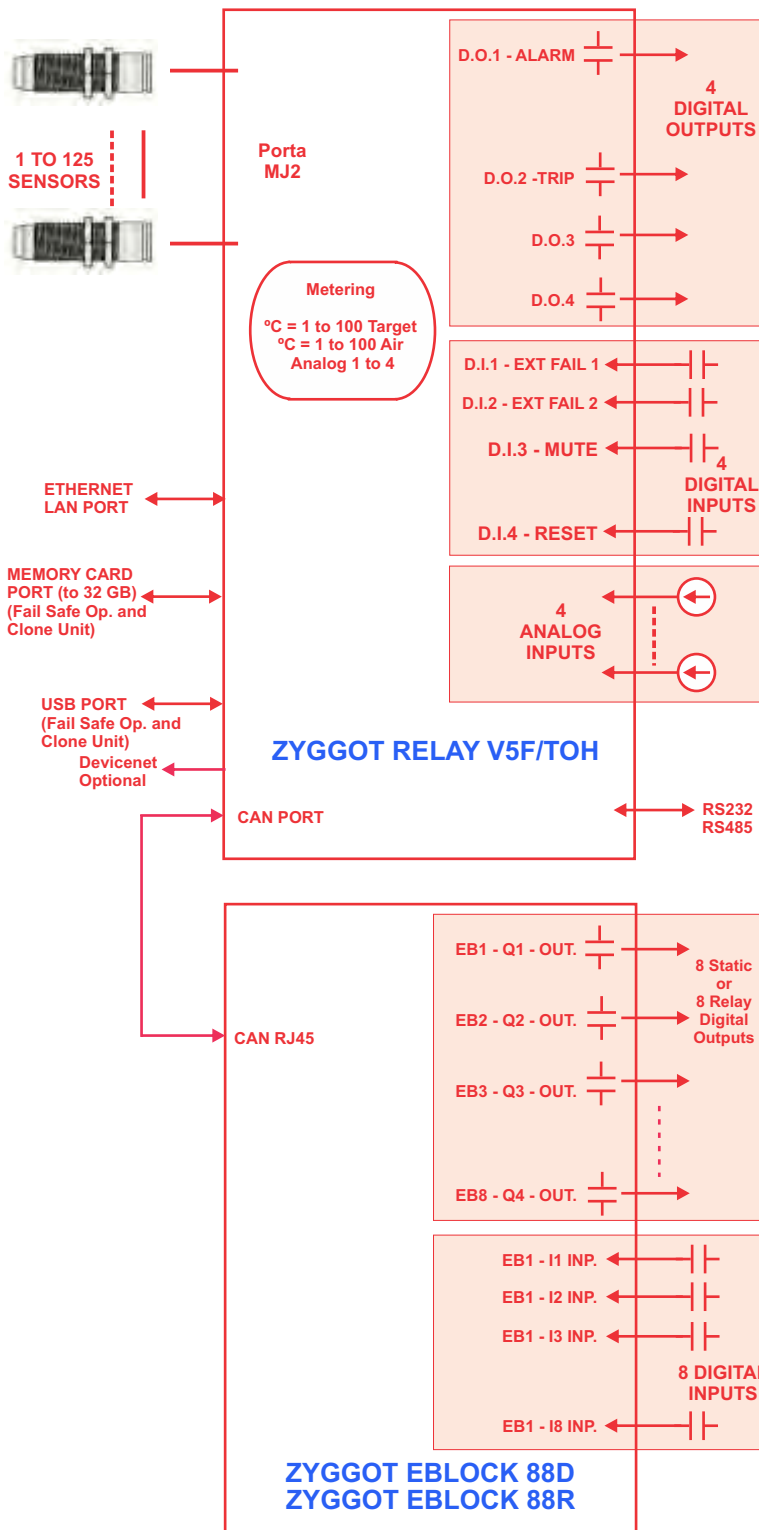

Measurement

The Zyggot Relay provides accurate measurement of:

- Up to 125 target or area temperatures (0 to 300°C).
- Up to 125 surrounding air temperatures (0 to 100°C).
- Up to 125 ozone levels (0 to 2000 ppb).
- Up to 125 relative humidity levels (0 - 100%).
- Up to 125 sensor supply voltage levels (24VDC nominal)
- 4 12-bit analog inputs for measurement and protection of external variables, such as other temperatures acquired by thermocouples and others
- Operating Hours.
- Sensor integrity in the network (Not Responding or OK and supply voltage)

Display

Touch Screen graphic display, with trending capability. Trending shows in real time in graphs of up to 3 sensors per screen the real behavior of any temperature or analog input. 64k colors.

Aiming tool

A laser pointer can be screwed onto the front of the sensor body only during installation, allowing quick and safe attachment of the sensors, then being removed. A single pointer is both necessary and sufficient.

Programming tools

A free program developed with graphical windows is provided free of charge by Varixx to further facilitate the parameterization of the relay. Even without this program, it is very easy to parameterize the relay via the HMI, with interactive and user-friendly menus. Another program tests and parameterizes each sensor (emissivity and address).

You can also clone one relay to another.

Event memory

The relays allow the memorization and indication of the last 120 faults with date and time of occurrence. These indications are not lost even if the relay is turned off.

Communication ports

The ZYGGOT V5F/TOH relay has 1 RS232 or RS485 programmable communication port with converter, which can be used for communication with supervisory systems or PLCs with Modbus RTU communication protocol. Another CAN port with CsCAN or Devicenet protocol (Optional) allows communication and expansion.

There is a USB port and a Memory Card port up to 32 GB. An ETHERNET LAN port is also available.

Analog Inputs

The Zyggot V5F/TOH relay has 4 12-bit analog inputs that can be used for measurement and protection, linked to external temperature and other transducers.

Digital Inputs

Zyggot V5F/TOH relays have 4 configurable digital inputs, which can for example be connected to panel door micro switches or ventilation airflow sensors.

Digital outputs

4 digital static outputs are available on the relay and 8 digital static outputs (model Eblock 88D) or 8 relay outputs (dry contact) (model Eblock 88R), all configurable for alarm or trip, to indicate any of the faults. Digital outputs are available to indicate any of the faults.

Topology

Tubular sensors allow quick and easy installation and parameterization.

TYPICAL CONNECTIONS

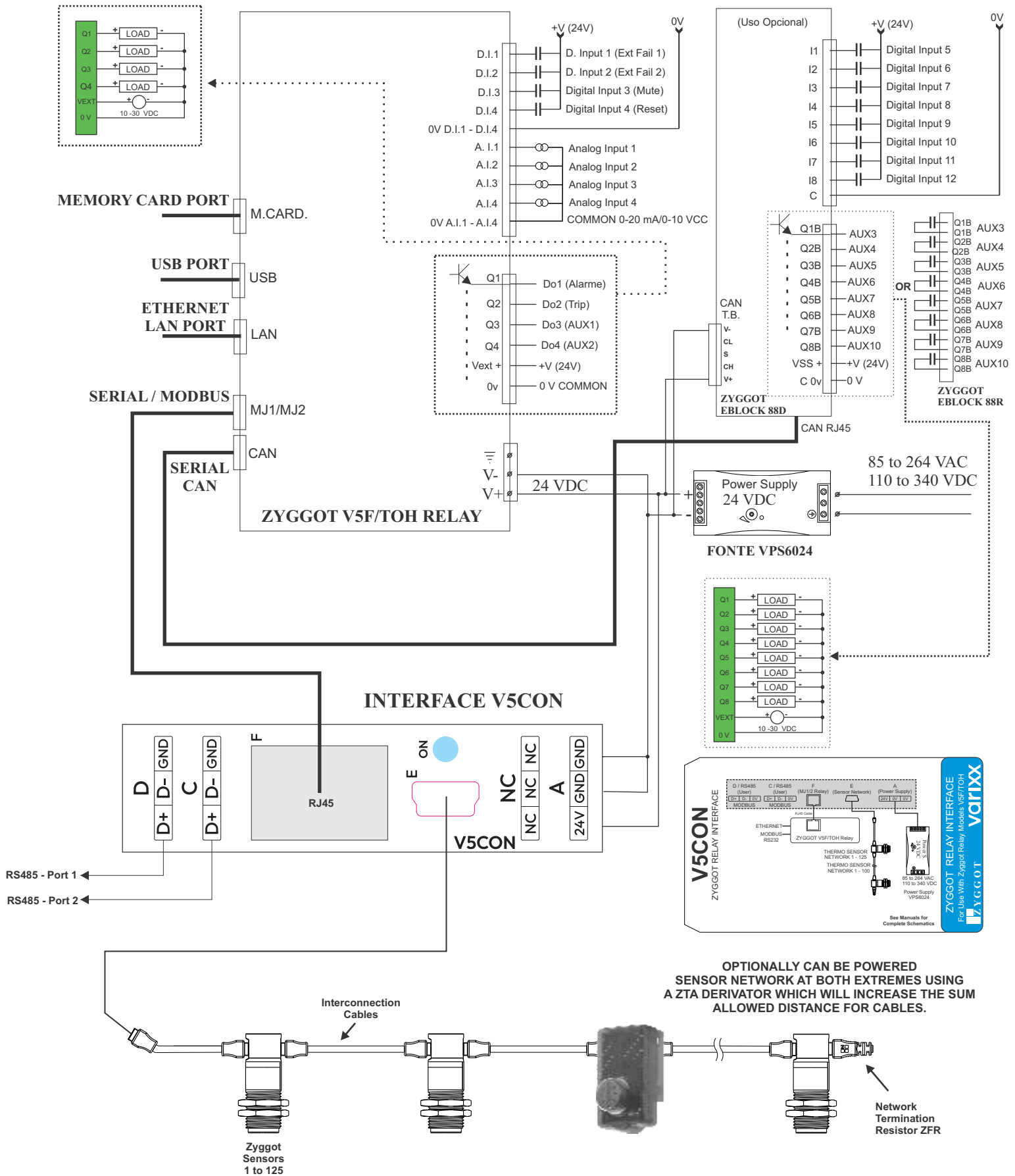

CONNECTIONS

External Fault Connection Usage Example

ZYGGOT THM+O+H



ZYGGOT ARC RELAY



USING ZYGGOT ARC RELAY TOGETHER

You can also use the Zyggot normal arc relay connected to the V5F/TOH. You can connect one or two Zyggot Arc relays for protection against electric arcs by detecting ultraviolet light connected to the external fault input 1 and/or 2 for real-time history purposes. Each Zyggot Arc Relay can monitor up to 50 sensors and as one sensor is normally used per cubicle, up to 50 cubicles can be protected by each Zyggot arc relay.

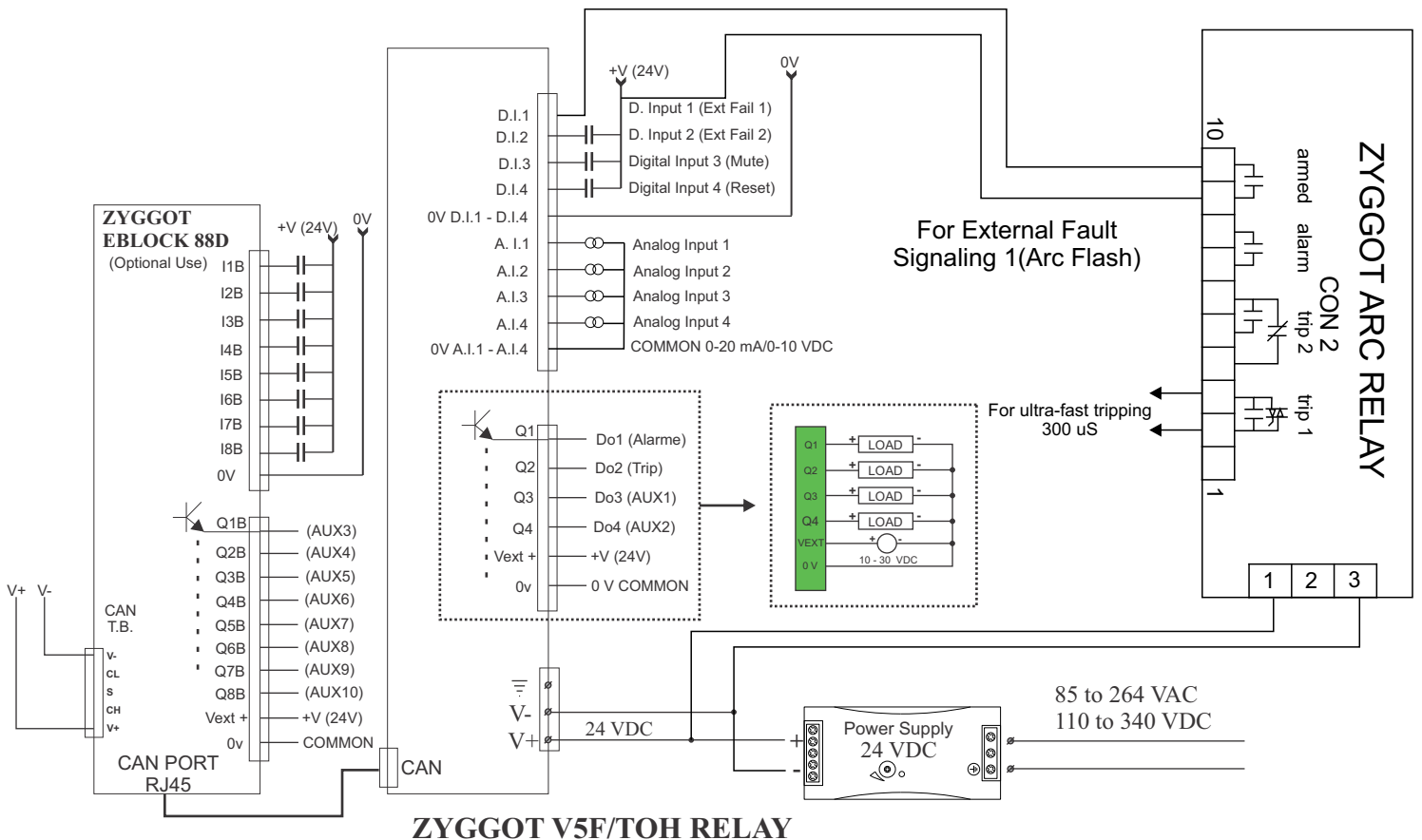

TYPICAL INTERCONNECTIONS

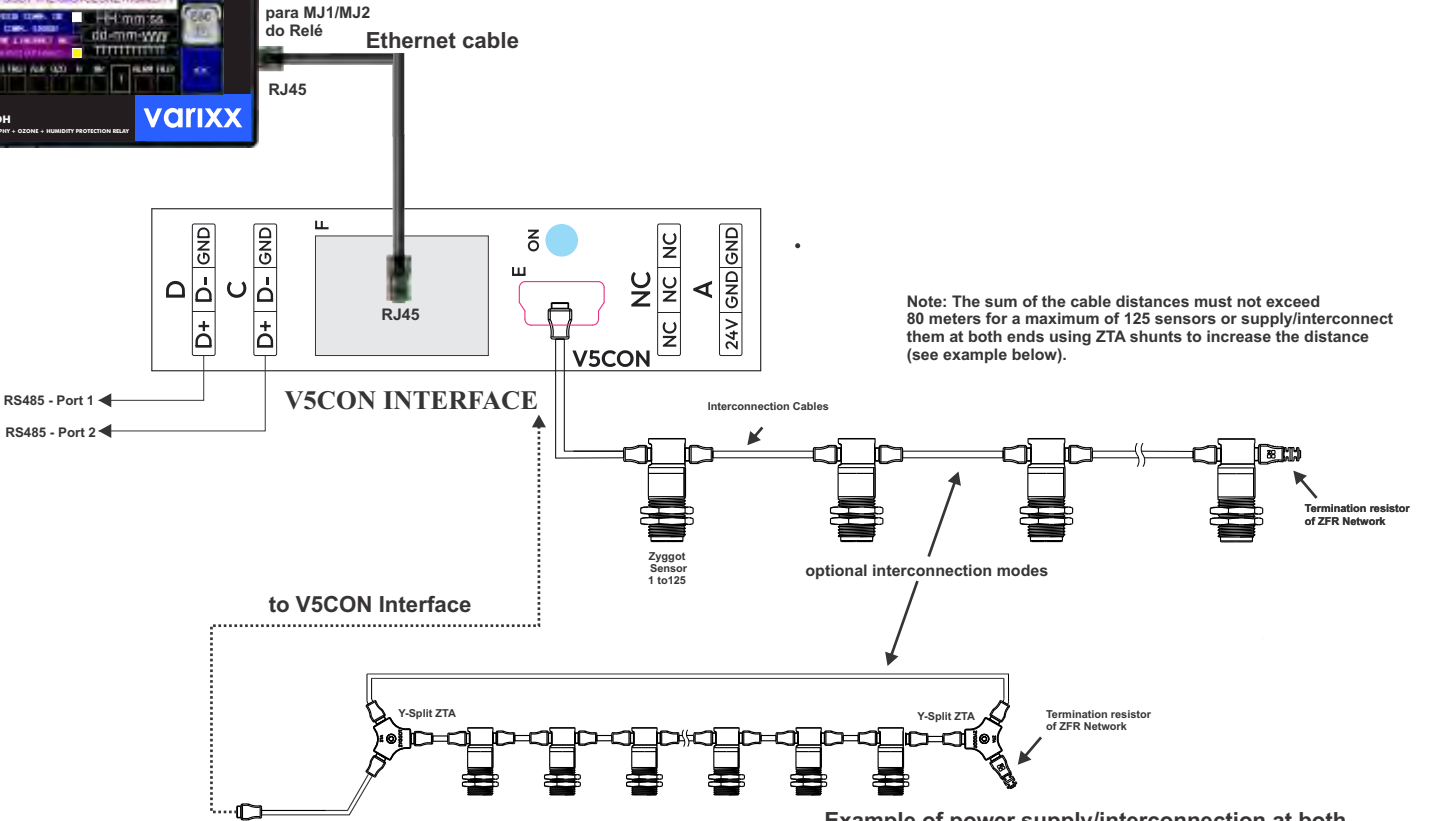
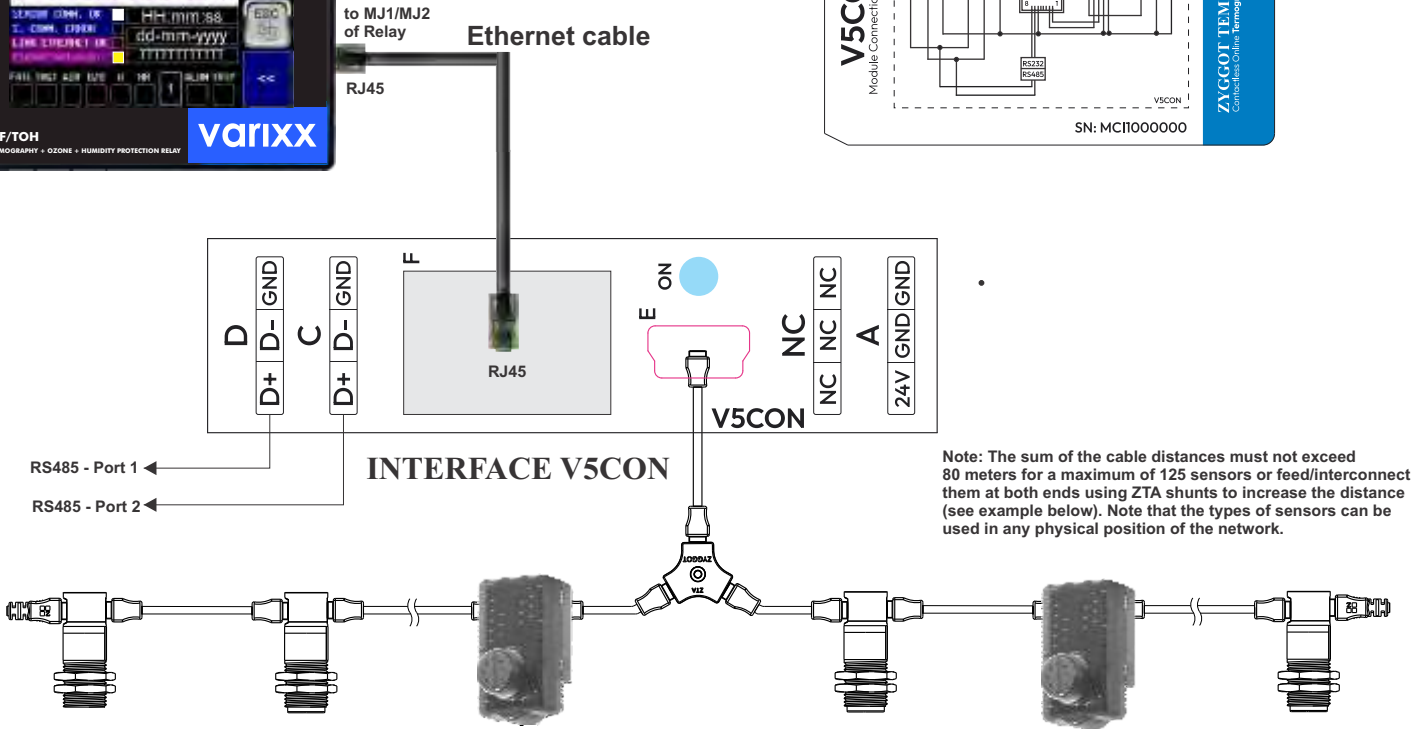
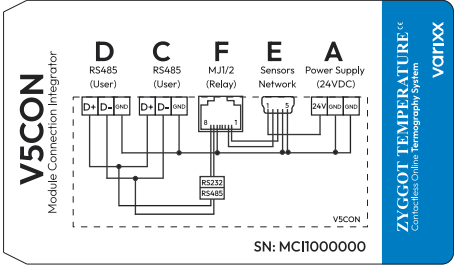

Example of power supply/interconnection at both ends in order to increase the distance of the cables to twice what can normally be achieved.

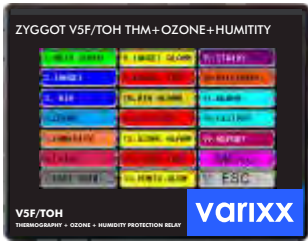

TO MJ1/MJ2 of Relay
Ethernet Cable
RJ45

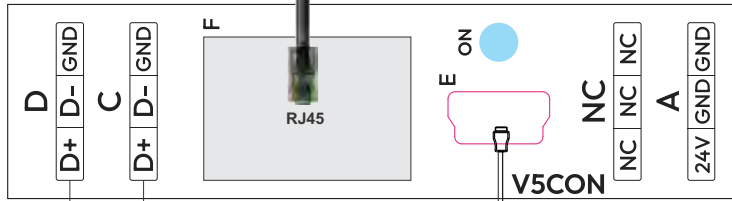
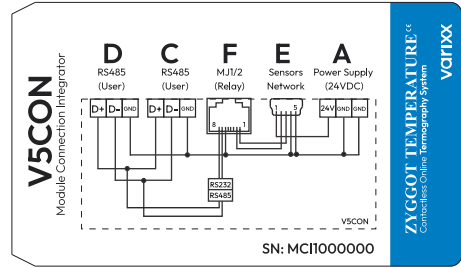

RS485 - Port 1
RS485 - Port 2

V5CON INTERFACE

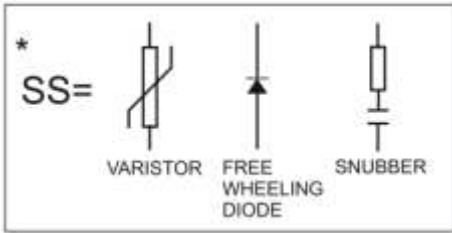

TRANSIENT SUPPRESSOR IN TRIP CONNECTION

It is mandatory to use a type of transient suppressor compatible with the type of load. For trip coils (highly inductive), it is recommended to use a Varistor with appropriate characteristics. Possible variations for this circuit are "Free Wheeling Diode" (for DC power) and "Snubber" circuit composed of Resistor and Capacitor. This minimizes the generation of arcs in the 52a contact of CB1 and noise, increasing the useful life of the system and avoiding interference and improper operation of other equipment. If in doubt between the types of circuit, use the varistor. Consult the Circuit Breaker Manual.

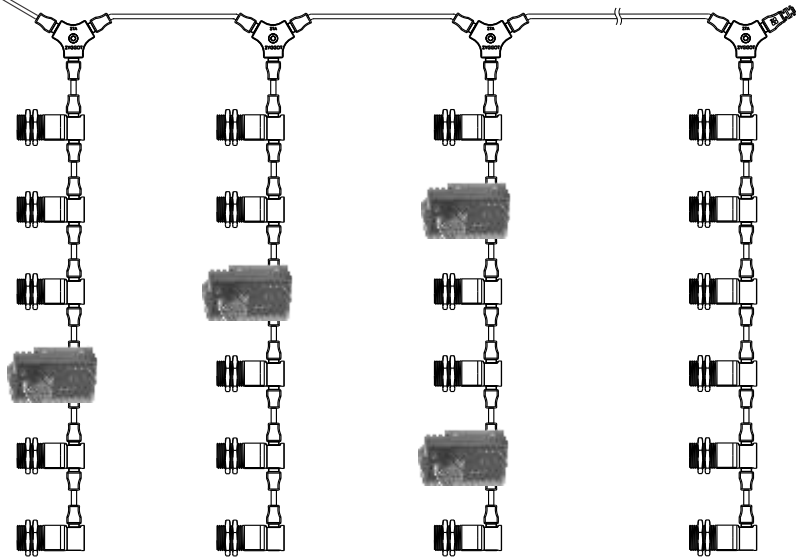

Note: The sum of the cable distances must not exceed 80 meters for a maximum of 125 sensors or supply power from both ends to increase the distance. Note that the sensor types can be used in any physical position of the network.

MECHANICS



- 1- POWER 24 VCC
- 2- D.I. / A.I. CONNECTOR
- 3- D.O. / AQO. CONNECTOR
- 4- CAN PORT
- 5- RS232/RS485 SERIAL PORTS
- 6- CONFIGURATION SWITCHES
- 7- ETHERNET LAN PORT
- 8- MICRO SD SLOT
- 9- USB PORT

PANEL CUTOUT

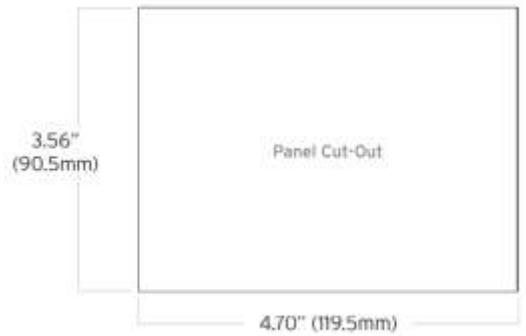

ZYGGOT V5F/TOH THM+OZONE+HUMIDITY

1. WITH SCREEN	4. FRESH FLANK	15. SWIRLED
2. FRESH	8. RICH FLANK	16. DAZZLED
3. RIR	9. RIR ALMAH	17. FLANK
4. RIR	10. RIR ALMAH	18. FLANK
5. HUMIDITY	11. RICH FLANK	19. FLANK
6. RIR	12. RICH FLANK	20. FLANK
7. RIR	13. RICH FLANK	21. ESC

V5F/TOH
THERMOGRAPHY + OZONE + HUMIDITY PROTECTION RELAY

varixx

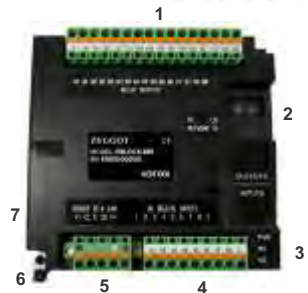

EBLOCK 88R

- 1- DIGITAL DC OUTPUTS
- 2- NETWORK ID SELECTOR SWITCHES
- 3- STATUS LEDs
- 4- DIGITAL DC INPUTS
- 5- CAN and POWER
- 6- EARTH GROUND
- 7- CAN PORT - RJ45

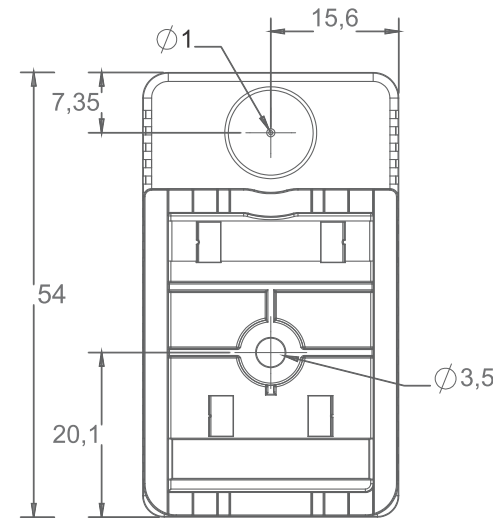

BT SENSOR

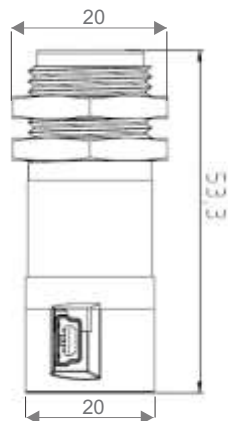
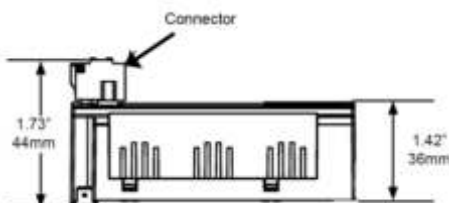
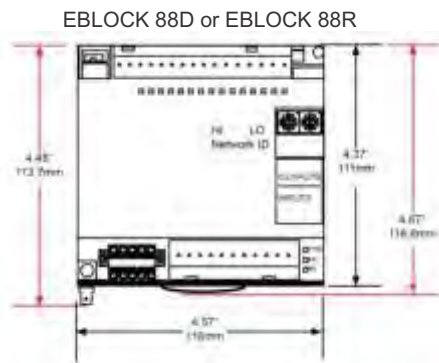

TUBULAR SENSOR

DIP SWITCHES			
PIN	NAME	FUNCTION	DEFAULT
1	RS-485 Termination	ON = Terminated	OFF
2	CAN Termination	ON = Terminated	OFF
3	Bootload	Always Off	OFF

DIP Switches on the relay



CAN Address Keys in Eblock 88x from 1 to 253 (decimal) or 01 to FD (Hexadecimal)

CHARACTERISTICS V5F/TOH RELAY + EBLOCK 88x

Power Supply	24 Vcc, 150 mA
Moisture	5 to 95%
Dimensions Relay	96 mm x 125 mm x 31 mm
Dimensions Eblock	116 mm x 118,6 mm x 44 mm
Connections Relay	1 x RS232 1 x RS485 1 x CAN (125 Kbps - 1 Mbps) 1 x Ethernet (1-10 Mbps/100 Mbps) 1 x USB Mini Program 1 x USB Flash 1 x Micro SD/SDHC
Inputs Relay + Eblock	4 analogue 0-20 mA (50 ohms) 12 Bits, Error: 1,5% FS Max 4 + 8 digital 0-24 VDC Min On= 8VDC. Max Off: 3VDC
Outputs Relay + Eblock	4 + 8 (10 Programmable), Half-Bridge 0.5A max, 10 to 30 VDC, C. Source + Protection: Short and Overvoltage. or 8 Relay 3A @ 250 VAC Resist. Load
Communication Relay	Modbus RTU, CsCAN Ethernet, Devicenet (Optional)
Communication Eblock	CAN
Relay Screen	Color Screen, WVGA (480 x 272) Colors = 64K Resistive Touch Screen 4,3" 450 cd/m ²
Certificates	CE / FCC Compliance - Part 15 of FCC
Connectors	3,5 mm - Pluggable
Weight	Relay: 270 g /// Eblock: 340 g
Temperature	Operation: -10°C to 60°C Stored: -30 °C to 70 °C
Battery RTC Relay	Operation: > 10 Years Stored: 5 to 10 years Clock Error: 8 s / month at 25 °C max

V5F/TOH RELAY:

- Ambient Operating Temperature: 0 to 45°C.
- Storage ambient temperature: -40 to 85°C.
- Relative Humidity: 5 to 95% N.C.
- NEMA Rating: NEMA 4X.
- Relay weight: 270 Grams.
- Dimensions: 125 x 96 x 31 mm.
- Noise immunity (EMC Immunity): EN61000-4-2 / EN61000-4-4 / EN61000-4-5 / EN61000-4-12 / ENV50140/50141
- Emissions: EN50081-2 / EN55022 / CISPR11. Class A.

CAN NETWORK:

- 1: V+
- 2: CAN H
- 3: SHIELD
- 4: CAN L
- 5: V -

CAN POWER RANGE:

12 to 25 VCC / 75 mA MAXIMUM.

CONFIGURATION AND TESTING OF SENSORS

A sensor configuration program, free of charge, once installed on a PC, allows correctly configuring each sensor, before installing them in the panels or even after they are installed. The sensor can be reconfigured many times as necessary. More details in the chapter «Sensor Configuration» later in this manual.

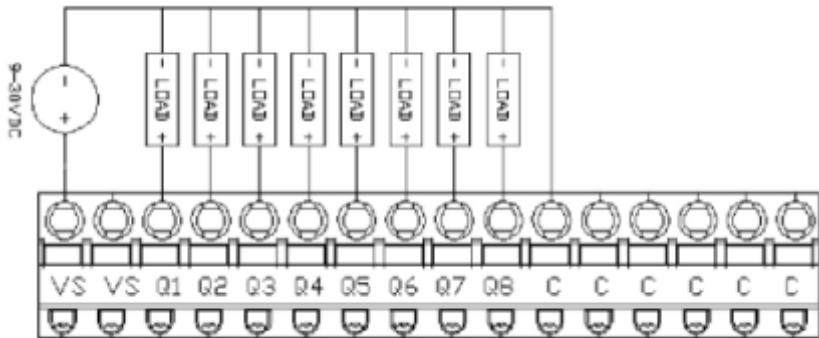

EBLOCK EB/88D OUTPUTS

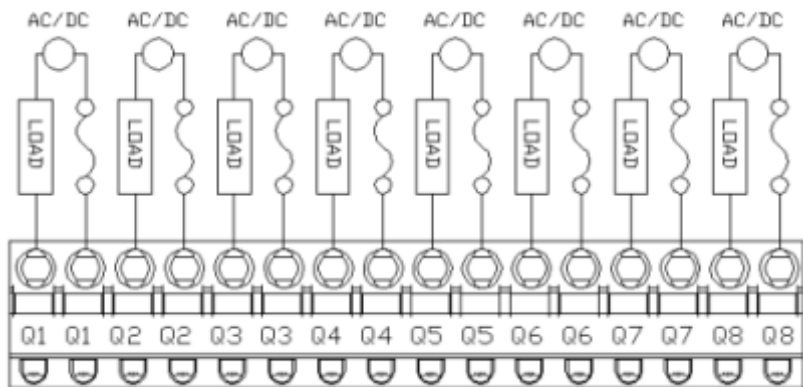

EBLOCK EB/88R OUTPUTS

ONLINE THERMOGRAPHY WITHOUT CONTACT OF ACTIVE PARTS WITH THE BUS. THE TUBULAR SENSOR TYPE IS POSITIONED AT A DISTANCE, BEING INDICATED FOR MEDIUM AND HIGH VOLTAGE AND THE BT SENSOR IS FIXED ON THE BUS, BUT ONLY THE POLYCARBONATE PLASTIC BOX, RESISTANT TO 200 ° C, STAY IN CONTACT. THE MEASUREMENT SENSOR IS NOT IN CONTACT, MEASURING ALSO BY IRRADIATED INFRARED. THE SENSORS ARE POWERED BY THE NETWORK CABLE.

RELAY V5F/TOH TECHNICAL SPECIFICATIONS

POWER SUPPLY

Signal Pin	Description
V+	Input power supply voltage
V-	Input power supply ground
Gnd	Frame Ground

GENERAL CHARACTERISTICS

- ! Graphical LCD Touch Screen w/ Backlight.
- ! 24 VDC
- ! RS-232 / RS-485 Serial Ports.
- ! Integrated Bezel.
- ! Real-Time Clock.
- ! Flash Memory for easy field upgrades.
- ! Ethernet LAN Port.
- ! USB port e Memory Card (to 32GB) available.

CAN or CsCAN (OPT)

Peer-to-peer network. CAN-based network hardware is used in the controllers because of CAN's automatic error detection, ease of configuration, low-cost of design and implementation and ability to operate in harsh environments. Networking abilities are built-in to the control Module and require no external or additional modules.

CAN Network Baudrate vs. Total Cable Length

Network Data Rate Maximum	Total Cable Length
1Mbit / sec.	40m (131 feet)
500Kbit / sec.	100m (328 feet)
250Kbit / sec.	200m (656 feet)
125Kbit / sec.	500m (1,640 feet)

Mj1/ MJ2 PORT MODULAR JACK

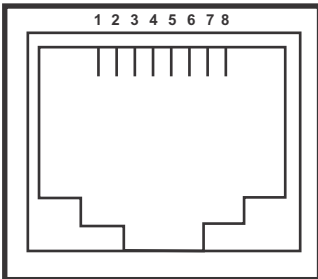

MJ 1 PORT

PIN	SIGNAL
1	-
2	-
3	CTS
4	RTS
5	+5 V
6	0 V
7	RXD
8	TXD
Output Power Supply Max 150 mA	

Characteristics

Display Type (LCD Touch Screen):	64K Color Touch Screen
Display Size:	4,3"
Display Screen:	480 x 272 pixels
Touch Screen Type:	Resistive
Number of Colors:	64K
Power Current:	150mA @ 24VDC
Inrush Current:	(20A @ 24VDC) for 1ms.
Height:	96.0 mm)
Width:	125 mm)
Mounting Depth:	31 mm)
Weight	270 g)
Keypad Material:	Lexan HP92 by GE Plastics.
Protocols supported Serial Ports:	CsCAN, Modbus Master, Modbus Slave, and ASCII
Read and Write CAN Ports:	CsCAN (up to 253 drops)
Serial Ports:	2: RS-232 / RS-485 Ports.
Network Ports:	1: CAN (CsCAN peer)
Temperature & Humidity:	10 - 60°C,
5 to 95% Non-condensing CE	Compliant

CAN PORT PINS

PIN	SIGNAL	DESCRIPTION
1	V-	POWER -
2	CN_L	SIGNAL -
3	NC	NC
4	CN_H	SIGNAL +
5	V+	POWER +

Note: To optimize CAN network reliability in electrically noisy environments, the CAN power supply needs to be isolated (dedicated) from the primary power. The CAN Shield must be attached to the panel as close to the Relay as possible.

MJ 2 PORT

PIN	SIGNAL
1	RX+/TX+
2	RX-/TX-
3	-
4	-
5	+5 V
6	0 V
7	-
8	-
Output Power Supply Max 150 mA	

MAIN SCREENS FOR OPERATION

MAIN MENU, (ESC) INFO SCREENS



MAIN MENU:

Screen from which all other system screens are accessed.

From here, all operating and programming screens are accessed.

Note that, to eventually draw the operator's attention, the «ALARM» field will flash and have a red border to indicate that there is an Acknowledged or Cleared alarm on the Alarm screen. By touching this field, you enter the alarm screen and can acknowledge and reset the alarm.



INFO SCREENS 1 to 5:

There are 5 screens, the one above, and the four below. They are paged through using the >> and << keys and accessed through the ESC key on the main menu.

INFO SCREEN 1: Contains various information. When the system is powered on, this is the initial screen. Pressing ESC takes you to the main menu above.

VERS: Software version

SENSOR COMM. OK: Indicates that the sensor network is communicating OK.

SENSOR COMM. ERROR: Indicates that the sensor network is experiencing a communication failure.

LINK ETHERN.OK: Indicates that the Ethernet connection is OK.

ETHERNET NOT LINKED: Indicates that the Ethernet connection is OK.

DATE, TIME and DAY OF THE WEEK: from the internal real-time clock.

FAIL: Indicates a failure that has not been reset.

TRGT: Indicates a failure related to Target (Targets).

AIR: Indicates a failure related to air (sensor bodies). **OZO:** Indicates a fault related to the ozone level.

H: Indicates a fault related to the relative humidity level in the air.

NR: Indicates the existence of 1 or more sensors not responding in the network.

ALRM: Indicates the alarm condition not silenced (without Mute) and the alarm output active.

TRIP: Indicates a Trip failure condition (Trip output active, not reset).

ATTENTION: THE ZYGGOT V5F/TOH RELAY LEAVES THE FACTORY WITH A PASSWORD TO ENTER THE PROGRAMMING MENU = «827499»
CHANGE IT, WITHIN THE «RELAY CONFIG» MENU TO ANY OTHER VALUE (ADVISABLE).

MAIN SCREENS FOR OPERATION

a- MAIN MENU, (ESC) INFO SCREENS

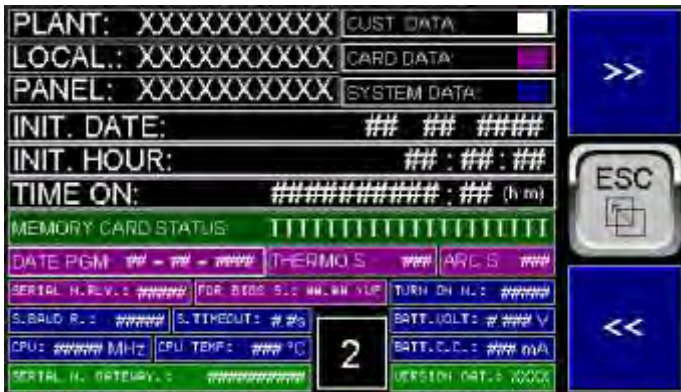

INFO SCREEN 2: It shows information about the plant, location and panel names, date and time of start of operation, total system operation time, relay serial number, software serial number, number of times the relay was turned on, baud rate and timeout of the sensor communication network, number of programmed sensors and finally it also shows some hardware information.

Other fields as in screen 1.



INFO SCREEN 3: Mute Alarm and Reset Fail Buttons.

When the alarm is active, the Mute button silences it (turns off the Alarm Output).

When the alarm is in Mute condition (Mute has already been executed), the Reset button clears the fault and turns off the Trip Output.

Fail Active: Indicates that there is an active fault.

Alarm Unacknowledged: Indicates that there is an alarm that has not yet been acknowledged by the operator on the alarm screen and, depending on what is programmed in the Reset on Fail Unacknowledge parameter, it will not be possible to reset the faults and cancel the trip output.

Alarm Uncleared: Indicates that there is an alarm that has not yet been cleared by the operator on the alarm screen and, depending on what is programmed in the Reset on Fail Active parameter, it will not be possible to reset the faults and cancel the trip output.

Other fields as on screen 1.

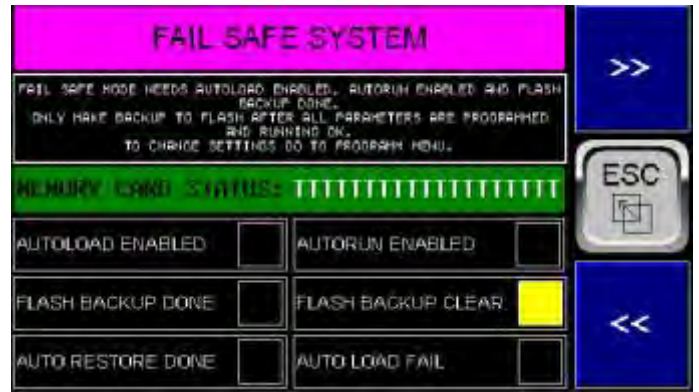

INFO SCREEN 4: «Fail Safe» system information such as Auloload Enabled, Autorun Enabled, Flash Backup Done (these 3 fields must be active, in green for the «Fail Safe» system to operate correctly if necessary. Flash Backup Cleared: It will indicate in yellow if there is no Backup file in the Flash memory. To create the backup file, enter the programming menu and create it after having all the parameters programmed and with the relay operating correctly.

Auto Restore Done, Indicates whether there was an automatic software restoration and Autoload Fail indicates whether there was a restoration failure.



INFO SCREEN 5:

On this screen, you can control the write and read protection on the memory card for safe removal and insertion of the card, with the relay in operation, preventing it from being manipulated during writing operations that could corrupt it.

Remove/Insert: This button is invisible if the relay is in writing or reading operation so that the Remove/Insert command is not entered at an inappropriate time.

Wait: If active, it indicates that the relay is in writing or reading operation.

No Card: It is active if the relay does not have a memory card inserted.

Card OK: Indicates that the card is inserted and operating properly.

Ready to Remove/Insert: After the Remove/Insert command is selected in the «Yes» option, this indication becomes active, indicating that the card can now be removed or inserted.

Memory Card Status: May display one of the following messages depending on the current system condition:

- 1- Card OK - Operational
- 2- Unknow Format
- 3- No card in slot
- 4- Card Not Supported
- 5- Illegal Swapped
- 6- Unknow Error
- 7- Access Protected

After the Insert/Remove command is selected as «Yes», the message will be 6- Access Protected.

Attention: Removing the card without the Insert/Remove command inserts the Alarm condition in the alarm and history screen if the action for this fault is selected as «Log» in the programming menu. If the action is selected as «None», this alarm will not be logged.

If the card is removed after the Insert/Remove command, the alarm will not be triggered even if programmed for «Log»

MAIN SCREENS FOR OPERATION

1a- MAIN SCREEN



MAIN SCREEN MS1 a Ms11:

MS1:
> TARGET: Shows the highest target temperature measured among all sensors.
> AIR: Shows the highest air/sensor body temperature measured among all sensors.
> OZONE: Shows the highest ozone concentration measured among all sensors.
> HUMIDITY: Shows the highest relative humidity level measured among all sensors.

Fail Active: Indicates that there is an active fault.
Alarm Unacknowledged and **Alarm Uncleared:** Indicate that there is an alarm acknowledged (Ack) and not cleared (cleared) respectively, still by the operator on the alarm screen and depending on what is programmed in the Reset on Fail Unack or Reset on fail Active parameters, it will not be possible to reset the faults and cancel the trip output.
AIR W.U. SENSOR and **TRG W.U. SENSOR:** Indicate the current air and target "Warm Up" compensation values for the THM sensors, if this function is used. (Normally not used).
SCAN OK: Indicates each Scan of all THM sensors.

Other indications: as described on INFO SCREEN 01.



MS2: READING THERMO

NEW SCAN: Indicates new sensor reading scans on the network. This is done continuously.
READING SENSOR: Shows the number of the sensor being read and a bar graph corresponding to the number of the sensor currently being read. This serves to show activity and generate confidence that the sensors are being read continuously. It also shows the time remaining for new saving of the target and air temperature data for all sensors if programmed to perform this action. If not programmed, it will always show zero.
TIME TO AUTO SAVE DATA: Shows the time for automatic data saving, depending on the programming in the corresponding parameters.
Other indications: as described on INFO SCREEN 01.



MS3: STATISTIC

PROGRAMMED: Shows the total number of sensors in the network for both THM and ozone sensors and the total.
RESPONDING: Shows the number of sensors responding in the network for each type and the total.
NOT RESPONDING: Shows the number of sensors not responding in the network for each type and the total.
TOTAL ALARMS: Shows the total number of alarms in the system, occurring since the last action to reset this number from the programming menu.
TOTAL TRIPS: Same as number of trips occurred.
Other indications: as described on INFO SCREEN 01.

MAIN SCREENS FOR OPERATION

1b- MAIN SCREEN



MS4:
DIGITAL INP.1 to 4: Indicates the status of the digital inputs of the V5F/TOH relay.
DIGITAL OUT 1 to 4: Indicates the status of the digital outputs of the V5FT/TOH relay.
Digital Input EB1 (Aux 1) to EB8 (Aux 8): Indicates the status of the digital inputs of the EBLOCK module, if used.
Digital Output EB1 (Aux 1) to EB8 (Aux 8): Indicates the status of the digital outputs of the EBLOCK module, if used.
Other indications: as described in the INFO SCREEN 01 screen.

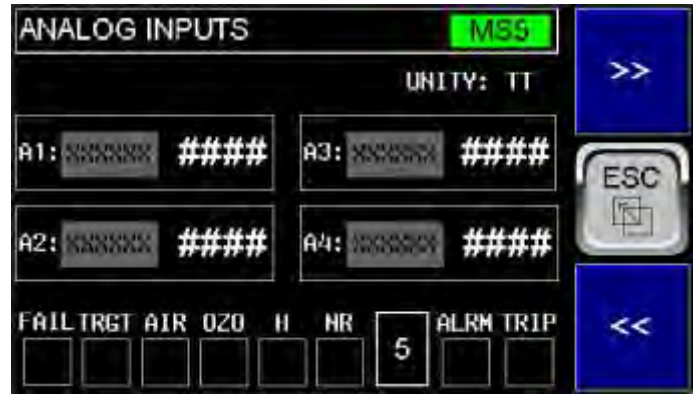

MS5: ANALOG INPUTS
ANALOG INP.1 to 4: Shows the values of Analog inputs 1 to 4 if used. It also shows the name assigned by the user to each input to facilitate identification.
Other indications: as described in INFO SCREEN 01.



MS6: SENSOR COMMUNICATION
SENSOR COMM OK: Indicates whether communication with the sensors is OK.
S. COMM ERROR: Indicates whether there is a communication error with the sensor network.
TIMEOUT: Indicates whether there is a Timeout error with the sensors.
FRAME/PARITY: Indicates whether there is a Frame or Parity error in the network.
RESP FORM: Indicates whether there is an error due to an unexpected response.
ADDR REJECTION: Indicates whether there is an error due to address rejection in the sensor network.
CMM REJECTION: Indicates whether there is an error due to communication rejection in the sensor network.
Other indications: as described in the INFO SCREEN 01 screen

MAIN SCREENS FOR OPERATION

1c- MAIN SCREEN



MS7: MODBUS SERIAL Rs232

MODB ACTIVE: Indicates whether MODBUS is active.
MODBUS INACTIVE: Indicates whether MODBUS is inactive.
MODBUS OK: Indicates whether Modbus is OK, without error.
MODBUS ERROR: Indicates whether there is an error in Modbus.
MODBUS STATUS: (TIMEOUT, VALID MESSAGE, PARITY ERROR, FRAME ERROR, OVERRUN ERROR, CHECKSUM ERROR)
Other indications: as described in INFO SCREEN 01



MS9: ACTIVE FAILS

Active Faults (Not memorized and still in fault condition at the moment)
TARGET ALARM: Indicates if there is any THM target in alarm condition.
TARGET TRIP: Indicates if there is any THM target in Trip condition.
AIR ALARM: Indicates if there is any THM air (body) in alarm condition.
AIR TRIP: Indicates if there is any THM air (body) in Trip condition.
DIFFER. ALARM: Indicates if there is any Target (Temperature) or Ozone Level in differential alarm condition.
SENS. COMM. FAIL: Indicates if there is a communication failure with the sensor network.
MODBUS FAIL: Indicates a communication failure with the external device connected to the relay's Modbus network.
SENS. NOT RESP: Indicates a Not Responding failure in the sensor network.
DIFFER. TRIP: Indicates if there is any target (Temperature) or Ozone Level in differential Trip condition, if programmed to use this condition.
AIR ALARM: Indicates if there is any THM sensor with AIR temperature (Body) higher than the level programmed for Alarm
AIR TRIP: Indicates if there is any THM sensor with AIR temperature
OZONE ALARM: Indicates if there is any ozone sensor with a level higher than the level programmed for Alarm.
OZONE TRIP: Indicates if there is any ozone sensor with a level higher than the level programmed for Trip.
HUMIDITY ALARM: Indicates if there is any ozone+humidity sensor with a level higher than the level programmed for Alarm.
Other indications: as described in INFO SCREEN 01



MS8: ETHERNET COMMUNICATION

LINKED: Indicates that the Ethernet cable is connected.
NOT LINKED: Indicates that the Ethernet cable is disconnected.
HALF DUPLEX and FULL DUPLEX: Indicates the current communication mode.
SPEED 10 Mbps and SPEED 100 Mbps: Indicates the current communication speed.
RX: Indicates that data is being received.
TX: Indicates that data is being transmitted.
Other indications: as described but on the INFO SCREEN 01 screen

MAIN SCREENS FOR OPERATION

1d- MAIN SCREEN



MS10: MUTE / RESET

MUTE ALARM / RESET FAIL: Buttons that allow you to silence (Mute Alarm) the alarm or reset (Reset Fail) the fault condition. Reset Fail will only act if it is already silenced (Mute) and if 'Reset on Fail' is programmed if there is still an existing fault.

Other indications: as described but on INFO SCREEN 01

MEMORY CARD STATUS: Displays one of the sentences, as described in Info Screen 4 above.

BACKUP STATUS: Displays one of the following sentences depending on the current situation:

1- STANDBY / 2- OK - PROCEED / 3- ERROR - CHECK CARD / 4- DONT BACKUP ON FAIL / 5- OK - DONE / 6- WRITING / 7- READING / 8- BUSY.

In the example below, target temperatures, with 10 sensors, 10 responding. The same applies to the **AIRDATA** file.

Other indications: as described but on INFO SCREEN 01

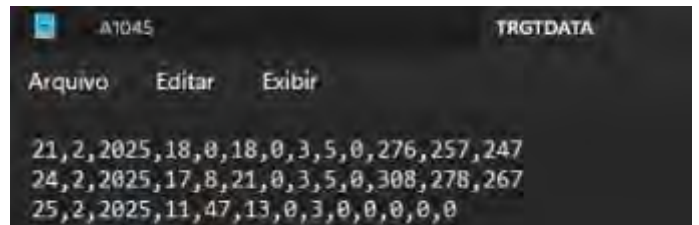
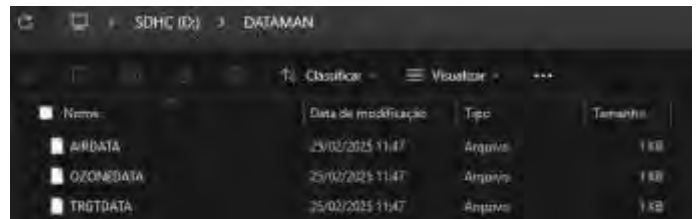

MS11: MANUAL SAVE DATA (THM)

On this screen, you can save the target and air temperature data from all sensors to the memory card, by manual command, at any time.

These files are in Excel CSV format with data separated by commas and can be opened in Excel and generated in tables or graphs.

SAVE TARGET TEMPERATURES: When pressed, it turns green while the target temperature data is added to the corresponding file on the memory card.

This file is located in the **DATAMAN** directory and in the **TRGTDATA** file and the data is added to the existing ones with the following sequence: dd, mm, yyyy, hh, mm, ss, 0, NS, SR, 0, T1, T2, T3,.....Tn. (zero serves as a separator).

SAVE AIR TEMPERATURES: When pressed, it turns green while the air temperature data is added to the corresponding file on the memory card. This file is located in the **DATAMAN** directory and in the **AIRDATA** file and the data is added to the existing data in the following sequence: dd, mm, yyyy, hh, mm, ss, NS, SR, 0, T1, T2, T3,.....Tn. (zero is used as a separator).

SAVE OZONE LEVELS: When pressed, the background turns green while the air temperature data is added to the corresponding file on the memory card.

This file is located in the **DATAMAN** directory and in the **OZDATA** file and the data is added to the existing data in the following sequence: dd, mm, yyyy, hh, mm, ss, NS, SR, 0, T1, T2, T3,.....Tn. (zero is used as a separator).

The above buttons are invisible if the moment is not suitable for saving data, such as another instance of writing or reading the card is in progress.

MAIN SCREENS FOR OPERATION

2-TARGET, 3- AIR, 4- OZONE, 5- HUMIDITY

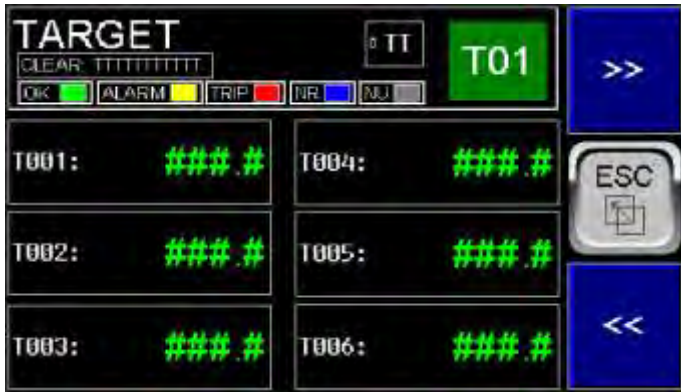

TARGET T01 to T21:

There are 21 screens, scrolled by the >> and << keys.

T01 to T21: Screen Index. Flashes if any of the Target values is above the stipulated alarm value.

°TT: Indicates °C (degrees Centigrade) or °F (degrees Fahrenheit), as programmed.

T001 to T125 (screens 1 to 21): Shows the current temperature of each target. The color will be green if within the normal range, yellow if above the programmed Alarm point and red if above the programmed Trip point. If yellow or red, it will also flash. It will be blue if the respective sensor is not responding and gray for non-programmed sensors.

CLEAR: (After Reset / Auto): Indicates whether the Reset of the fault indication is programmed to clear automatically if the fault does not persist or only after pressing the «Reset» key.



OZONE T01 to T21:

There are 21 screens, scrolled by the >> and << keys.

T01 to T21: Screen Index. Flashes if any of the Target values is above the stipulated alarm value.

TTT: Indicates PPB (Parts per Billion) or % (Percent) as programmed.

L001 to L125 (screens 1 to 21): Shows the ozone level. The color will be green if within the normal range, yellow if above the programmed Alarm point and red if above the programmed Trip point. If yellow or red, it will also flash. It will be blue if the respective sensor is not responding and gray for non-programmed sensors.

CLEAR: (After Reset / Auto): Indicates whether the Reset of the fault indication is programmed to clear automatically if the fault does not persist or only after pressing the «Reset» key.



AIR T01 to T21:

There are 21 screens, scrolled by the >> and << keys.

A01 to A17: Screen Index. Flashes if any of the Air (sensor body) values is above the stipulated alarm value.

°TT: Indicates °C (degrees Centigrade) or °F (degrees Fahrenheit), as programmed.

A001 to A125 (screens 1 to 17): Shows the current temperature of each target. The color will be green if within the normal range, yellow if above the programmed Alarm point and red if above the programmed Trip point. If yellow or red, it will also flash. It will be blue if the respective sensor is not responding and gray for non-programmed sensors.

CLEAR: (After Reset / Auto): Indicates whether the Reset of the fault indication is programmed to clear automatically if the fault does not persist or only after pressing the «Reset» key.



HUMIDITY H01 to H21:

There are 21 screens, scrolled by the >> and << keys.

H01 to H21: Screen Index. Flashes if any of the Target values is above the stipulated alarm value.

TTT: Indicates PPB (Parts per Billion) or % (Percent) as programmed.

H001 to H125 (screens 1 to 21): Shows the relative humidity level. The color will be green if within the normal range, yellow if above the programmed Alarm point and red if above the programmed Trip point. If yellow or red, it will also flash. It will be blue if the respective sensor is not responding and gray for non-programmed sensors.

CLEAR: (After Reset / Auto): Indicates whether the Reset of the fault indication is programmed to clear automatically if the fault does not persist or only after pressing the «Reset» key.

MAIN SCREENS FOR OPERATION

6-FAILS



FAILS AF1 to AF7:

There are 7 screens scrolled by the >> and << keys.

They indicate the memorized faults (active or not at the moment) if selected in the programming menu for LOG, ALARM or TRIP. They are self-explanatory.

The Mute Alarm and Reset Fail buttons on each screen allow you to silence the alarm (digital alarm output) or Reset the fault, respectively. Note that to reset the fault you must first perform the Mute and also that the fault no longer exists if the 'Reset On Fail' parameter is not enabled in the Programming menu.

They also show the conditions: **Alarm State Active** and **Trip State Output**.

Fail Active, Alarm Unacknowledged and **Alarm Uncleared**: as detailed in screen MS1.

MAIN SCREENS FOR OPERATION

7a- DATA PLOT

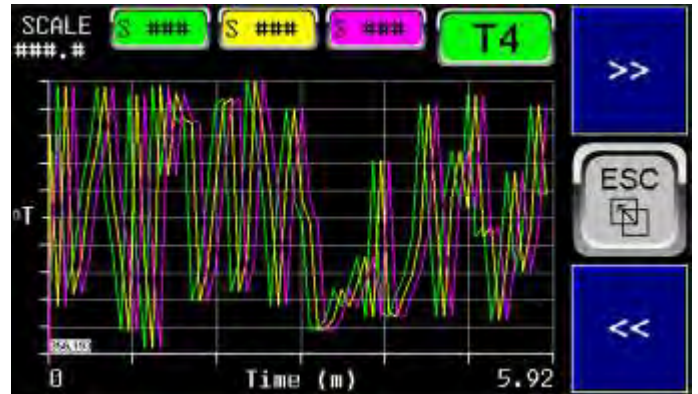
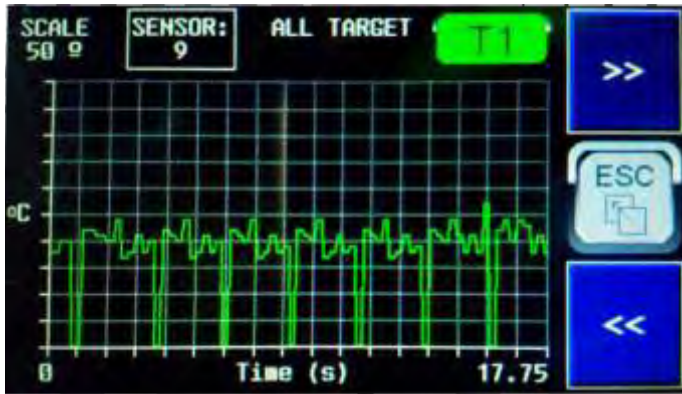

DATA PLOT T4 (Continuous Scope)

This screen shows both temperature and ozone levels, depending on the sensors selected.

T4: Screen Index and curve reset button (plot restart) if programmed to be active in the programming menu.

On this screen, you can enter the indexes of 3 sensors, from 1 to 125, and if you enter «0» (zero), the trace remains at zero. With each scan, the curve goes down to zero and repeats this continuously as if it were an electrocardiogram. The scan never stops and the curve is continually shifted to the left.

The sampling time is 1 second and the total screen scan time is 5.92 minutes. When you leave this screen and return to it, the curves reset, unlike the curves from T5 to T18.

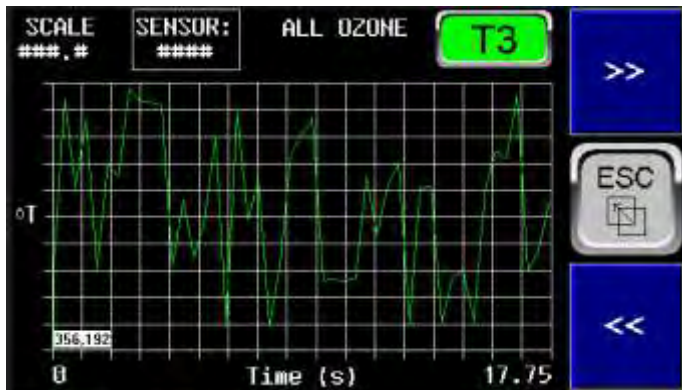
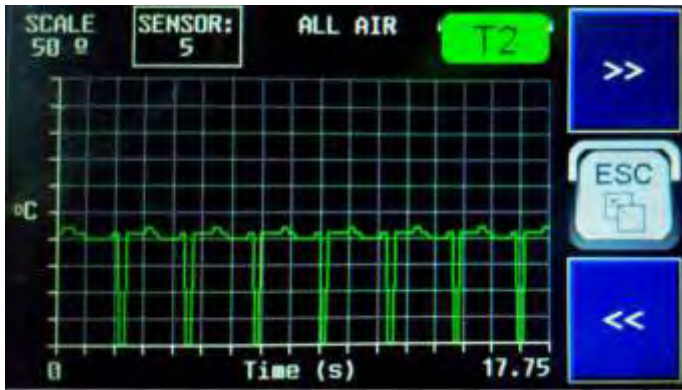

DATA PLOT T1, T2 e T3 (Continuous Scope):

There are 19 screens, scrolled by the >> and << keys. These are the first three.

T1, T2 and T3: Screen Index and curve reset button (Plot restart) if programmed to be active in the programming menu.

The first two show all **Target** and **Air** temperatures respectively, of the THM sensors programmed in the network, sequentially. The third shows the **Ozone** levels of all programmed ozone sensors, sequentially. With each 'scan' of all temperatures, the curve goes down to zero and repeats this continuously as if it were an electrocardiogram. The 'scan' never stops and the curve is continually shifted to the left.

The sampling time is 50 mS and each screen can show 17.75 seconds. When leaving this screen and returning to it, the curves restart, unlike the curves from T4 to T18.

MAIN SCREENS FOR OPERATION

7b- DATA PLOT

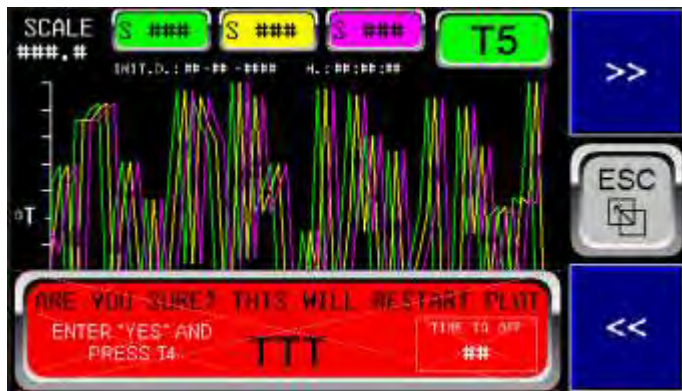
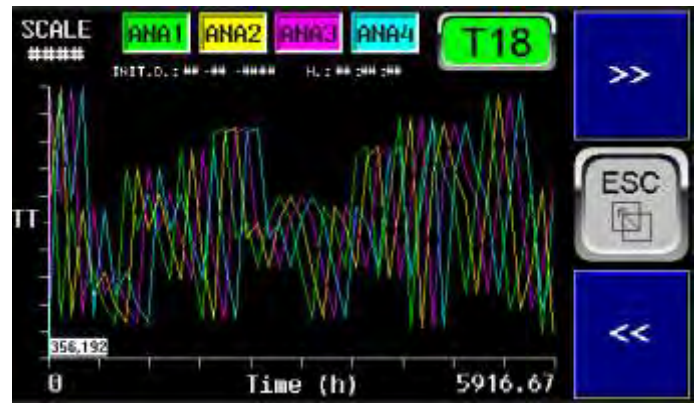
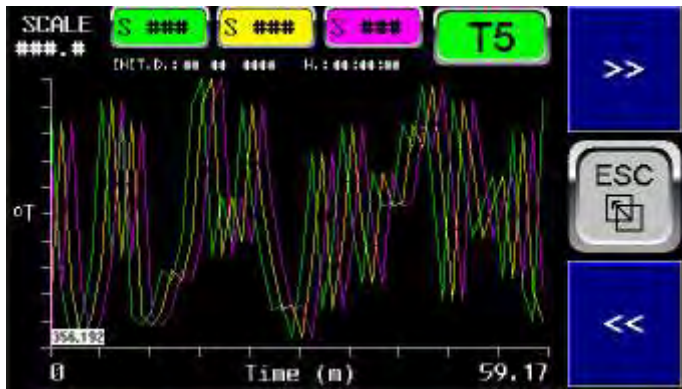

DATA PLOT T5 to T18:

These are screens 5 to 18 of the 19 screens scrolled by the >> and << keys.

T5 to T13: Screen index and curve reset button (Plot restart) if programmed to be active in the programming menu for Temperature or Ozone sensors, depending on the selected sensor.

T14 to T18: Screen index and curve reset button (Plot restart) if programmed to be active in the programming menu for 4 analog inputs. The X axis shows whether the scale is in temperature (°C or °F) or percentage (%). and the scale value is shown in the upper left. The Y axis shows the time scale.

Screens T5 to T13 show 3 sensors each, selected on the screen itself with the S keys (or in the programming menu) and each screen has different reading time bases (See Table). Likewise, screens T14 to T18 show 4 analog input readings each, also with different reading time bases.

These screens from T5 to T18 do not restart the reading automatically when exiting them, they are functional even if they are not displayed and show the curves when voting on them. However, when the screen is finished, the plot does not remain inactive but always shows the memorized traces even if the relay is turned off and on again.

The graph scale is shown in the upper left corner and the date and time of the start of the plot on each of the screens is shown independently of the others.

To restart, touch the buttons T5 to T18.

When pressing the keys T5 to T18, the button appears in red, asking if you are sure you want to restart the curves on this screen. If so, the operator will have 10 seconds to enter the answer «Yes» on the button and touch T5 to T18 again. Otherwise, the red button disappears and the curves are not reset.

If the red button is counting down from 10 seconds and you leave the screen, it is automatically extinguished and the curves are not reset.

Screen	Sampling time	Screen cycle
1 a 3	50 ms	17,75 s
4 e 9	1000 ms	5,92 m
5 e 10	10 s	59,17 m
6 e 11	100 s	591,67 m
7 e 12	1000 s	5916,67 m
8 e 13	1000 m	5916,67 h
14	50 ms	17,75 s
15	1 s	355 s
16	10 s	59,17 m
17	100 m	591,67 h
18	1000 m	5916,67 h
19	10 s	59,17 m

MAIN SCREENS FOR OPERATION

7c- DATA PLOT



DATA PLOT T19 (Retentive Data Plot):

This is screen 19 and the last screen paged by the >> and << keys. This feature allows the recording of the curves and data plotted on it on the memory card of up to 32 Gb inserted in the appropriate slot in the relay, in addition to showing the current curve being recorded and the curves previously memorized on the card.

When initialized in the programming menu, the screen will display in the lower left corner the information in green letters "STARTED" and a file folder will be automatically created on the card with the name **Plotzxx**, where xx is the end of the current year. If it is not started, the message will be "STANDBY".

When in "Started", a new file with the extension csv will be created every hour, within this file, with the name consisting of the day, month and full hour, without the minutes. Each file contains data separated by commas, which can be opened in Excel using the "Get data" function in the "Data" tab and graphs can be generated. Each file is saved automatically every hour and will contain 360 readings of each of the 4 variables (4 traces). Each reading is taken every 10 seconds. They are light files of approximately 18 Kb each. In the graph currently on the screen, even if you exit the screen, the recordings continue and if the recording is interrupted by turning the power off and on again, a vertical black line appears at this point and the recording continues.

On the screen, you can directly enter the variables to be plotted and recorded, one on each upper button with the colors corresponding to the trace. You can enter from 1 to 125, corresponding to targets from 1 to 125 sensors or Ozone levels from 1 to 125 sensors also depending on the selected sensors or from 126 to 129 corresponding to analog inputs 1 to 4 (126 = A1, 127 = A2, 128 = A3 and 129 = A4). If you enter 0 «zero» the trace will remain zeroed at all times.

The two scales are shown in the upper left corner, for target temperatures of the sensors or ozone in green and analog inputs in blue.

On the vertical Y axis, the two corresponding units are shown, with °C in green for the sensors and % or ° for the analog inputs, depending on what is programmed in the programming menu for them.

MAIN SCREENS FOR OPERATION

7d- DATA PLOT

The top left corner shows the two scales, for sensor target temperatures in green and analog inputs in blue.

The two corresponding units are shown on the vertical Y axis, with °C in green for sensors and % or ° for analog inputs, depending on what is programmed in the programming menu for them.

The screen index (T19) is located in the top right corner. This button does not allow for resetting or restarting the curve and, if pressed, indicates with a sentence to enter the programming menu, turn this feature off and on again to restart the curves. This is done for safety reasons so that the memorization is not inadvertently lost.

The recorded curves can also be redone on the screen by the relay itself, for examination. While they are being re-displayed, the user can move their finger on the screen and move the cursor (a vertical black line). Then, for each point, the index of each line and the corresponding value are displayed, with the corresponding colors corresponding to the lines, in addition to the date and time of recording.



At the bottom are the playback control keys. namely.

«Pause» or «Play» If it is showing «Pause», the operation is effectively in Play and the curves are being generated and plotted in real time. When pressed, it changes to «Play» and the operation is effectively in Pause and the curves shown are previously recorded, obtained from the memory card. In other words, the button actually shows the state that will be entered when pressed.

«<<» This button allows you to search for the first recorded curve of the file within the date and time range selected in the Open button.

«>>» Same as above. This button allows you to search for the last recorded curve of the file.

«<» and «>» same as above, allow you to search one by one in the sequence for the sequential recorded curves. «Open» button that allows you to select a time interval for the curves to be retrieved, by date and time, by entering the start date and time and end date and time of the period of interest in the window that opens, to restrict the number of curves to be paged through using the search keys above and to make their location easier.

Below we see an example of the structure of Plot files on the card.

Nome	Data de modificação	Tipo	Tamanho
022113	31/02/2025 13:59	Arquivo de Valores Separados por Vírgulas do Microsoft Excel	17 KB
022116	31/02/2025 16:59	Arquivo de Valores Separados por Vírgulas do Microsoft Excel	17 KB
022117	29/02/2025 17:59	Arquivo de Valores Separados por Vírgulas do Microsoft Excel	13 KB
022118	31/02/2025 18:07	Arquivo de Valores Separados por Vírgulas do Microsoft Excel	1 KB
022256	32/02/2025 08:59	Arquivo de Valores Separados por Vírgulas do Microsoft Excel	17 KB
022267	32/02/2025 07:59	Arquivo de Valores Separados por Vírgulas do Microsoft Excel	18 KB

	A	B	C
1	Date,Time,Pen1,Pen2,Pen3,Pen4		
2	26-02-2025,08:00:07 AM,000030,000026,000000,000000		
3	26-02-2025,08:00:17 AM,000030,000025,000000,000000		
4	26-02-2025,08:00:27 AM,000030,000025,000000,000000		
5	26-02-2025,08:00:37 AM,000030,000025,000000,000000		
6	26-02-2025,08:00:47 AM,000030,000025,000000,000000		
7	26-02-2025,08:00:57 AM,000030,000025,000000,000000		

MAIN SCREENS FOR OPERATION

15- STATUS

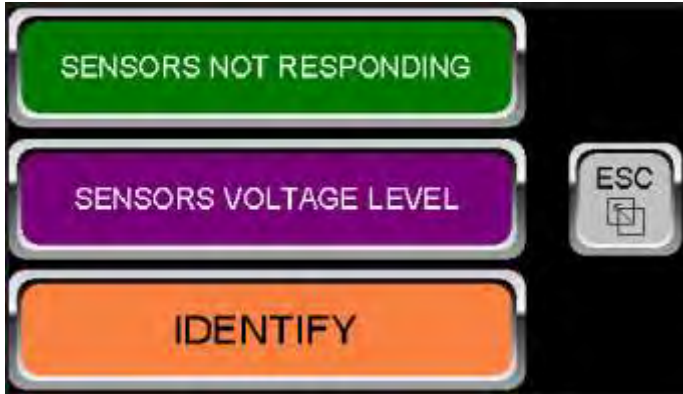

SENSORS NOT RESPONDING, SENSORS VOLTAGE LEVEL, IDENTIFY SENSORS (FLASH).

When you press the «STATUS» key on the main menu, the screen on the left is shown with 3 options.

«Sensors Not Responding» where you can see a square flag for each sensor, which is filled in white if the corresponding sensor is not responding to the network. More details later.

«Sensors Voltage Levels» where you will see the voltage reaching each sensor via the network with a resolution of two decimal places, that is, 0.01 Volts DC. On this screen, the voltages are displayed in 4 different colors depending on the programmed ranges, namely: «Green» if the voltage is within the optimum range (Good), «Yellow» if the voltage is within the acceptable range (Acceptable) in which it is still possible to operate safely, «Red» if the voltage is in the marginal voltage range (Marginal) in which the sensor is still operating but attention must be paid to the length of the network cables and possible power supply from the network at both ends to minimize this factor and «Violet» (NR) if the respective sensor is not responding and in this case the indicated voltage will be 0.00. More details later.

«Identify» where you can control the change of the pattern between continuous lighting and flashing of the LED on the back of each sensor to facilitate its identification on the network and also to check communication with it.

In the current system configuration, each sensor has a LED on the back that flashes continuously, while it is active and communicating with the relay. More details later.

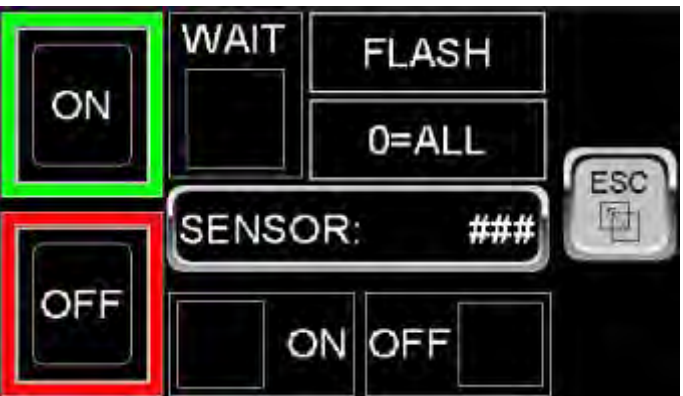

MAIN SCREENS FOR OPERATION

8-TARGET ALRM, 9- TARGET TRIP, 10- AIR ALARM, 11- AIR TRIP.

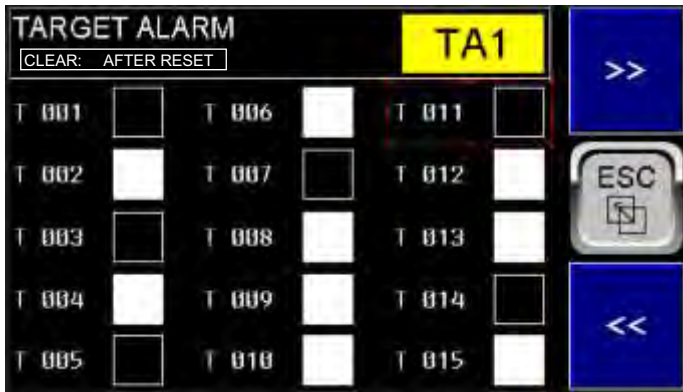

TARGET ALARM TA1 to Ta9:

There are 9 screens, scrolled by the >> and << keys.
Ta1 to TA9: Screen Index. Flashes if any of the Target values is above the programmed alarm value.
T001 to T125 (from screens TA1 to TA9): Indicates whether the temperature of each Target is above the programmed alarm value.



TARGET TRIP TT1 to Tt7:

There are 9 screens, scrolled by the >> and << keys.
Tt1 to TT9: Screen Index. Flashes if any of the Target values is above the value programmed for Trip.
T001 to T125 (from screens TA1 to TA9): Indicates whether the temperature of each Target is above the value programmed for Trip.

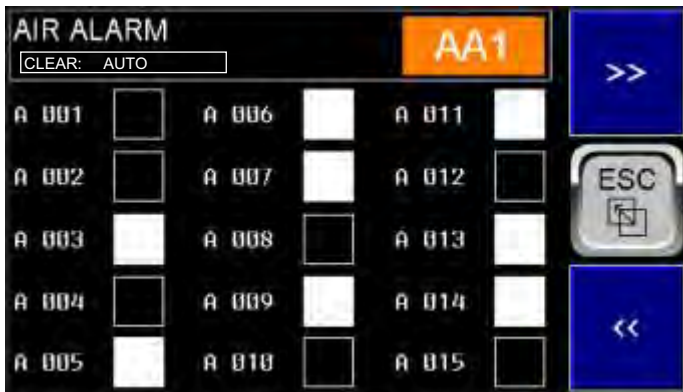

AIR ALARM AA1 to AA7:

There are 9 screens scrolled by the >> and << keys.
AA1 to AA9: Screen Index. Flashes if any of the Air (Body) values is above the programmed alarm value.
A001 to A125 (from screens AA1 to AA9): Indicates whether the temperature of each Air (Body) is above the programmed alarm value.

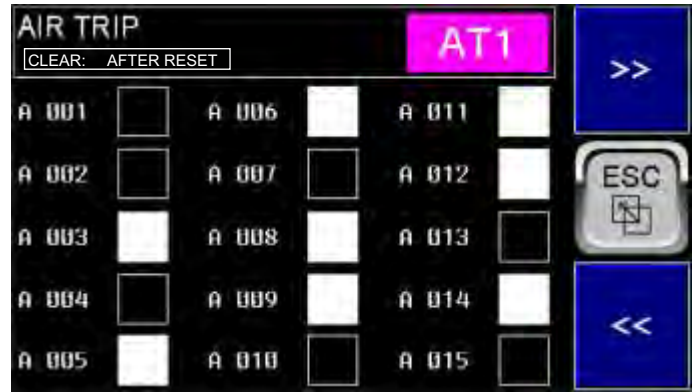

AIR TRIP AT1 a AT9:

There are 9 screens scrolled by the >> and << keys.
At1 to AT9: Screen Index. Flashes if any of the Air (Body) values is above the value programmed for Trip.
A001 to A125 (from screens AT1 to AT9): Indicates whether the temperature of each Air (Body) is above the value programmed for Trip.

MAIN SCREENS FOR OPERATION

12- OZONE ALARM, 13- OZONE TRIP, 14- HUMIDITY ALARM



OZONE ALARM OZA1 to OZA9:

There are 9 screens, scrolled by the >> and << keys.

OZA1 to OZA9: Screen Index. Flashes if any of the ozone level values is above the value programmed for the alarm.

O001 to O125 (from screens OZA1 to OZA9): Indicates whether the ozone level read by each sensor is above the value programmed for the alarm.



OZONE TRIP OZT1 to OZT9:

There are 9 screens, scrolled by the >> and << keys.

OZT1 to OZT9: Screen Index. Flashes if any of the ozone level values is above the value programmed for tripping.

O001 to O125 (from screens OZT1 to OZT9): Indicates whether the ozone level read by each sensor is above the value programmed for tripping.



HUMIDITY ALARM HA1 to Ha9:

There are 9 screens scrolled by the >> and << keys.

Ha1 to HA9: Screen Index. Flashes if any of the relative humidity levels is above the value programmed for the alarm.

H001 to H125 (from screens HA1 to Ha9): Indicates whether the humidity level read by each sensor is above the value programmed for the alarm.

MAIN SCREENS FOR OPERATION

15- THM STATUS



NOT RESPONDING NR1 to NR9:

There are 9 screens that are scrolled by the >> and << keys. **S001 to S125** (from screens **NR1 to NR9**): Indicates whether the respective **THM** or **Ozone** sensor has stopped responding to the relay on the network. The indication only occurs after 2, 3 or 4 scans of all sensors, so that a reliable indication is obtained. Note that the correct indication may take some time depending on the number of sensors on the network and the number of scans. Sensors that are responding correctly are indicated in **BLACK** and if a sensor does not respond, its indication will be in **VIOLET** on the network.

NOTE: Once the system is correctly configured and operating, the possibility of a sensor not responding is extremely remote. This is evidenced by thousands of systems operating worldwide with zero reported sensor failures.

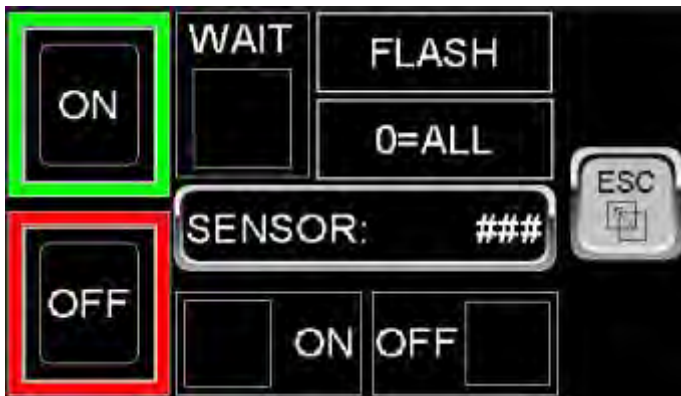

IDENTIFY:

When the ON action is commanded, a THM or Ozone sensor stops flashing. In addition to testing the integrity of the sensor when responding to a command on the network, this also serves to physically differentiate sensors. When the OFF action is commanded, it returns to the normal state, flashing continuously. This command can be executed with the system operating normally. Each sensor on the network has an address from 1 to 125 for THM or Ozone, depending on the programming of the sensor number.

ON: Button to turn on the «Ident» (ON).
OFF: Button to turn off the «Ident» (OFF).
SENSOR: Button where you can enter the sensor number from 1 to 125. If 0 is entered, all sensors on the network will execute the «Ident» command (used to check whether all sensors responded and recognized the command, and are therefore intact).
ON: Indicates that one or all sensors have the «Ident» command active.
OFF: Indicates that no sensor has the «Ident» command active.
 If you try to exit the screen with the «Ident» command active, a «Warning» screen appears for 2 seconds to prevent you from forgetting to turn off the command before exiting the screen.



THM SENSORS VOLTAGE LEVEL TV01 to TV05:

There are 4 screens that are scrolled by the >> and << keys. **V001 to V125** (from screens **TV01 to Tv05**): Shows the supply voltage reaching each sensor via the communication network with shielded sleeved cables and mini USB connectors. Note that there are 3 factory-set voltage levels, which are shown in 3 different colors: **Green** if it is within the optimal range (Nominal is 24 VDC, but much lower voltages are allowed), **Yellow** if it is within an acceptable range in which stable operation is safe, or **Red** if the voltage is below a safe level for operation.

«Sensors Voltage Levels» will show the voltage reaching each sensor via the network with a resolution of two decimal places, that is, 0.01 Volts DC. On this screen, the voltages are shown in 4 different colors depending on the programmed ranges, namely: «**Green**» if the voltage is within the optimal range (**Good**), «**Yellow**» if the voltage is within the acceptable range (**Acceptable**) in which it is still possible to operate safely, «**Red**» if the voltage is in the marginal voltage range (**Marginal**) where the sensor still operates but attention must be paid to the lengths of the network cables and possible power supply from the network at both ends to minimize this factor and «**Violet**» (**NR**) if the respective sensor is not responding and in this case the indicated voltage will be 0.00

Note that as the communication network can have different lengths, depending on the cabling used by each user, the sensors further away from the V5CON device (Interface) and therefore from the power supply may have a greater voltage drop in the wiring. In this case, the user simply needs to divide the network into more than one branch, since this is possible because the sensors are in parallel and as many branches as necessary can be used for better distribution in the cubicles of each MCC or Switchgear, using the accessory device code **ZTA**. It is also possible to supply power from both ends of the network. See wiring suggestions in the chapter «**Typical Interconnections**» earlier in this manual.

In this way, by observing the voltage at each sensor, the user can be sure that the network is operating under safe conditions and it also serves to demonstrate that the sensor is communicating correctly, since it transmits voltages in the same way that it transmits temperature, ozone or humidity information.

MAIN SCREENS FOR OPERATION

16-DIFFERENTIAL

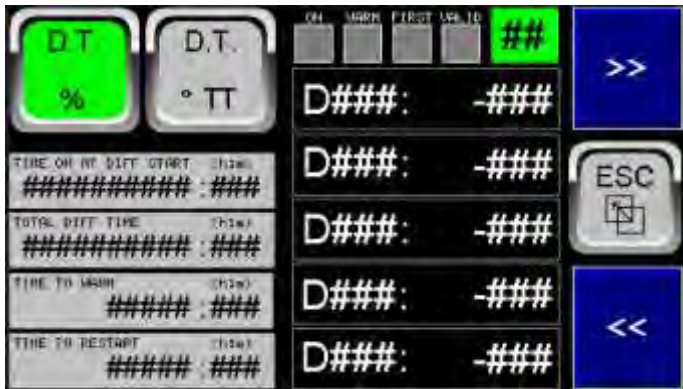

DIFFERENTIAL 1 to 25:

There are 25 screens that are paged by the >> and << keys.

When activated, the sensor indexes are paged 5 by 5 from D1 to D125 and the other fields remain on the screen.

(1) to ## (7): Screen index.

DT%: Button that selects to show the values as a percentage of variation in the programmed time. When selected, it changes from gray to green.

TEMP (°TT): Button that selects the option to show the values as a differential of temperature variation in the programmed time. When selected, it changes from gray to green. °TT shows whether it is in Celsius or Fahrenheit.

ON: Indicator that the system has started the differential function (if programmed for this in the programming menu).

WARM: Indicates that the programmed heating period has passed, during which the system ignores the readings for calculating the differential variation, waiting for the system to stabilize in a normal operating temperature condition.

FIRST: Indicates that the first reading was performed after the 'Warm' period, on which the differential variations will be calculated for each new reading.

VALID: Indicates that the new reading is valid for differential calculations.

TIME ON AT DIFF. START: Shows for information purposes the 'On' time in hours and minutes since the system was started, as per screen 2 of the information screens.

TOTAL DIFF. TIME: Shows the total time since the first valid reading was performed and on which the differential is calculated.

TIME TO WARM: Shows a retroactive counter to zero of the remaining time to complete the 'Warm' period as programmed.

TIME TO RESTART: (only appears if set to 'Valid') Shows a retroactive counter to zero of the remaining time in hours and minutes, for automatic restart of a new differential period, if programmed for this in the programming menu. If not programmed for automatic restart, the system remains indefinitely considering the first reading performed after Warm. If restarted, manually or automatically, and the system is already in stable condition (after Warm), no new Warm period is expected and a new initial reading is performed for future differential calculations. Until the differential calculation begins, after Warm, this field is displayed as 0:0

D### to D###: Sensor indexes from 1 to 100 if the system is operating with an active and valid differential; otherwise, D0 is displayed in all 5 fields.

###: Differential value in % or temperature (°C or °F) or ozone (ppb) for each index from D1 to D125, according to the selection in the % or Temp. selection buttons described above. This value is white if it is below the differential value programmed for alarm, yellow if it is above the differential level programmed for alarm, or red if it is above the differential level programmed for Trip. In both cases, it also flashes and changes color.

MAIN SCREENS FOR OPERATION

19a- PROGRAMM REPORT.

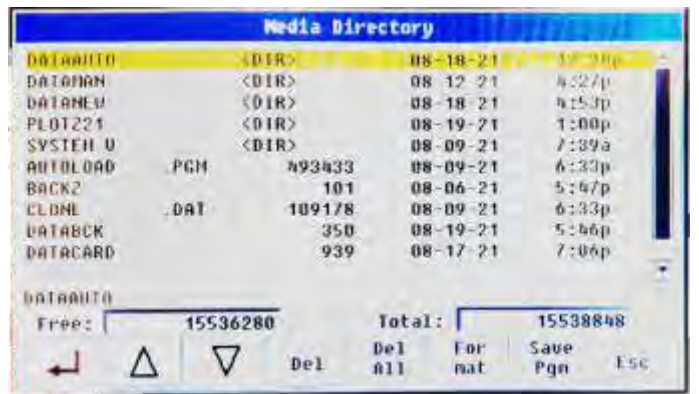
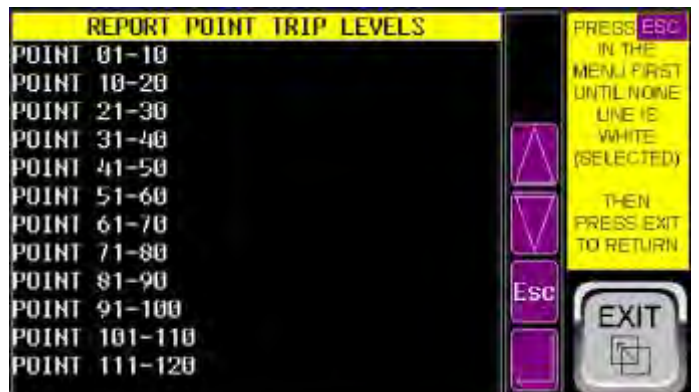
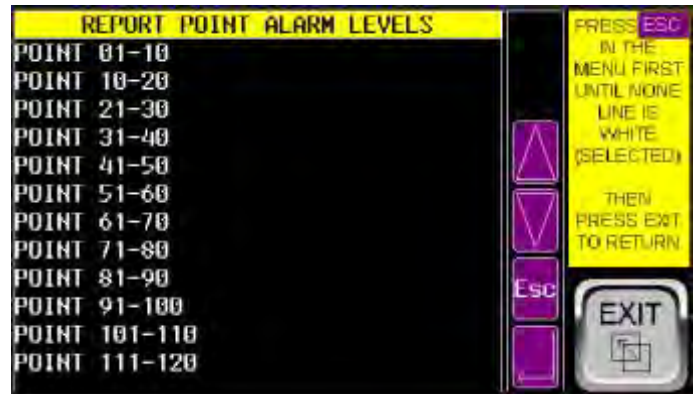
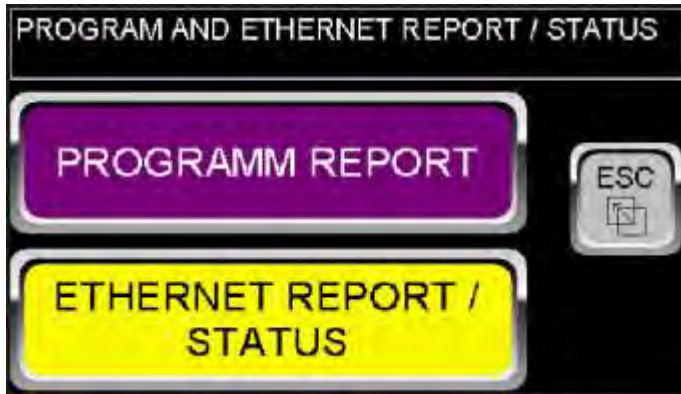

REPORT SCREEN 1 to 5:

There are 5 screens that reproduce the Programming Menu and two more screens with system information, where you can check the various programming conditions without accidentally changing the programming. Note that the two system screens do not allow any data changes since they are only for viewing existing files and not for programming. The screen that shows the directories, although it presents change commands, will not work for security reasons. The user can, however, open the files on the computer and read and change them, but should refrain from changing the files in the root as this may compromise the operation. The files within the directories can be freely changed or deleted without risk. See details of the following parameters in the Programming Menu screens.

MAIN SCREENS FOR OPERATION

19b- ETHERNET REPORT

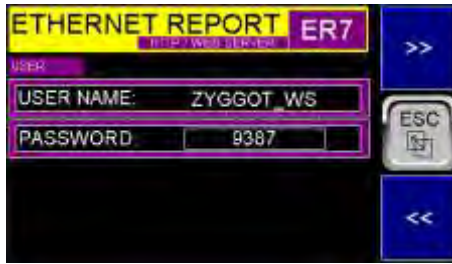
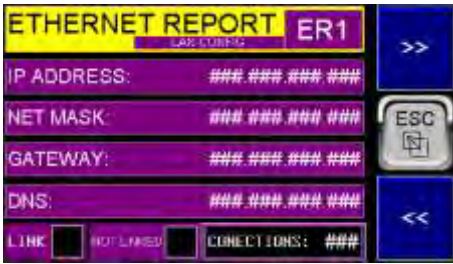

ETHERNET REPORT SCREEN 1 to 9:

There are 9 screens that reproduce the Ethernet Programming Menu, where you can check the various programming conditions without being able to change the programming inadvertently. None of the screens allows commands or changes, with the exception of screen ER3, where you can choose an address and command a PING action to check if a certain device on the network is responding.

The fields on all these screens will be detailed later. Here we will only comment on the function of each one.

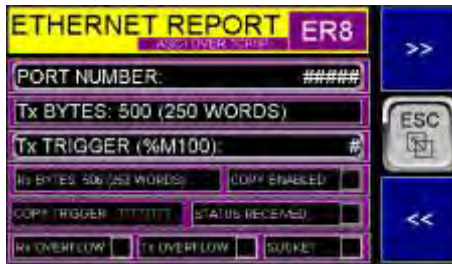
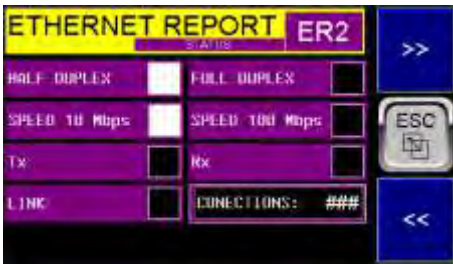

Screens ER1 and ER2 refer to the main Ethernet configuration parameters. Screen ER1 shows the connection status and screen ER2 shows the connection status.

Screen ER3 refers to the ICMP - Internet Control Message Protocol protocol and it is possible to PING the address of a certain device. Screen ER4 refers to the TCP/IP - Transmission Control Protocol (Modbus TCP Server or Modbus Slave). Through this protocol, Modbus Over Ethernet communication can be performed, using all the parameters and addresses described in the Modbus Map at the end of this manual.



Screen ER4 refers to the TCP/IP - Transmission Control Protocol (Modbus TCP Server or Modbus Slave). This protocol allows Modbus Over Ethernet communication, using all the parameters and addresses described in the Modbus Map at the end of this manual.



Screen ER4 refers to the TCP/IP - Transmission Control Protocol (Modbus TCP Server or Modbus Slave). The ER5 screen refers to the IP protocol - Internet Protocol (Ethernet IP Server).

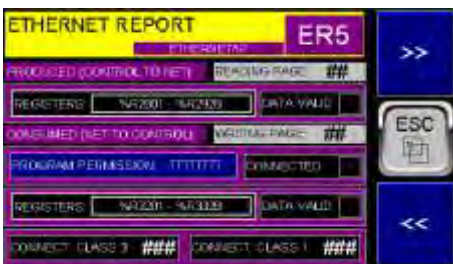

The ER6 screen refers to the FTP protocol - File Transfer Protocol. Through which you can read and access the files on the memory card inserted in the respective slot of the relay and where the temperature readings etc. are recorded using a browser.

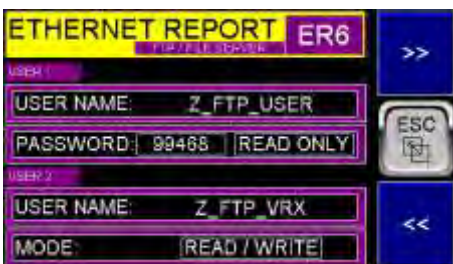

The ER7 screen refers to the HTTP protocol - Hypertext Transfer Protocol.

The ER8 screen refers to the ASCII Over TCP/IP protocol - ASCII Transmission Control Protocol.

The ER9 screen refers to the NTP protocol - Network Time Protocol through which you can obtain precise times from predefined NTP servers.

MAIN SCREENS FOR OPERATION

17- ALARM, 18- HISTORY

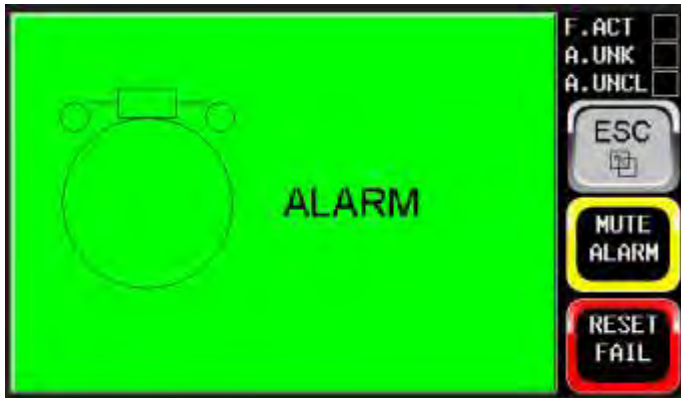

ALARM SCREEN:

ALARM: This is a screen where you can check all Alarms, Faults and events that have occurred, with date and time (Time Stamp), in addition to being able to acknowledge them (Acknowledge) or (ACK) or clear them (Clear). To do this, touch any point on the Alarm screen that is green in the normal condition or red in the condition of activated and unacknowledged (ACK) or cleared (CLR) faults or yellow if there are faults with ACK but not Clear.

F.ACT: Indicates that there is an active fault that has not been reset.

A.UNK: Indicates that there is an unrecognized fault (Unacknowledged).

A.UNCL: Indicates that there is a fault that has not been returned or cleared (Uncleared).

MUTE: Alarm mute button. Turns off the alarm output.

RESET: Fault reset and tripping shutdown button. Only works after Mute.



HISTORY SCREEN:

HISTORY: This is a screen where you can check all the events that have occurred, with date and time (Time Stamp), but you cannot acknowledge or clear them. For this, there is another screen, accessed from within the programming menu. Tap anywhere on the History screen.

The events stored include the Ack and Clear actions performed on the Alarm Screen above, as well as the deactivation of the fault that occurred (Return).

The other fields are the same as those on the Alarm screen above.

PROGRAMMING MENU

20- MENU



In the MAIN "Programming Menu" there are 13 Sub-items or Submenus available, namely:

- M01: Relay Config.
- M02: Parameters Cfg.
- M03: Sensors.
- M04: Block Programming.
- M05: Analog Inputs.
- M06: Modbus Cfg.
- M07: Protections.
- M08: TargetAlarm Levels.
- M09: Target Trip Levels.
- M10: Plot Data Config.
- M11: Clear Data
- M12: Backup/Restore Data
- M13: Ethernet

Sub-item 4 is subdivided as follows:

- M04: Block 1
- M04: Block 2
- M04: Block 1
- M04: Block 2
- M04: Do Block Programm

And sub-item 7 is subdivided into two others, namely:

- M07: Protections 1/2
- M07: Protections 2/2

And sub-item 8 is subdivided into 13

- M8: Target 01-10 a M8: Target 10-125

And sub-item 9 is subdivided into 13

- M09: Target 01-10 a M09: Target 100 -125

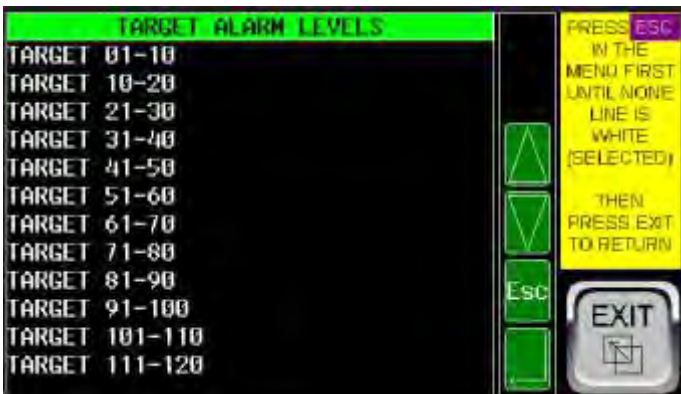

PROGRAMMING MENU

20- MENU

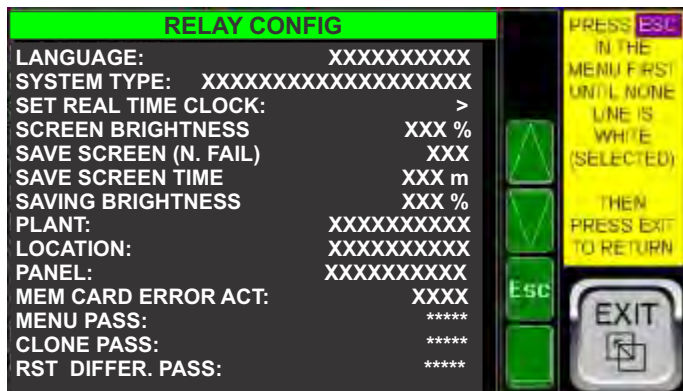

M01-RELAY CONFIG

- 01.1- Language:** (English, Portuguese, Spanish).
- 01.2- System Type:** (Thermo Only, Arc Flash Only, Thermo + Arc Flash). Select one of the operating modes.
- 01.3- Set Real Time Clock:** Enter the correct date and time, if necessary.
- 01.4- Screen Brightness:** Adjust the screen brightness between 50 and 100% for normal operating conditions.
- 01.5- Save Screen (N. Fail):** Select Yes to start reducing the screen brightness after the time programmed below. No to not perform this action. This action will not be performed if it is in failure. (N. Fail) and if it is in screen saving mode and a failure occurs, the screen will return to its normal brightness until the failures are reset.
- 01.6- Save Screen Time:** Adjust the screen inactivity time so that it has reduced brightness. When the screen is touched, the brightness returns to normal and this time starts counting again.
- 01.7- Saving Brightness:** Adjust the screen brightness between 0 and 50% for the screen saving condition.
- 01.8- Plant:** Enter the description of the Plant with a maximum of 10 letters.
- 01.9- Location:** Enter the description of the installation location with a maximum of 10 letters.
- 01.10- Panel:** Enter the description of the panel with a maximum of 10 letters.
- 01.11- Mem Card Error Act:** (None, Log). Select the options None if you do not want the card error alarm to occur or Log if you want the failure to occur.
- 01.12- Menu Pass:** Enter the new Password if necessary, with a maximum of 5 numbers. If set to zero, the programming menu can be accessed by the operator without a password, which entails a risk and is not advisable.
- 01.13- Clone Pass:** Enter the new Password if necessary, with a maximum of 5 numbers to access the Relay Clone menu.
- 01.14- RST Differ. Pass:** Enter the new Password if necessary, with a maximum of 5 numbers to access the Restart Differential Data menu. This request is made to the operator each time the relay is turned on again with active differential data. A new differential cycle can be started from this moment or the initial readings of the differential system valid at the time can be maintained.

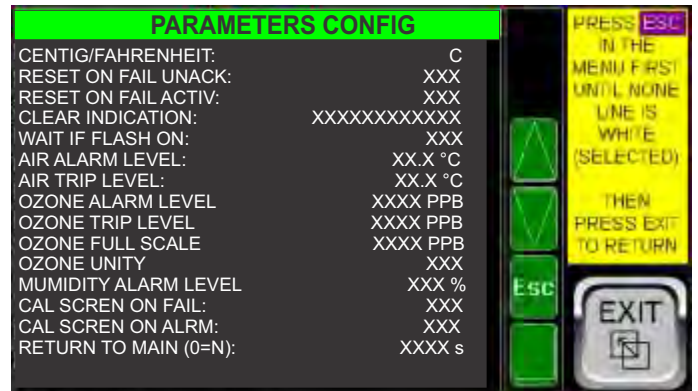

M02-PARAMETERS CFG

- 02.1- Centigrade / Fahrenheit:** (C or F). Choose the Temperature unit.
- 02.2- Reset On Fail Unacknowledged:** (Yes, No). Choose Yes to allow Reset with an unacknowledged failure (Ack). The failure is acknowledged on the Alarm screen. It flashes if there is a non-Ack alarm.
- 02.3- Reset On Fail Uncleared:** (Yes, No). Choose Yes to allow Reset with an unacknowledged failure cleared or reset (Clr). The failure is reset on the Alarm screen. It flashes if there is a non-Clr alarm.
- 02.4- Clear Indication:** (Auto, After Reset). If «Auto» is chosen, the yellow and red indications on the main temperature screens return to white if the temperature returns to a value below the alarm or trip point, but the squares indicating Alarm or Trip remain on until the «Reset» key is pressed. If «After Reset» is selected, the yellow and red colors continue to indicate that an alarm or trip has occurred even if the temperatures have returned to normal, and the indicator squares remain active. The colors and fault indicators only return to normal after «Reset» is activated. This is the factory condition and is the safest, to indicate faults that have already returned to normal conditions.
- 02.5- Wait if Flash On:** (Yes, No). Condition to return to the main screen automatically, as explained in the «Return to Main» parameter below. If «Yes» is selected, it does not automatically return to the main screen if Flash is On.
- 02.6- Air Alarm Level:** Alarm level for air or sensor body. Valid for all sensors.
- 02.7- Air Trip Level:** Trip level for air or sensor body. Valid for all sensors.
- 02.8- Ozone Alarm Level:** Alarm level for ozone level. Valid for all sensors.
- 02.9- Ozone Trip Level:** Trip level for ozone level. Valid for all sensors.
- 02.10- Ozone Full Scale:** Scale for percentage calculation (Full Scale) for indicating ozone levels on the screen in % instead of PPB. For example: if 1000 PPB is entered here and the reading is 500 PPB, the indication on the screen will be 50%. (Note: the sensor's native scale is 2000 PPB).
- 02.11- Ozone Unity:** Here you must choose between PPB and % to show on the screens related to the ozone level.
- 02.12- Humidity Alarm Level:** Alarm level for relative humidity level. Valid for all sensors.
- 02.13- Cal Screen On Fail:** (Yes, No). If set to «Yes», in case of a failure with Trip, the alarm screen will be automatically shown.
- 02.14- Cal Screen On Alarm:** (Yes, No). If set to «Yes», the alarm screen will be automatically displayed in the event of an Alarm.
- 02.15- Return to Main:** Time in seconds after which the relay will automatically display the main screen 1. If set to zero, there will be no automatic return. There will also be no automatic return if you are in the programming menu screens or with «Ident» activated.

PROGRAMMING MENU

20- MENU

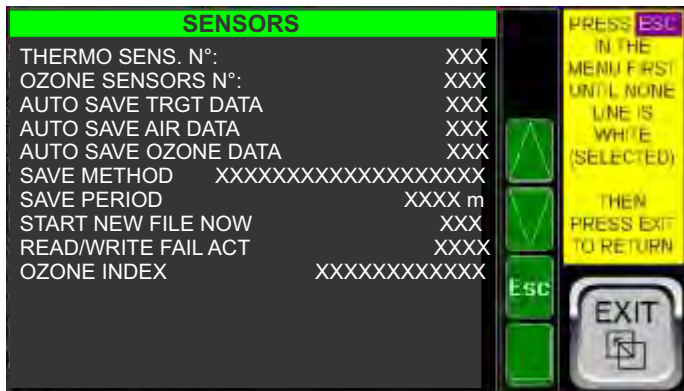

reading. Each time the relay is restarted, a line will be inserted with the zeroed data for separation purposes and restart information. The **TRGTFILE** and **AIRFILE** files will have the following structure: **dd, mm, yyyy, hh, mm, ss, 0, NS, SR, 0, T1, T2, T3 Tn** where day, month, year, hour, minute, second, zero separator, Number of total sensors, Number of sensors OK, responding, Zero separator, Temperature of sensor 1, Temperature of sensor 2 up to Temperature of the last programmed sensor. In the example below we have 3 sensors.

Nome	Data de modificação	Tipo	Tamanho
AIRFILE	23/02/2025 08:01	Arquivo	2 KB
OZFILE	23/02/2025 08:01	Arquivo	2 KB
TRGTFILE	23/02/2025 08:01	Arquivo	2 KB

M03-SENSORS

03.1- Thermo Sens. N°: Enter the number of THM sensors in the network between 1 and 125.

03.2- Ozone Sens. No.: Enter the number of ozone+humidity sensors in the network between 1 and 125.

03.3- Auto Save Trgt Data: (No, Yes), choose whether to save target temperature data from all sensors to the memory card, periodically and automatically. See more details below.

03.4- Auto Save Air Data: (No, Yes). choose whether to save air temperature data from all sensors to the memory card, periodically and automatically. See more details below.

03.5- Auto Save Ozone Data: (No, Yes). choose whether to save ozone readings from all sensors to the memory card, periodically and automatically. See more details below.

03.6- Save Method: (Always to the Same File, New File Each Start). See more details below. **03.7- Save Period:** (10 to 1440 minutes). If you choose 1440, the values will be saved every 24 hours. You can then start from 10 minutes to 24 hours of interval.

03.8- Start New File Now: (No, Yes). You can give a command that is equivalent to turning the relay back on, that is, a new file will be created within the directory related to the «New File Each Start» option, or a separator with zero data will be added to the file related to «Always to the Same File». See more details below.

03.9- Read/Write Fail Act: (None, Log). Choose «Log» if you want an Alarm to occur and to store in the History of read and write failures in these files. **03.10- Ozone Index:** Choose whether you want to show the Ozone+Humidity sensor indexes from the following options: «**Show From 1**», in which the sensors are shown with indexes starting at 1 even if the first sensor in the network has a number greater than 1, or «**Same Address**», in which the ozone sensor indexes are shown on the screens with the same index as the address of each ozone sensor. **NOTE:** The THM sensor indexes are always shown starting at 1 since they must be numbered (addressed) starting at 1 and only after the address of the last THM sensor can the ozone sensors begin to be addressed. **Important:** The network address has nothing to do with the physical positioning of the sensors in the network, and the sensors can be mixed as desired in the physical sequence of the network.

Details of the saving methods reactive to the options in item 03.4 above.

Selecting «Always to the Same File» If «Yes» is selected in items 03.3 and/or 03.4 and/or 03.5 above, the data will be automatically saved in a file structure as described and shown below.

Attention: if «New file Each Start» is selected, these files within the **DATAAUTO** directory will remain inactive, not receiving any more data until «Always to the Same File» is selected again.

The data will be within the **DATAAUTO** directory, with the target data being in the **TRGTFILE** file, the air data being in the **AIRFILE** file and the ozone data being in the **OZFILE** file.

The data will be added (Append) separated by commas, to the file with each reading in Excel CSV format, with each line corresponding to a

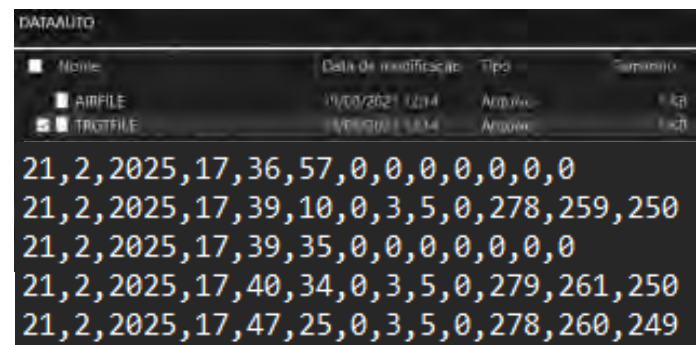

Selecting «**New File Each Start**» If «**Yes**» is selected in items **03.3** and/or **03.4** and/or **03.5** above, the data will be automatically saved in a file structure as described and shown below.

Attention: if «Always to the Same File» is selected, these files within the **DATANEW** directory will remain inactive, not receiving any more data until «New file Each Start» is selected again.

The data will be within the **DATANEW** directory, subdirectory **TARGET** or **AIR** or **Ozone**, always with these same names and each of them will contain new subdirectories **DDMMYYYY**, that is, named with the day, month and year of creation of each one, created each time the relay is turned on again or when the «**Start New File Now**» command is issued. And within each of these last subdirectories will be the data files, named **Thhmm**, that is T plus the hour and minutes for Target files or **Ahhmm**, that is A plus the hour and minutes for Air files.

PROGRAMMING MENU

20- MENU

These data files, named **Thhmm**, will have a line for each period end chosen in item 03.5. with a comma-separated Excel data structure, also with a CSV extension.

Note that for this option, data with zeros is not inserted at each restart for marking, as new files are created at each restart, so this insertion is not necessary for information. Note that until the relay is reset or a «**Start New File Now**» command is given, which is equivalent to reconnecting the relay, the temperature data will be added (Append) to the last file created **Thhmm** or **Ahhmm**, with one line for each reading, in each period as programmed, with the same structure separated by commas as the previous files, i.e.:

dd, mm, yyyy, hh, mm, ss, 0, NS, SR, 0, T1, T2, T3 Tn
 being day, month, year, hour, minute, second, zero separator, Number of total sensors, Number of sensors OK, responding, Zero separator, Temperature sensor 1, Temperature sensor 2 up to Temperature of the last programmed sensor.

In the following examples, with 3 sensors, you can see the file and data structure for the «**New File Each Start**» option.
 First, the structure for Targets:

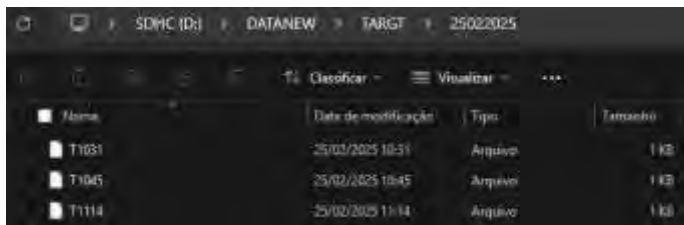
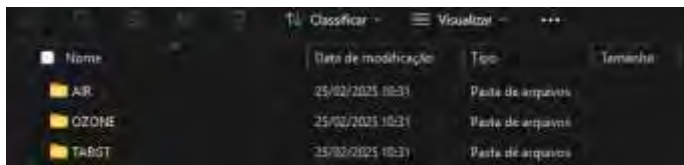

And then the file structure for Air below.

The structures for the Ozone files are identical.

NOTE: Note that the values are shown without the comma, that is, it is the value read x 10. Simply divide everything by 10 to obtain the value with the decimal. Example: where it reads 318, it is equivalent to a temperature of 31.8 °C.

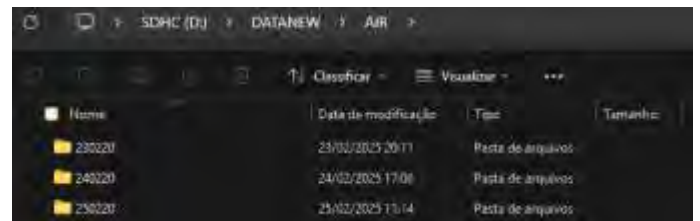
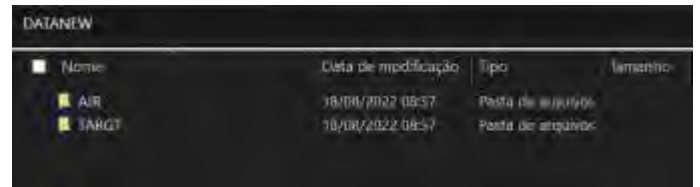

PROGRAMMING MENU

20- MENU

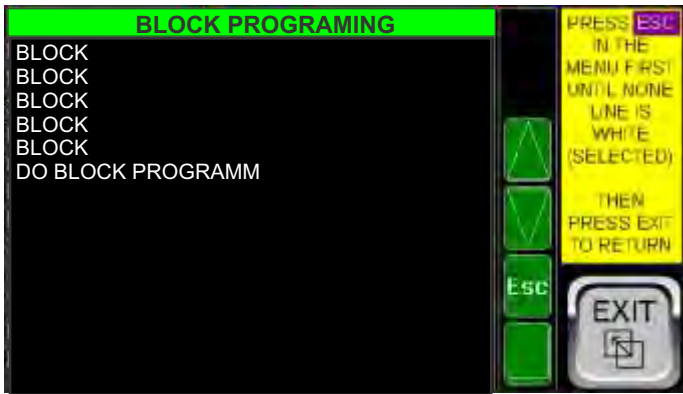

M04- BLOCK PROGRAMING (for THM Sensors only)

This menu allows you to more easily program the parameters related to the target for each sensor. They can be programmed one by one with different values (more on this later) or all at the same time and with the same values if they are all placed in the same block or in up to 5 blocks with different values for each block.

M04.1- BLOCK 1 (same as for blocks 2, 3 and 4)

04.1.1- Start: (1 to 100). Initial sensor number for this block.

04.1.2- End: (1 to 100). Final sensor number for this block.

04.1.3- Target Alarm: **xxxx** °. Degrees Celsius or Fahrenheit, depending on the programming, above which the Alarm will be activated (and not Trip, which is the next level).

04.1.4- Target Trip: **xxxx** °. Degrees Celsius or Fahrenheit, depending on the programming, above which the Trip will be activated (and also the Alarm, since if the Trip signal is automatically activated the Alarm signal will also be activated. The opposite does not occur. If only the Alarm level is reached the Trip will not be activated and the corresponding fault actions, selected in the fault menus, will be triggered.

M04.2- BLOCK 2 - same as block 1

M04.3- BLOCK 3 - same as block 1

M04.4- BLOCK 4 - same as block 1

M04.5- DO BLOCK PROGRAMM

After entering all the block parameters (or just one block with all the sensors), select this submenu and you will be directed to the screen that will execute the automatic programming when confirmed by clicking on the «Proceed?» button with the «Yes» option.

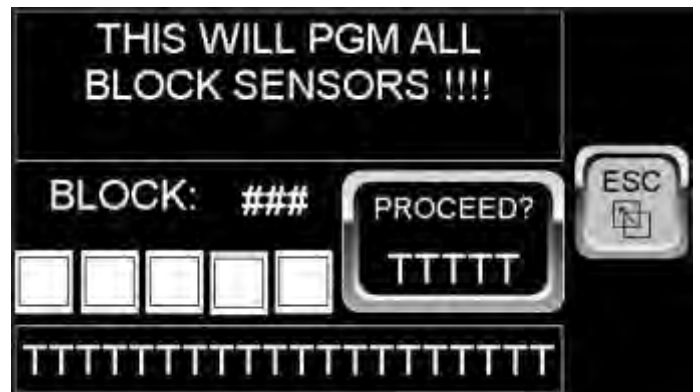

PROGRAMMING MENU

20- MENU

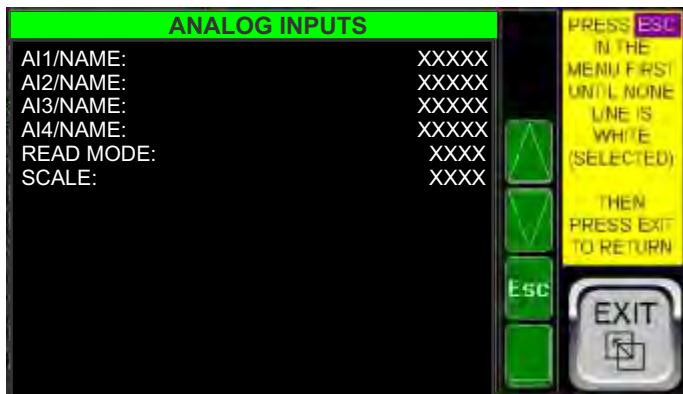

M05-ANALOG INPUTS

- 05.1- AI1/NAME:** Enter the name of the analog input, with up to 5 characters, to facilitate its identification.
- 05.2-AI2/NAME:** Same.
- 05.3-AI3/NAME:** Same.
- 05.4-AI4/NAME:** Same.
- 06.5-Read Mode:** (% , Temp). Reading mode and display on screens, as a percentage in relation to the full scale (5V) or Temperature. The next parameter defines the full scale for the temperature.
- 05.6- Scale:** xxxx. Enter the temperature that is equivalent to the full scale (5V) of the analog inputs.

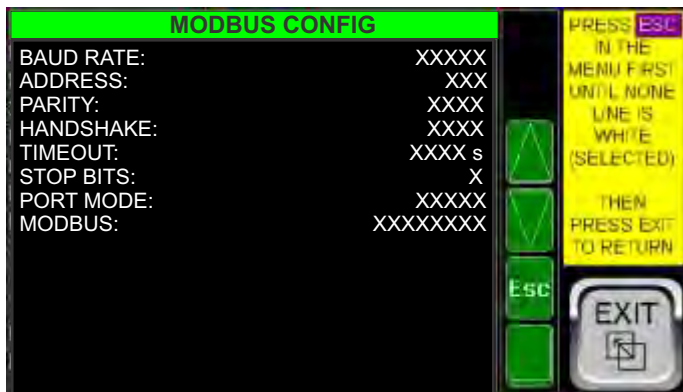

M08-MODBUS CONFIG

This menu is related to the Modbus communication port for the user to optionally connect to the DCS system. (It is not related to the communication port with the sensors)

- 06.1- Baud Rate:** (9600, 19200, 38400) Enter the required Baud Rate.
- 06.2- Address:** (1 to 247): Enter the network node address for this relay.
- 07.3- Parity:** (None, Odd, Even). Choose the required parity.
- 06.4- Handshake:** (None, XON/XOFF, CTS/RTS, MD/HALF), Choose the required Handshake.
- 06.5- Timeout:** (0 to 1023 s). Enter the required Timeout.
- 06.6- Stop Bits:** (1 or 2). Choose the required value.
- 06.7- Port Mode:** (Rs232, Rs485). Select the mode used.
- 06.8- Modbus:** (Active, Inactive). To turn Modbus on or off. If not used, leave it in «Inactive».



M07-PROTECTIONS

This menu is divided into three (1/2, 2/2 and 1/3) the first two referring to the THM system and the third to the ARC-Flash system and will be detailed later.



M07-PROTECTIONS 1/2

In this menu, the parameters relating to the protections shown above will be programmed.

PROGRAMMING MENU

20- MENU

ACTION: The selection possibilities for the Action parameter of each of the faults may include one or more options as follows and informed in the parenthetical part of each fault described below and will not be further detailed: (**None, Log, Alarm, Trip**). In «None» this fault will not be considered. In «Log», it will be logged on the Alarm screen but the Alarm condition will not be triggered. In «Alarm» the fault will be logged and the Alarm condition will be triggered. In **Trip**, the fault will be logged, the Alarm condition will be triggered and the Trip condition will be triggered. **AUX OUTPUT:** The options for all faults are «None», «D.O.3», «D.O.4», «EB1:Aux1», «EB2:Aux2», «EB3:Aux3», «EB4:Aux4»..... «EB8:Aux8». This will not be detailed in each fault description below, as what is described here applies to all of them. Note that the outputs «D.O.1» and «D.O.2» are dedicated to «Alarm» and «Trip» and the outputs D.O.3 and D.O.4 are programmable and are located on the relay, while the others, also programmable, are located on the EBLOCK 88x expansion block.

Note: More than one fault can be assigned to the same output and it will switch if any of the faults assigned to it occurs.



M07.2- TARGET ALARM

This fault will occur if one or more sensors reach the alarm temperature level for the target, programmed for each of them in the corresponding menu.

07.2.1- Action: (None, Log, Alarm). Select the option. Note that there is no «Trip» option.

07.2.2- D. Output: (None, D.O.3, D.O.4, EB1: Aux1 to EB8: Aux8). Select the option.



M07.1- THM S. NOT RESPONDING

This fault will occur if one or more sensors are not responding in the sensor network.

07.1.1- Action: (None, Log, Alarm). Choose the desired option.

07.1.2- Aux Output: (None, D.O.3, D.O.4, EB1: Aux1 to EB8: Aux8). Choose the desired option.

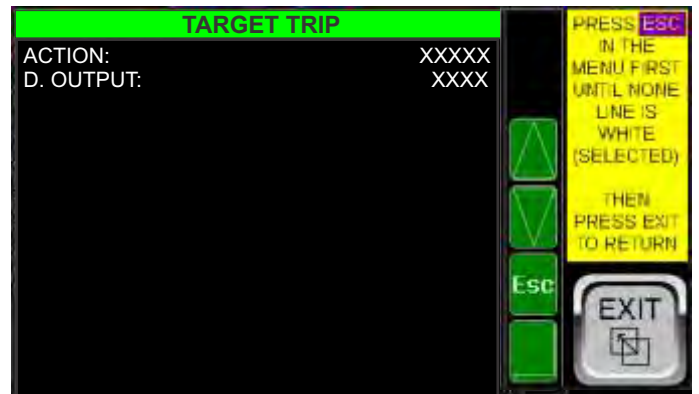

M07.3- TARGET TRIP

This fault will occur if one or more sensors reach the Trip temperature level for the target, programmed for each of them in the corresponding menu.

07.3.1- Action: (None, Log, Trip). Choose the option. Note that there is no «Alarm» option which will also be triggered together with the Trip.

07.3.2- Aux Output: (None, D.O.3, D.O.4, EB1: Aux1 to EB8: Aux8). Choose the option.

PROGRAMMING MENU

20- MENU



M07.4-AIR ALARM

This fault will occur if one or more sensors reach the alarm temperature level for the air (sensor body), programmed for each of them in the corresponding menu.

07.4.1-Action: (None, Log, Alarm). Select the option. Note that there is no «Trip» option.

07.4.2- Aux Output: (None, D.O.3, D.O.4, EB1: Aux1 to EB8: Aux8). Select the option.



M07.6-OZONE ALARM

This fault will occur if one or more sensors reach the ozone level programmed for each of them in the corresponding menu.

07.6.1-Action: (None, Log, Alarm). Select the option. Note that there is no «Trip» option.

07.6.2- Aux Output: (None, D.O.3, D.O.4, EB1: Aux1 to EB8: Aux8). Select the option.



M07.5-AIR TRIP

This fault will occur if one or more sensors reach the Trip temperature level for the air (sensor body), programmed for each of them in the corresponding menu.

07.5.1-Action: (None, Log, Trip). Choose the option. Note that there is no «Alarm» option which will also be triggered together with the Trip.

07.5.2- Aux Output: (None, D.O.3, D.O.4, EB1: Aux1 to EB8: Aux8). Choose the option.



M07.7-OZONE TRIP

This fault will occur if one or more sensors reach the ozone level programmed for each of them in the corresponding menu.

07.7.1-Action: (None, Log, Alarm). Select the option. Note that there is no «Trip» option.

07.7.2- Aux Output: (None, D.O.3, D.O.4, EB1: Aux1 to EB8: Aux8). Select the option.

PROGRAMMING MENU

20- MENU



M07.8- HUMIDITY ALARM

This fault will occur if one or more sensors reach the humidity level programmed for each of them in the corresponding menu.

07.8.1- Action: (None, Log, Alarm). Select the option. Note that there is no «Trip» option.

07.8.2- Aux Output: (None, D.O.3, D.O.4, EB1: Aux1 to EB8: Aux8). Select the option.

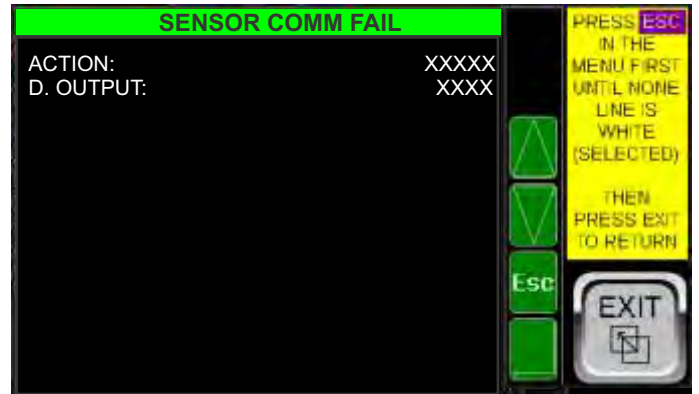

M07.9- SENSOR COMM FAIL

This fault will occur if the sensor network presents a fault, which is shown on the main screen (Ms6) as already described in the section corresponding to this screen and whose fault type is shown on this screen.

07.9.1- Action: (None, Log, Alarm). Choose the desired option. Note that there is no Trip option because this is not an important fault that could trip the system, and therefore can be fixed.

07.9.2- Aux Output: (None, D.O.3, D.O.4, EB1: Aux1 to EB8: Aux8). Choose the desired option.

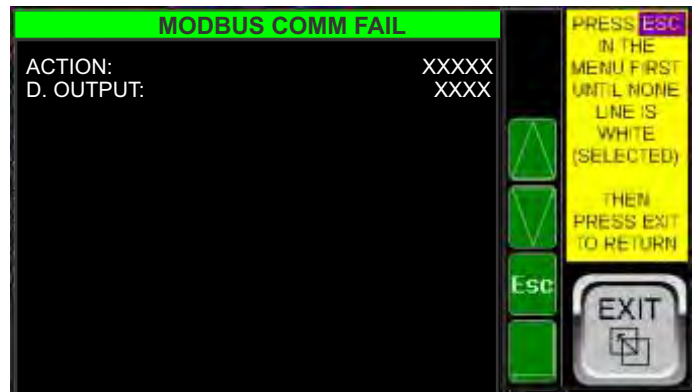

M07.10- MODBUS COMM FAIL

This fault will occur if the sensor network presents a fault, which is shown on the main screen (Ms6) as already described in the section corresponding to this screen and whose fault type is shown on this screen.

07.10.1- Action: (None, Log, Alarm). Choose the desired option. Note that there is no Trip option because this is not an important fault that could trip the system, and therefore can be fixed.

07.10.2- Aux Output: (None, D.O.3, D.O.4, EB1: Aux1 to EB8: Aux8). Choose the desired option.

PROGRAMMING MENU

20- MENU

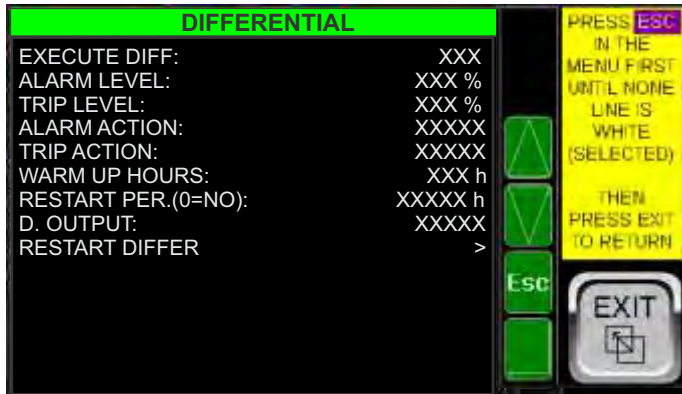

M07.11-DIFFERENTIAL

This fault will occur if the differential fault is programmed to be executed and the temperature rises in relation to the first measurement as programmed.

07.11.1- Execute Diff: (Yes, No). Choose «Yes» to activate this protection or «No» to not activate it.

07.11.2- Alarm Level: Enter the Alarm level as a percentage of the initial reading.

07.11.3- Trip Level: Enter the Trip level as a percentage of the initial reading.

07.11.4- Alarm Action: (None, Log, Alarm). Note that there is no Trip option.

07.11.5- Trip Action: (None, Log, Trip). Note that there is no Alarm option which will occur together with the Trip option.

07.11.6- Warm Up Hours: Enter the warm up time in hours required to take the first measurement. The first measurement is taken with the system warmed up and stabilized. In environments with high variations in ambient temperature, do not choose an alarm or trip level that is too tight, taking into account the variation in ambient temperature as well.

07.11.7- Restart Period: (0=No) Enter the period for the automatic restart of the function, i.e., for taking a new measurement. The restart can also be manual, at any time, performed in item 08.7.9 below. Note that if zero is entered, it is equivalent to never performing the automatic restart.

07.11.8- Aux Output: (None, D.O.3, D.O.4, EB1: Aux1 to EB8: Aux8). Choose the desired option.

07.11.9- Restart Differ: This item directs you to the screen that will perform the restart of the differential (shown below), performing a new initial reading when the action is confirmed in the «Proceed?» button with the «Yes» option.

07.11- RESTART DIFFERENTIAL: If the green button is pressed, there will be a new reading of the initial reference temperatures for the differential after the new heating period (Warm) has been counted.

If the yellow button is pressed, there will be a new reading immediately, without the heating period. Only use the yellow button if you are sure that the system is at a stable temperature at the moment.]

This screen will also appear after the relay is switched off in a valid differential condition, i.e. with the indication «Valid» so that the operator can decide whether to continue with the data previously read and saved for the differential reference or to start the differential with a new reading.

To keep the old data, simply press «ESC».



M07.12- OPERATING TIME

This fault will occur if the fault is programmed to be executed in «Action» and the On Time is greater than the programmed one. This fault is used to schedule any preventive maintenance on the system, although the Zyggot system itself does not require any preventive maintenance for at least 10 years.

07.12.1- Action: (None, Log, Alarm). Choose the desired option. Note that there is no Trip option.

07.12.2- Hours: Enter the number of On hours to activate this protection (max = 250000 h).

07.12.3- Aux Output: (None, D.O.3, D.O.4, EB1: Aux1 to EB8: Aux8). Choose the desired option.

PROGRAMMING MENU

20- MENU



M07.13-GROUP

This menu is subdivided into 5 (Group 1 to Group 5). Only the programming of group 1 will be detailed. The others are identical.



M07.14 - PROTECTIONS 1/2

In this menu, the parameters related to the protections shown above will be programmed. The numbering of the submenus will follow the sequence of menu 7- Protections



M09.11-GROUP 1

This fault will occur if any of the sensors assigned to this group are in Alarm or Trip condition.

07.13.1- Target Alarm Action: (None, Log, Alarm). Note that there is no Trip option.

07.13.2- Target Trip Action: (None, Log, Trip). Note that there is no Alarm option which will occur together with the Trip option.

07.13.3- Air Alarm Action: (None, Log, Alarm). Note that there is no Trip option.

07.13.4- Air Trip Action: (None, Log, Trip). Note that there is no Alarm option which will occur together with the Trip option.

07.13.5- Target Alarm Out: (None, D.O.3, D.O.4, EB1: Aux1 to EB8: Aux8). Choose the desired option. **07.13.6- Target Trip Out:** (None, D.O.3, D.O.4, EB1: Aux1 to EB8: Aux8). Choose the desired option.

07.13.7- Air Alarm Out: (None, D.O.3, D.O.4, EB1: Aux1 to EB8: Aux8). Choose the desired option.

07.13.8- Air Trip Out: (None, D.O.3, D.O.4, EB1: Aux1 to EB8: Aux8). Choose the desired option.



M07.15-ANALOG 1 ALARM

This fault will occur if the fault is programmed to be executed in «Action» and the value of analog input 1 exceeds the programmed level.

07.15.1- Action: (None, Log, Alarm). Choose the desired option. Note that there is no Trip option.

07.15.2- Level High: Enter the level in % of full scale.

07.15.3- D. Output: (None, D.O.3, D.O.4, EB1: Aux1 to EB8: Aux8). Choose the desired option.

M7.16-ANALOG 2 ALARM - same as M7.15

M7.17-ANALOG 3 ALARM - same as M7.15

M7.18-ANALOG 4 ALARM - same as M7.15

PROGRAMMING MENU

20- MENU

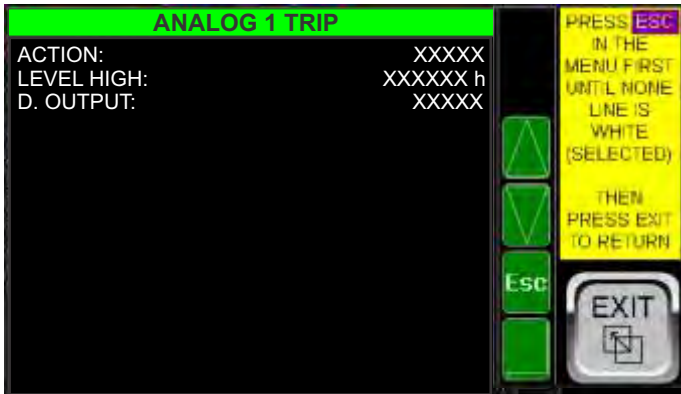

M07.19-ANALOG 1 TRIP

This fault will occur if the fault is programmed to be executed in «Action» and the value of analog input 1 exceeds the programmed level.

07.19.1- Action: (None, Log, Alarm). Choose the desired option. Note that there is no Alarm option which will occur together with the Trip.

07.19.2- Level High: Enter the level in % of the full scale.

07.19.3- Aux Output: (None, D.O.3, D.O.4, EB1: Aux1 to EB8: Aux8). Choose the desired option.

M7.20-ANALOG 2 TRIP - same as M7.19

M7.21-ANALOG 3 TRIP - same as M7.19

M7.22-ANALOG 4 TRIP - same as M7.19

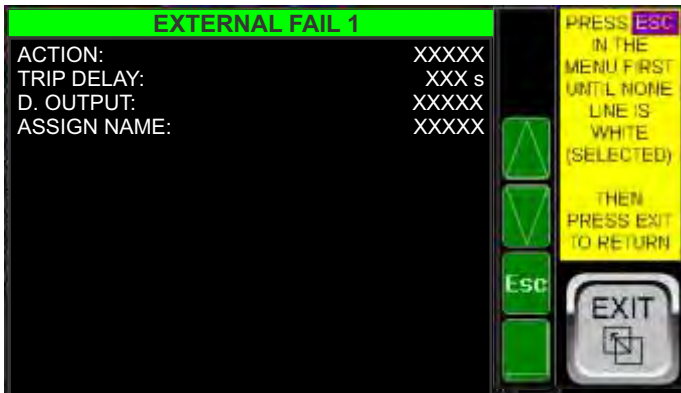

M07.23-EXTERNAL FAIL 1

This fault will occur if the fault is programmed to be executed in «Action» and the corresponding digital input becomes active.

07.23.1- Action: (None, Log, Alarm, Trip). Choose the desired option. Note that if there is no Alarm option, the Trip will not be activated, and if the Trip option is selected, the Trip output and the Alarm output will be activated if configured for this purpose. If «Log» is selected, only the fault will be logged on the Alarms and History screen, but the alarm or trip condition will not be activated.

07.23.2- Trip Delay: Delay time that occurs after the digital input becomes active and the fault is detected.

07.23.3- Aux Output: (None, D.O.3, D.O.4, EB1: Aux1 to EB8: Aux8). Choose the desired option.

07.23.4- Assign Name: Enter the name of the system with up to 5 characters to facilitate its identification in the system.

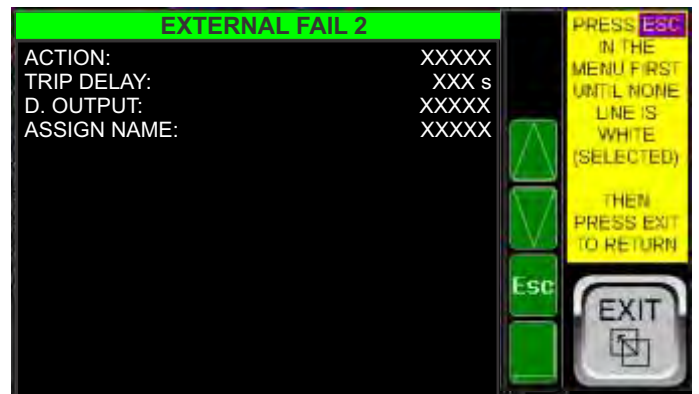

M07.24-EXTERNAL FAIL 2

This fault will occur if the fault is programmed to be executed in «Action» and the corresponding digital input becomes active.

07.24.1- Action: (None, Log, Alarm, Trip). Choose the desired option. Note that if there is no Alarm option, the Trip will not be activated, and if the Trip option is selected, the Trip output and the Alarm output will be activated if configured for this purpose. If «Log» is selected, only the fault will be logged on the «Alarms» and «History» screens, but the alarm or trip condition will not be activated.

07.24.2- Trip Delay: Delay time that occurs after the digital input becomes active and the fault is detected.

07.24.3- Aux Output: (None, D.O.3, D.O.4, EB1: Aux1 to EB8: Aux8). Choose the desired option. **07.24.4- Assign Name:** Enter the name of the system with up to 5 characters to facilitate its identification in the system.

PROGRAMMING MENU

20- MENU



M08- TARGET ALARM LEVELS

In these Submenus you can enter each Alarm temperature level for the target or edit the levels that were automatically set by the Group Programming submenu.

M09- TARGET TRIP LEVELS

In these Submenus you can enter each Trip temperature level for the target or edit the levels that were automatically set by the Group Programming submenu.



M08.1- TARGET 01 - 10 ALARM LEVELS

M08.1.1- A1 to A8: Enter or edit the level in degrees Celsius or Fahrenheit for the target alarm level.

M09.1- TARGET 01 - 10 TRIP LEVELS

M09.1 - A1 a A10 Entre ou edite o nível em graus Centígrados ou Fahrenheit para o nível de alarme do alvo.

- M08.2- TARGET 11 - 20 ALARM LEVELS
- M08.3- TARGET 21 - 30 ALARM LEVELS
- M08.4- TARGET 31 - 40 ALARM LEVELS
- M08.5- TARGET 41 - 50 ALARM LEVELS
- M08.6- TARGET 51 - 60 ALARM LEVELS
- M08.7- TARGET 61 - 70 ALARM LEVELS
- M08.8- TARGET 71 - 80 ALARM LEVELS
- M08.9- TARGET 81 - 90 ALARM LEVELS
- M08.10- TARGET 91 - 100 ALARM LEVELS
- M08.11- TARGET 101 - 110- ALARM LEVELS
- M08.12- TARGET 111 - 120- ALARM LEVELS
- M08.13- TARGET 121 - 125- ALARM LEVELS

same as M08.1.1 above

- M09.2- TARGET 11 - 20 TRIP LEVELS
- M09.3- TARGET 21 - 30 TRIP LEVELS
- M09.4- TARGET 31 - 40 TRIP LEVELS
- M09.5- TARGET 41 - 50 TRIP LEVELS
- M09.6- TARGET 51 - 20 TRIP LEVELS
- M09.7- TARGET 61 - 70 TRIP LEVELS
- M09.8- TARGET 71 - 80 TRIP LEVELS
- M09.9- TARGET 81 - 90 TRIP LEVELS
- M09.10- TARGET 91 - 100 TRIP LEVELS
- M09.11- TARGET 101 - 110 TRIP LEVELS
- M09.12- TARGET 111 - 120- TRIP LEVELS
- M09.13- TARGET 121 - 125- TRIP LEVELS

same as M09.1.1 above

PROGRAMMING MENU

20- MENU

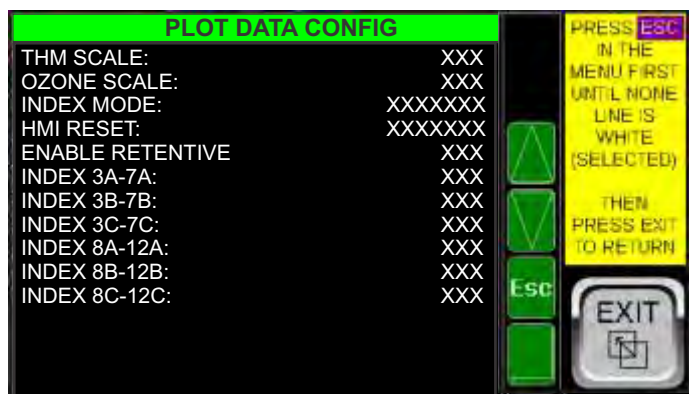

M10-PLOT DATA CONFIG

This menu allows you to configure the parameters related to the curves (Plot) shown previously in this manual.

- 10.1- Scale:** Enter the temperature scale equivalent to the full scale or 100% of the vertical axis of each Plot shown on screens T1 to T12. This number appears in the left corner of each screen from 1 to 12 of the curves.
- 10.2- INDEX MODE:** (Display, Menu). If «Display» is selected, the operator can enter the numbers (addresses) of the network sensors directly on each curve screen. If «Menu» is selected, the sensor numbers must be entered in this menu (below).
- 10.3- HMI Reset:** (Enable, Disable). If «Enable» is selected, the operator will be able to command the reset of the curves on the display of each one. If «Disable» is selected, the curves will not be reset.
- 10.4- Enable Retentive:** (No, Yes). Enables or disables the recording of curves related to the T18 Screen Plot, as detailed in the operation screens section.
- 10.5- Index 3A - 7A:** Enter the sensor number from 1 to 125 that will be plotted on the curves of screens T3 to T7 (5 curves with different sampling times) in curve A (Green) of each screen.
- 10.6- Index 3B - 7B:** Enter the sensor number from 1 to 125 that will be plotted on the curves of screens T3 to T7 (5 curves with different sampling times) in curve B (Yellow) of each screen.
- 10.7- Index 3C - 7C:** Enter the sensor number from 1 to 125 that will be plotted on the curves of screens T3 to T7 (5 curves with different sampling times) in curve C (Violet) of each screen.
- 10.8- Index 8A - 12A:** Enter the sensor number from 1 to 125 that will be plotted on the curves of screens T8 to T12 (5 curves with different sampling times) in curve A (Green) of each screen.
- 10.9- Index 8B - 12B:** Enter the sensor number from 1 to 125 that will be plotted on the curves of screens T8 to T12 (5 curves with different sampling times) in curve B (Yellow) of each screen.
- 10.10- Index 8C - 12C:** Enter the sensor number from 1 to 125 that will be plotted on the curves of screens T8 to T12 (5 curves with different sampling times) in curve C (Violet) of each screen.

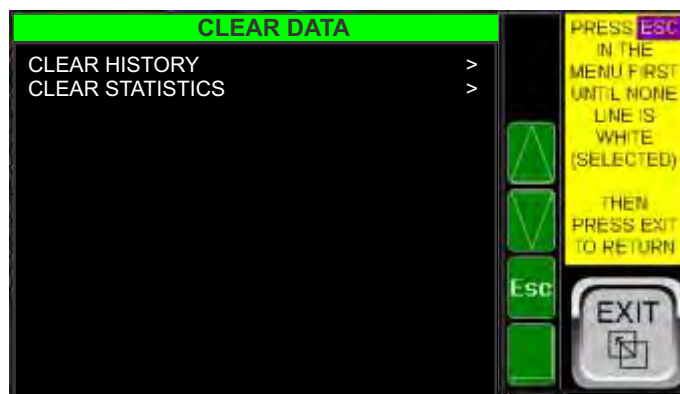

M11-CLEAR DATA

This menu directs you, through items, to Clear screens (data reset)

11.1- Clear History: Where you can clear the fault and event report that is displayed on the **HISTORY** screen and that cannot be done directly on the screen so that the operator who does not have the menu password can erase this data. It is recommended that only engineering personnel have access to the programming menu for this reason and also to avoid inadvertently changing important parameters.

11.2- Clear Statistics: Where you can reset the total number of Alarms and Trips that appear on the **MS3** screen (Main Screen 3). The same observations regarding the password apply as in the item above.

Tela Clear History

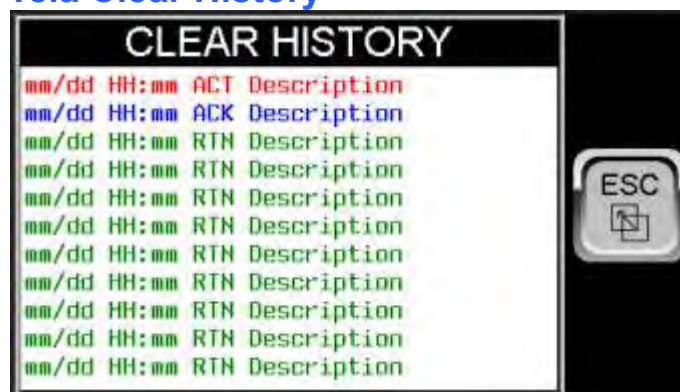

Tela Clear Statistics



PROGRAMMING MENU

20- MENU



M12- BACKUP / RESTORE DATA

M12.1- Enable Autorun: Auto Run must be enabled as well as Auto Load if it is desired to have the Fail-Safe system operational. After Auto Load has been executed, if the relay detects that the program is missing or corrupted.

M12.2- Enable AutoLoad: Must be enabled in the same way as described above.

M12.3- Flash Backup: This submenu directs you to the screen below where you can clear the previously executed backup or perform a first or new backup of the entire RAM memory to the internal Flash memory. This internal backup is used in the event of a Fail-Safe action with **Auto Load** and **Auto Run**.

Only execute the Make Backup command after having programmed all the parameters and being sure that the relay is operating correctly and without active or uncleared faults on the alarm screen.

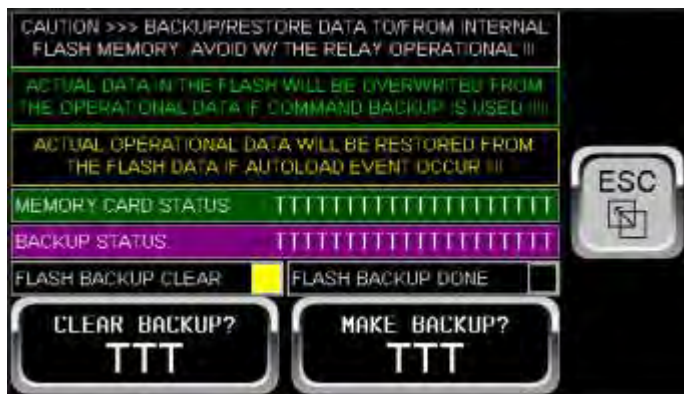

In addition to the Clear Backup and Make Backup buttons and the Cleared or Done indications, there is a memory card status field, as previously described, and a Backup Status field, with the messages described previously on the MS10 Screen, which can be: 1- STANDBY / 2- OK - PROCEED / 3- ERROR - CHECK CARD / 4- DONT BACKUP ON FAIL / 5- OK - DONE / 6- WRITING / 7- READING / 8- BUSY.

Note that the Clear Backup and / Make Backup command buttons are invisible if the conditions for these commands are not suitable at the time.

M12.4- CLONE PARAMETERS

This submenu takes you to the Clone Parameters screen below.

WARNING: This action, if «Restore» is commanded, will overwrite all programming parameters with those contained in the memory card, in the specific file.

To use this function, a previously formatted memory card, with a maximum of 32 Gb, must be inserted in the upper slot of the relay. You can command «Backup» to save a new file with the data or «Restore» to restore the same.

In this way, if several Zygote V5F/TOH Relays are used with the same programming, simply program one of them and clone the data in the other relays.

This action does not save or restore the programming password, which is in fact one of the parameters.

On the screen below, you can see that there are two fields, one with the card status messages as described in the explanation of the Info 4 screen and another with the Backup status messages as described previously on the MS10 Screen, which are: 1- STANDBY / 2- OK - PROCEED / 3- ERROR - CHECK CARD / 4- DONT BACKUP ON FAIL / 5- OK - DONE / 6- WRITING / 7- READING / 8- BUSY.

Note that the Backup and Restore command buttons are invisible if the conditions for these commands are not suitable at the time.

Note: Unlike the Flash Backup command, which copies the entire RAM memory to a non-volatile internal memory, the Clone Parameters command described here only saves the values of the parameters entered in the programming menu and serves as documentation to be saved, such as possible restoration of parameters to a previous condition when changes are made to the programming or, as already mentioned, cloning the same parameters in other relays of the same plant, for example.

To clone the parameters to other relays, copy the «Datacard» file from the memory card of the relay that generated the file to be cloned to the cards of the other relays onto a computer and then run the Restore command on each of them. Attention: In this case, be careful not to run the Backup command on the other relays before running the Restore command.



PROGRAMMING MENU

20- MENU

M13-ETHERNET

The ZYGGOT V5F/TOH Relay has **ETHERNET** communication and can be accessed from anywhere on the planet. Several communication protocols are incorporated, and the user simply needs to define the communication parameters in the programming screens below and use it.

For example, it is possible to obtain all temperature readings and flag statuses from a computer or mobile device or even interface with a DCS system anywhere, as long as there is access to Ethernet and the relay is connected to a local LAN network with access to an external WAN network and the addresses programmed in the relay are known.

It is possible to perform remote parameterization of the relay if necessary, such as alarm and trip levels, etc.

It is also possible for the manufacturer to perform eventual firmware updates remotely, if necessary.

The available protocols are:

ICMP - Internet Control Message Protocol.

SRTP - Service Request Transport Protocol.

TCP/IP - Transmission Control Protocol (Modbus TCP Server or Modbus Slave).

ETHERNET/IP - Internet Protocol (Ethernet IP Server).

FTP - File Transfer Protocol

HTTP - Hypertext Transfer Protocol.

ASCII Over TCP/IP - ASCII Transmission Control Protocol.

NTP - Network Time Protocol.

This manual does not intend to cover each protocol in depth. It is up to the user to know the protocol they intend to use.

Below is a brief description of each Protocol and their limitations in this application.

ICMP - Internet Control Message Protocol. Internet Control Message Protocol (ICMP) is a protocol that is part of the IP Protocol, defined by RFC 792. It is used to communicate network layer information, and its most common use is to provide error reports to the original source. Any computer that uses IP must accept ICMP messages.

Although several tools are possible in this protocol, the Zyggot V5F/TOH relay only implements the Ping function, which can be used to check whether a device is responding to commands, i.e. is accessible on the network.

SRTP - Service Request Transport Protocol. Service Request Transfer Protocol (SRTP) is a GE Fanuc Automation protocol that allows a remote SRTP client to request services from an SRTP server. In this case, the ZYGGOT V5F/TOH relay acts as an SRTP server that responds to requests from one or more SRTP Clients.

Since SRTP was originally designed to support the services provided by the GE Fanuc Series 90, the ZYGGOT V5F/TOH SRTP protocol does not support all possible SRTP services. The ZYGGOT V5F/TOH Relay's implementation of SRTP is mainly limited to the services required for the exchange of registration data.

Configuration:

Port Used: 18245 TCP

Maximum Number of Connections: 16

The following SRTP service requests are supported by ZYGGOT V5F/TOH Relay.

0 PLC_SSTAT

1 PLC_LSTAT

4 READ_SMEM

7 WRITE_SMEM

33 CHG_PRIV_LEVEL

67 RET_CONFIG_INFO

79 SESSION_CONTROL

97 PLC_FEATURES_SUPP

Tipos de Registro:

8 %R 16 bit

10 %AI 16 bit

12 %AQ 16 bit

16 %I 8 bit

18 %Q 8 bit

20 %T 8 bit

22 %M 8 bit

30 %S 8 bit

70 %I 1 bit

72 %Q 1 bit

74 %T 1 bit

76 %M 1 bit

84 %S 1 bit

TCP/IP - Transmission Control Protocol (Modbus TCP Server). The TCP/IP protocol is an acronym for Transmission Control Protocol, used to send and receive data on the web.

The TCP/IP protocol is the language of computers and specifies how data is exchanged over the Internet.

Most computers communicate using TCP/IP, providing end-to-end communications.

Highly scalable and widely used, this protocol requires little central management and was designed to make networks reliable, with the ability to automatically recover in the event of a device failure.

Each device has an IP address that identifies it, allowing it to communicate and exchange data with other connected devices.

Configuration:

Port Used: 502 TCP

Maximum Number of Connections: 16

Note: Modbus must be enabled on the Zyggot V5F/TOH relay.

PROGRAMMING MENU

20- MENU

ETHERNET/IP - Internet Protocol (Ethernet IP Server).

The Internet Protocol (IP) is the network layer communications protocol in the Internet protocol suite for relaying datagrams across network boundaries (Maintained by ODVA.org). Its routing function enables the interconnection of networks and essentially establishes the Internet.

IP is tasked with delivering packets from the source host to the destination host based solely on the IP addresses in the packet headers. To do this, IP defines packet structures that encapsulate the data to be delivered. It also defines addressing methods that are used to label the datagram with source and destination information.

Configuration:

Ports Used: 44818 TCP or 2222 UDP

Maximum Number of Connections: 2

Start Send (Produced) Register = R2001 /// Words Count = 248

Start Received (Consumed) Register = R2501 /// Words Count = 199 ///

Status Register = R5513

FTP - File Transfer Protocol

This is the protocol that allows file transmission over the network. Through it, you can read and access files on the memory card inserted in the respective slot of the relay, where temperature readings, etc., are recorded. It is a standard/generic protocol that is independent of hardware for transferring files and is also a transfer program.

Data transfer in computer networks usually involves transferring files and accessing remote file systems (with the same interface used for local files). FTP is based on TCP, but predates the TCP/IP protocol stack, and was later adapted to it. It is the standard for transferring files.

Configuration:

Ports Used: 20 and 21 TCP

Maximum Number of Connections: 4

User Name 1 (Read Only) = Z_FTP_USER /// Password = 899468 ///

User Name 2 (Read / Write) = Z_FTP_VRX /// Password = xxxx

HTTP - Hypertext Transfer Protocol.

The Hypertext Transfer Protocol is a communication protocol (at the application layer according to the OSI Model) used for distributed and collaborative hypermedia information systems. It is the basis for data communication on the World Wide Web.

Hypertext is structured text that uses logical connections (hyperlinks) between nodes containing text. HTTP is the protocol for the exchange or transfer of hypertext.

Configuration:

Port Used: 80 TCP

Maximum Number of Connections: 1

User Name: = ZYGGOT_WS

Password: 9387

ASCII Over TCP/IP - ASCII Transmission Control Protocol.

The ASCII Transmission Control Protocol, or ASCII TCP, is a query/response/question-and-response communication protocol in which a host PC uses ASCII characters to send commands to a device and receive responses from the device.

This protocol is designed to send and receive ASCII data over the Zyggot Relay's Ethernet port. The Relay acts as a server when using this protocol.

Configuration:

Port Used: Entered in Configuration.

Tx Trigger: %M100 (transmits 500 Bytes when set = 1

Tx Bytes (8 bits) 500 Bytes (250 Words) in the sequence Bytes 1 and 2 form Word 1 containing the temperature of Target 1, Bytes 2 and 3 containing the temperature of Target 2 and so on until completing 100 sensors, when the Air temperatures of Sensor 1, Sensor 2 etc. are completed until completing 100 sensors, therefore completing 400 Bytes (200 Words).

Rx Copy Trigger: %M99 (copies 504 Bytes (252 Words) when set = 1 for the alarm and Trip parameters. Before being set, the user must transmit all the Bytes already configured as half a Word each, referring to the integer value of the alarm levels for each sensor.

Rx Bytes (8 Bits) 504 Bytes (252 Words): The first 500 Bytes must form 250 Words referring to the target alarm levels for 100 sensors, then Trip levels for 100 sensors and the last 4 Bytes must form the 2 words referring to the alarm and trip levels for all sensors (always the same for all).

Maximum number of Connections: 1

NTP - Network Time Protocol.

NTP is a protocol for synchronizing equipment clocks based on the UDP protocol on port 123. It is used to synchronize the clock of a set of equipment and devices in data networks with variable latency. NTP allows you to keep the clock of an equipment synchronized with the correct time at all times and with great accuracy.

Configuration: Five NTP server addresses are predefined in Brazil. Upon request, we can define any other server worldwide.

The factory predefined servers are as follows:

- a.st1.ntp.br
- b.st1.ntp.br
- c.st1.ntp.br
- d.st1.ntp.br
- gps.st1.ntp.br

PROGRAMMING MENU

20- MENU

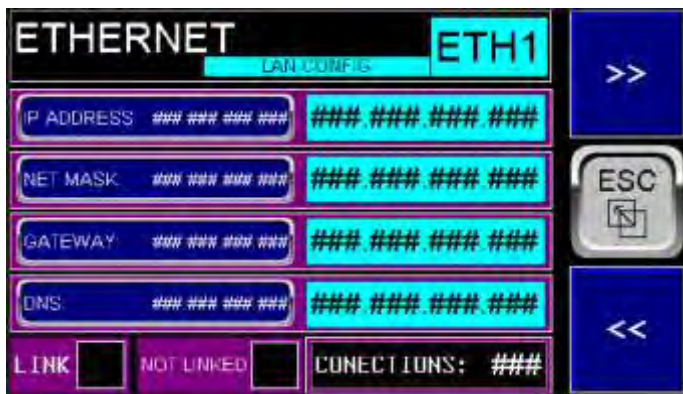

M13A- ETHERNET - LAN CONFIG

M13A.1- IP ADDRESS: Enter the address of the Zyggot V5F/TOH relay on the LAN network.
M13A.2- NET Mask: Enter the number corresponding to the network mask. Normally 255.255.255.0
M13A.3- Gateway: Enter the number corresponding to the Gateway if necessary. If not necessary, leave it at 0.0.0.0
M13A.4- DNS: Enter the address of the Domain Name Server if necessary. If not used, leave it at 0.0.0.0
 This screen also shows whether the Ethernet cable is connected or not and the number of connections. Note: the number of connections may eventually show «zero» even though it is connected if the transmissions are not repetitive and because it is very fast, there is not enough time to show it on the screen.



M13C- ETHERNET - ICMP (PING)

This screen, like the corresponding screen in the **Report Menu**, allows you to test whether a specific device on the network is responding, i.e., is active on the network.
M13C.1- PING ADDRESS: Enter the address to perform the ping.
M13C.2- PING RESPOND TIME: Shows the time in milliseconds that the device took to respond.
M13C.3- Tx and Rx: Shows whether it is transmitting or receiving data.
M13C.4- PING TIMEOUT: If the device does not respond in less than 1 second, it will indicate Timeout, i.e., it is not responding.
M13C.5- STAR and STOP: Starts and stops the PING. When exiting the screen, a Stop is automatically given.

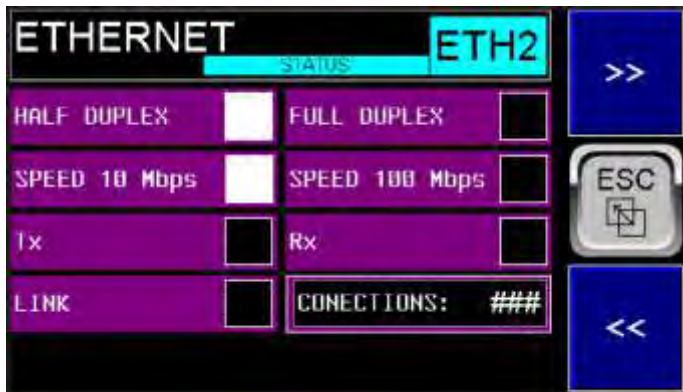

M13B- ETHERNET - STATUS

This screen only shows the various connection statuses, and does not have any fields to be entered.
 The statuses shown are:
M13B.1- HALF DUPLEX or FULL DUPLEX: Shows the connection mode.
M13B.2- SPEED 10 Mbps or 100 Mbps: Shows the connection speed.
M13B.3- Tx and Rx: Shows whether data is being transmitted or received.
M13B.4- LINK: Whether the Ethernet cable is connected (Link) or not and the number of connections. Note: the number of connections may eventually show "zero" but it is connected if the transmissions are not repetitive and because they are very fast there is not enough time to show it on the screen.

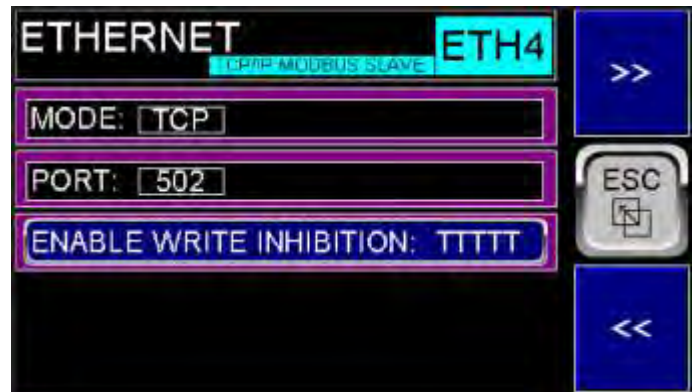

M13D- ETHERNET - TCP/IP PROTOCOL - MODBUS SLAVE

This screen refers to the main protocol of the Zyggot V5F/TOH relay, which allows full Modbus operation, with all functionalities and valid addresses, as well as offsets, etc.

The SUPERGER program provided free of charge by Varixx allows, among other functionalities, complete testing of the Modbus Over Ethernet connection with a computer connected to the Zyggot V5F/TOH relay.

PROGRAMMING MENU

20- MENU



Ethernet IP. Not enabled in this version, so it is always set to "Disabled"

M13E.7 - CONNECTED: Indicates that the Ethernet connection is OK.

M13E.8 - DATA VALID (in the Consumed section): For informational purposes only on this screen. The corresponding word in the Ethernet IP server table (%R3328) must be set to value 1, that is, its bit 1 set when the data is valid to be written to the relay after a new writing page is selected. (Note not enabled in this version. Only page 0 will be effective - see table).

M13E.9 and M14E10 - CONNECT CLASS 3 and CONNECT CLASS 1: For informational purposes only.

M13E-ETHERNET IP PROTOCOL

This screen refers to the Ethernet IP protocol. Unlike the TCP/IP (Modbus Over Ethernet) protocol described above, the data read and written will be transferred all at once, respecting the maximum number of words, as described below.

M13E.1- READING PAGE: From 0 to 16 for reading up to 128 words per page. Corresponds to record %R2927 in the Ethernet IP Server table.

M13E.2- REGISTERS (PRODUCED): For informational purposes only. Always %R2801 to %R2928: will contain the various words with data according to the ETHERNET IP Server table later in this manual.

M13E.3- DATA VALID (in the PRODUCED section): For informational purposes only. Only for informational purposes on this screen. The corresponding word in the Ethernet IP Server table (%R2928) will have the value 1, that is, its bit 1 will be set when the data is valid after the page to be read has been changed. If there is no page change, this bit will remain set indefinitely and, if there is a page change, it will briefly go to zero and then to 1 again when the data read is changed.

M13E.4- WRITING PAGE: From 0 to 16 to write up to 128 words on each page. Corresponds to register %R3226 in the Ethernet IP Server table. (Note: Not enabled in this version. Only page 0 will be effective - see table).4

M13E.5- REGISTERS (CONSUMED): For informational purposes only. Always %R3201 to %R3328: will contain the various words to be written to the relay with data according to the ETHERNET IP SERVER table later in this manual. (Note: Not enabled in this version. Only page 0 will be effective - see table).

M13E.6- PROGRAM PERMISSION: It can be set to "Enabled" or "Disabled" to allow or not the programming of the relay parameters via

PROGRAMMING MENU

20- MENU



M13F-ETHERNET-FTP PROTOCOL - FILE TRANSFER PROTOCOL

This screen refers to the protocol that enables reading and copying of files stored on the ZYGGOT relay memory card, allowing you to obtain historical data records of temperature readings, for example. To access any file on the card, you must know its name as recorded on the card. You must use the file name and its full path (with directories and subdirectories, if any), as in the examples below.
 Assuming that the relay IP is 192.168.1.10 and you want to read the log.txt file, which is in the root directory of the card
 Then type in the search field:
192.168.1.10/log.txt and press Enter.



Aparecerá uma tela pedindo Login e Senha. Uma vez inserido os dados corretos de login e senha o arquivo será lido e poderá ser salvo no computador.

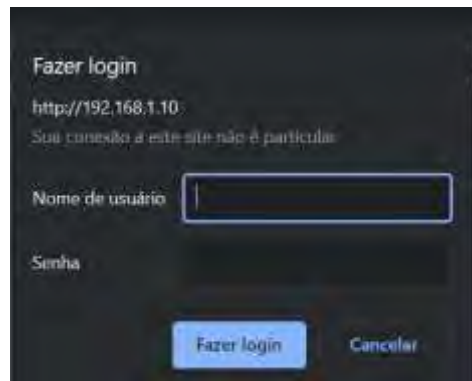

- M13F.1- USER 1 - USER NAME:** Informational only. Always **Z_FTP_USER**.
- M13F.2- PASSWORD:** Informational only. Always **99468**
- M13F.3- READ ONLY.** Informational only.
- M13F.4- USER 2 - USER NAME:** Informational only. Always **Z_FTP_VRX**
- M13F.5- PASSWORD:** Informational only. Always **8799**.



M13G-ETHERNET-HTTP PROTOCOL - WEB SERVER

This screen refers to the **HTTP** or **HTTPS** protocol that allows communication with Browsers using **Hypertext Transfer Protocol**.
M13G.1- USER NAME: For informational purposes only. Always **ZYGGOT_WS**.
M13G.2- PASSWORD: For informational purposes only. Always **9387**



M13H-ETHERNET IP

This screen refers to the **ASCII OVER TCP/IP** protocol.
M13H.1- BY NUMBER: Enter the desired port.
M13H.2- Tx BYTES: For information purposes only. Always 500 (250 Words).
M13H.3- Tx TRIGGER (%M100): When this flag is set to one, 500 Bytes will be transmitted in ASCII format, which must be combined (transformed into 250 16-bit Words that will contain the target and air temperatures of up to 125 sensors).
M13H.4- Rx BYTES: For informational purposes only. Always 506 (253 Words).
M13H.5- COPY ENABLED: Indicates whether copying of buffer records to real records is currently enabled. To indicate «enabled», the «Status Received» must be ok and there must be no «Rx Overflow» or «Socket» errors.
M13H.6- STATUS RECEIVED: Indicates that a successful reception of 504 Bytes (252 Words) occurred.
 After writing the data to be programmed, as per the table at the end of this manual, when setting the Flag corresponding to «Copy Trigger» the data is copied to the corresponding parameters of the Zyggot V5F/TOH relay.

This data will be transferred to the parameters according to the table at the end of this manual.

PROGRAMMING MENU

20- MENU

M13H.6- COPY TRIGGER: In this field choose the method to execute the Copy of the data from the Buffer region to the real parameter registers. You can choose two options, namely: «%M99» or «BYTE T».

If %M99 is selected, at the end of data transmission to the relay, the %M99 Flag must be set to validate the data, when the relay will copy the data to the real parameter registers and reset the %M99 flag. To set the %M99 Flag, the normal TCP/IP Protocol must be used.

If BYTE T (Byte Termination) is selected, the last bit of the second transmitted word (composed of Bytes 3 and 4) must be set. The first word (Bytes 1 and 2) must contain the number of bytes to be transmitted to the relay (always 506).

After writing the data to be programmed, starting from Byte 5 and 6, according to the table at the end of this manual, when setting the «Copy Trigger» Flag (%M99 or BYTE T), the data is copied from the internal buffer region to the real parameters of the Zyggot V5F/TOH relay.

- M13H.7- Rx OVERFLOW STATUS:** Indicates Overflow error in reception.
- M13H.8- Tx OVERFLOW STATUS:** Indicates Overflow error in transmission.
- M13H.9- SOCKET STATUS:** Indicates Socket error.

IMPORTANT NOTE: Always prefer to program the parameters directly on the relay or through the memory card, as described in this manual, for safety reasons. This protocol is accessible mainly because it allows you to read up to 250 target and air temperature readings. The part related to writing data is operational but should be avoided due to the possibility of programming errors and the possibility of even overwriting important data and rendering the relay inoperative, requiring factory maintenance. Therefore, either do not use the programming function using this method or use it with extreme caution.

It is more practical and simple to obtain temperature data, etc., using the TCP/IP Protocol, described above, where you can implement all Modbus over Ethernet communication and obtain all internal data from the Zyggot V5F/TOH Relay, in addition to writing all parameters. However, it is possible to use the ASCII Over TCP/IP protocol to obtain temperature data from the sensors, but the user will have to convert each 2 ASCII bytes into an Integer word, to obtain the numerical values for the temperatures according to the corresponding table at the end of this manual. In the same way, all alarm and trip levels for each sensor can be transferred at once up to 100 sensors and two more alarm and trip levels for air temperatures, but the user should also be responsible for transforming the data from Integer words into 2 bytes in ASCII. However, we do not recommend this method due to the risk of incorrect programming and obtaining erroneous data. Note that with a single programming of parameters in a relay, the identical programming can be replicated in other relays using the memory card.



M13I-ETHERNET NTP PROTOCOL

This screen refers to the Ethernet Network Time Protocol, through which devices can obtain exact time data from previously established servers.

M13I.1 to M13I.7 - List of pre-established servers.

TESTING THE ETHERNET CONNECTION

USING A WINDOWS COMPUTER

A simplified way to test the ETHERNET connection is described below, using a simple executable software provided by Varixx (or using the **ZYGGOT Thermography Supervisory 2.00** software (see the end of this manual), also provided free of charge by Varixx, or any similar program found on the world wide web). We will consider here the explanation using the executable **pyModbusTCPV5**

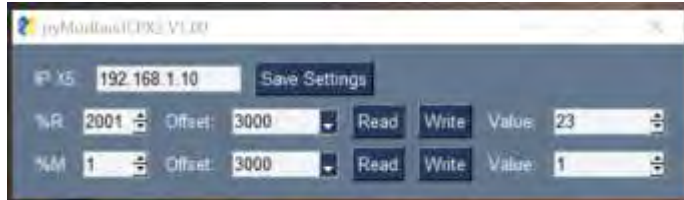

1- Initially connect the appropriate RJ45 cable between the computer and the LAN port of the Zyggot V5F/TOH relay and open Windows Settings and select the **Network and Internet** option, which will open the properties screen that will contain content as below, among others.



2- Click on the "Change adapter options" option. The following screen will open, in which an unidentified Ethernet connection should appear, in addition to the other existing connections.



3- Right-click on the unidentified Ethernet connection. The following screen will open.



4- De um duplo clique na opção **Protocolo IP Versão 4 (TCP/IPv4)**. Abrirá a seguinte tela.



4- Enter an IP address that is different from your local network, for example, if your network is **192.168.0.1** and press **OK**, you must use a network that has a different third digit. For example, we use **192.168.1.11** and in the **pyModbusTCPV5** program we use **192.168.1.10**, so the computer's address on the network will end in **11** and the Zyggot V5F/TOH relay will end in **10**. At this point, the two devices should already be connected and exchanging data. On the Zyggot relay, on the Menu screen, choose option **16. REPORT** and then the **ETHERNET REPORT / STATUS** option. Then go to screen **Er3** and activate the **START** option to test the connection with **PING**.



If the connection is OK, it will indicate a response time in the **PING RESPONSE TIME** field, which should be around **0.01 mS**. If the connection is not OK, it will indicate **PING TIMEOUT** and the **PING RESPONSE TIME** field will be all **++++++**.

If the connection is OK, open the **pyModbusTCPV5** executable program and enter the chosen address, in this example **192.168.1.10**, and click **Save Settings**. Choose a register to be read, for example **%R2001**, which will contain the target temperature of Sensor 1, plus the necessary offset according to the Modbus tables in this manual, and click **Read**. The current temperature should appear in the **Value** field. In the same way, you can read flags of the **%M** type.

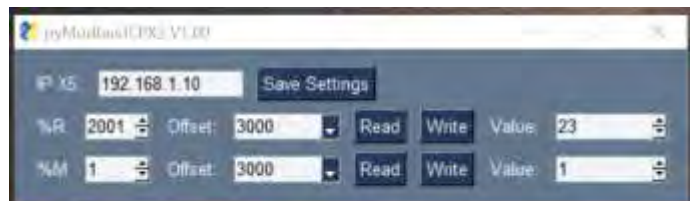

Attention: You can also write to the registers, but avoid this if you do not know that a certain register can be overwritten, as it may change the configuration parameters of the Zyggot relay.

OPERATION

IDENTIFICATION SCREEN



When energized, the relay will display the identification screen above and then perform a self-test, the result of which can be seen in the reports in the «System Data» item.

Next, if the Start of Operation has already been commanded (See next page), the relay will display the initial screen below, the first of 5 that can be paged through using the >> and << keys. These same screens can be accessed at any time from the Main Menu, using the «Esc» key. When energized, the relay will display the identification screen above and then perform a self-test, the result of which can be seen in the reports in the «System Data» item.

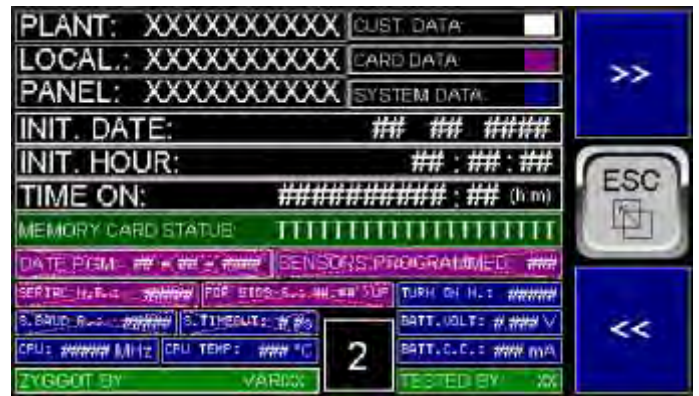

INFORMATION SCREENS



The first information screen, above, shows the system identification, embedded software version, date and time of the internal real-time clock, communication status with the S. Comm OK or S. Comm Error sensors and some indications at the bottom that are repeated on several screens to facilitate the overview of the Alarm and Trip system, namely: **FAIL**, which will be filled in red if there is an active fault, **TRGT** which will be filled in white if there is a fault related to the target temperature, **AIR**, which will be filled in white if there is a fault related to the air temperature (sensor body), **OZO** which will be filled in white if there is a fault related to the ozone level, **H** which will be filled in white if there is a fault related to the Humidity Level, **ALRM** which will be filled in yellow if there is an active alarm output and **TRIP** which will be filled in red if there is an active Trip output.



INFO screens 1 to 5 show system data and commands for inserting and removing the memory card safely, as previously described in the Main Screens section.

OPERATION

Normal Operation:

The operation is completely intuitive and can be easily learned in a matter of minutes.

It is understood that the sensors are already fully addressed by the program on the PC and correctly connected to the network as described elsewhere in this manual.

1- When the system is powered on, the start-up confirmation screen will appear only once, where the user confirms this by pressing the Proceed button, with the "Yes" option, and the Time ON counter will start.



2- After the procedure in item 1 or when the system is powered on, the main screen 1 (MS1) will appear a second time and the >> and << keys can be used to navigate through the 9 main screens (MS1 to MS9), as already described. Pressing «ESC» takes you to the Main menu (below).

Before operating or activating the system, have the parameter values and options you wish to enter in the Programming menu at hand and carry out all the programming, without permanently connecting the Alarm, Trip or Auxiliary outputs to avoid an inadvertent tripping of the system.

The first thing to do in the first operation is to check whether all the sensors are flashing correctly and responding. You can also command the «Flash» of all of them at the same time or one at a time to check addresses and whether they are active on the network. This is done using the Flash key in the Main Menu below.



3- This menu allows you to access all the system screens, in addition to the Programming Menu. Pressing «ESC» on this screen displays the first System Information screen (below) and you can navigate through the 5 screens using the keys described above, such as >> and <<. The «ESC» key returns you to the Main Menu above.



4- Pelas teclas correspondentes acesse todos as Sub telas de cada recurso e interaja ou entre com valores em cada tela, se necessário, conforme descrito na seção de Telas Principais para Operação, anteriormente.

5- Note that the «Alarm» key may or may not have a flashing red outline. If it does, press it and enter the **ALARM** screen to acknowledge and eventually clear the fault indications.

6- Note that the relay can optionally be connected to the user's DCS system via a Modbus port as described. However, this connection is not necessary for the system to be fully protected.

SCREEN FLOW - OPERATION

INFO SCREENS

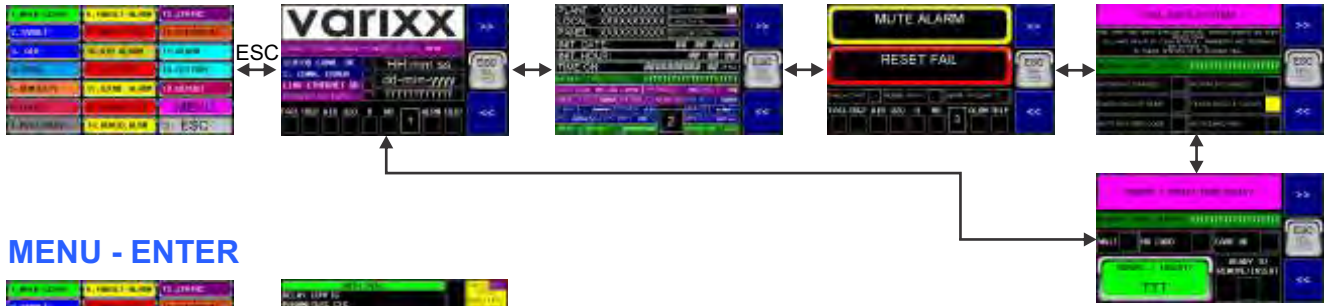

MENU - ENTER



1. MAIN SCREEN

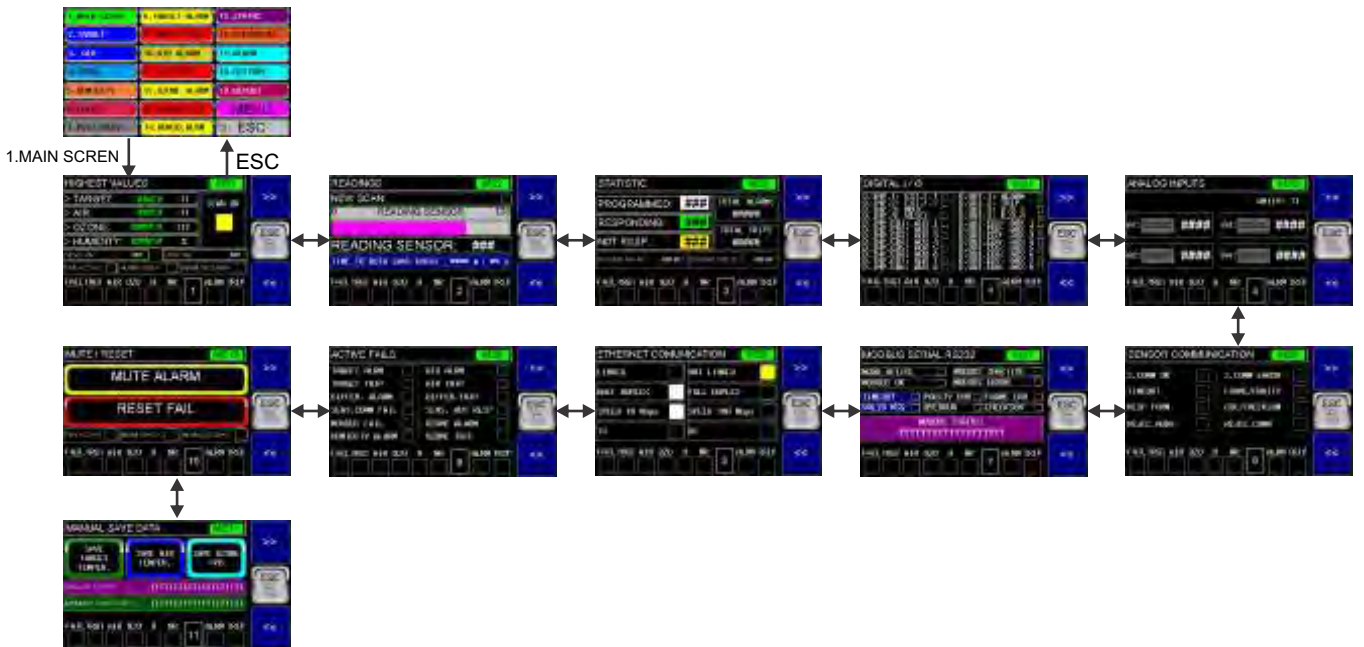

2. TARGET



SCREEN FLOW - OPERATION

3. AIR

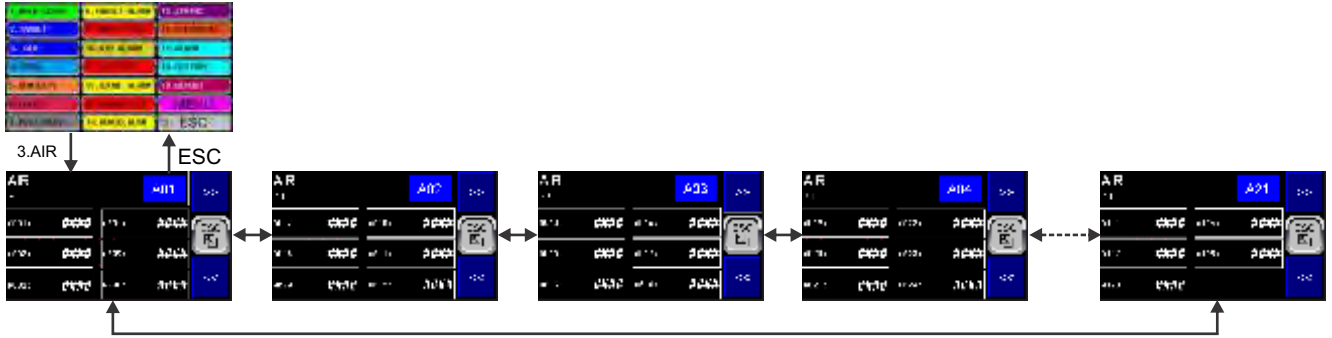

5. FAILS

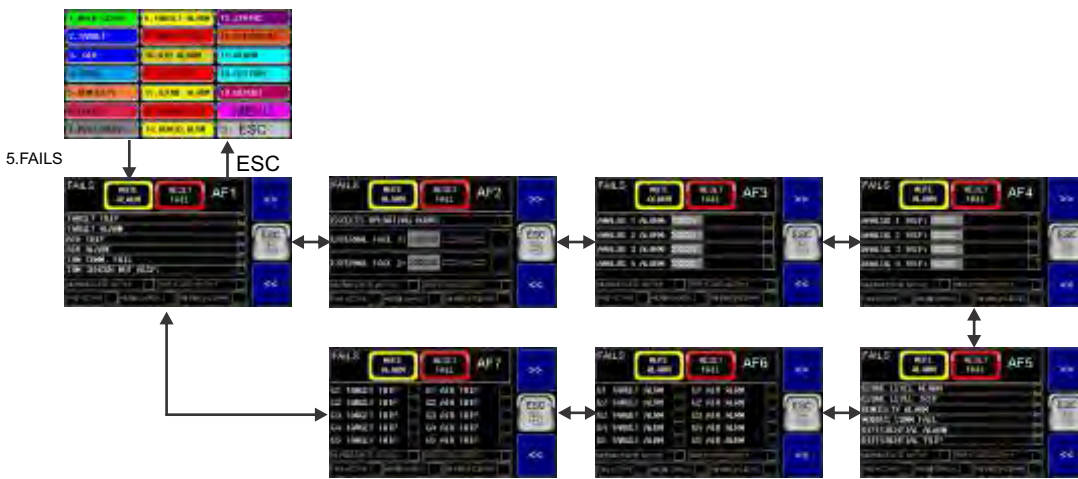

19. ALARM

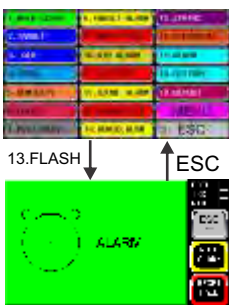

20. HISTORY

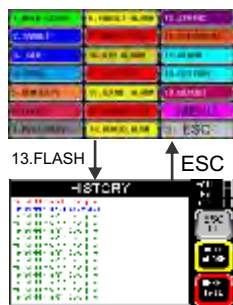

SCREEN FLOW - OPERATION

6. TRENDS

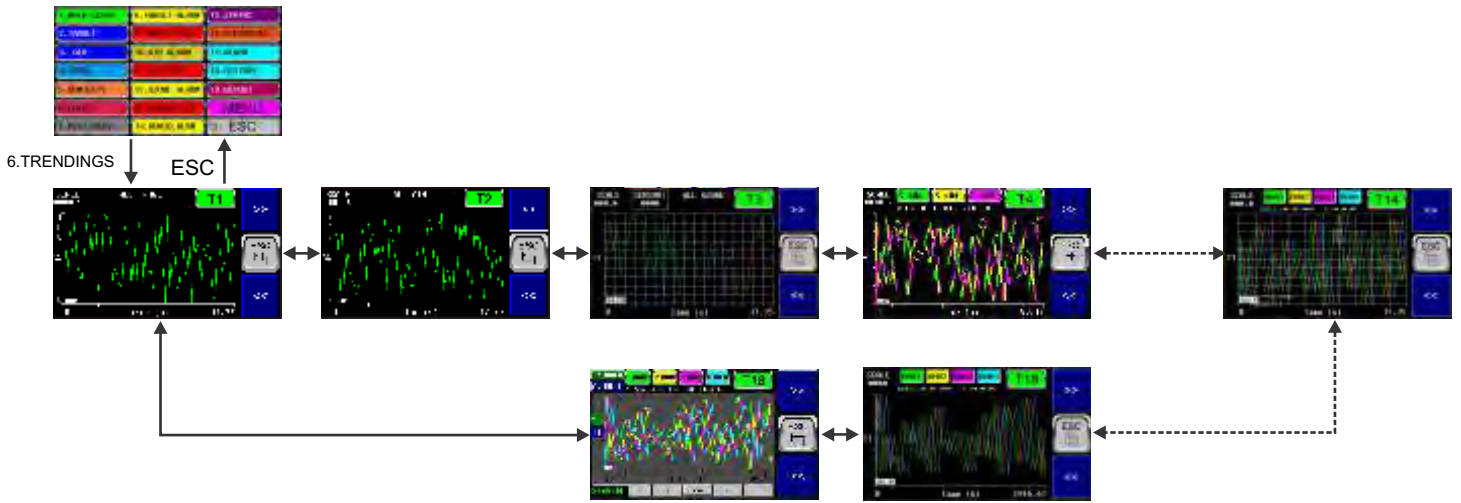

8. TARGET ALARMS

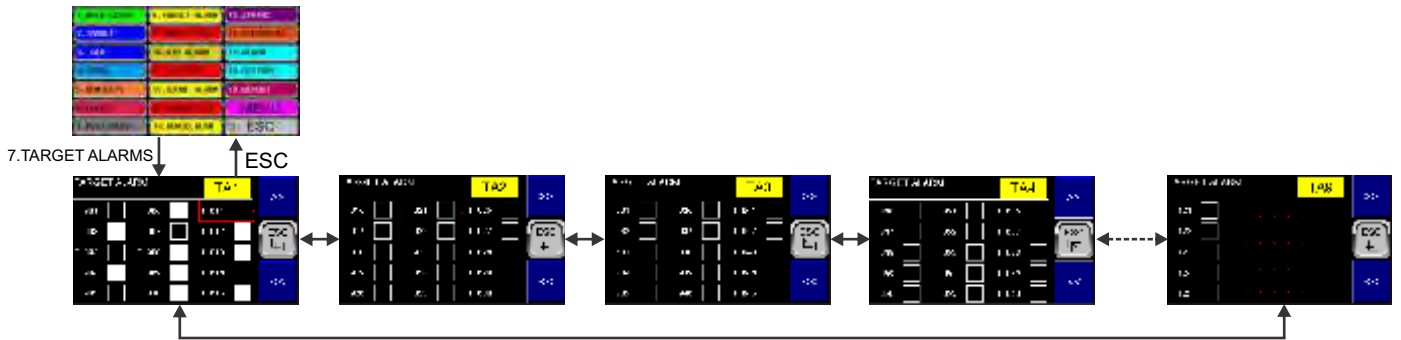

9. TARGET TRIPS

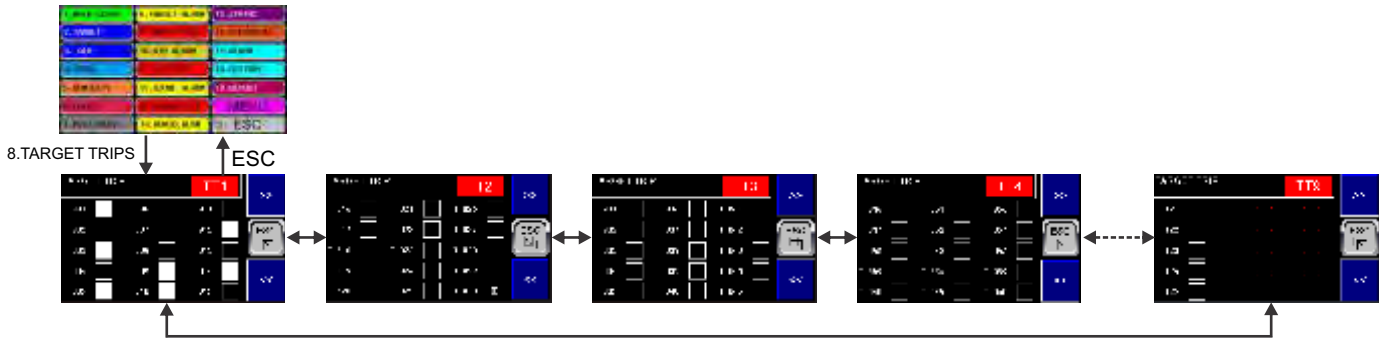

7. IDENTIFY

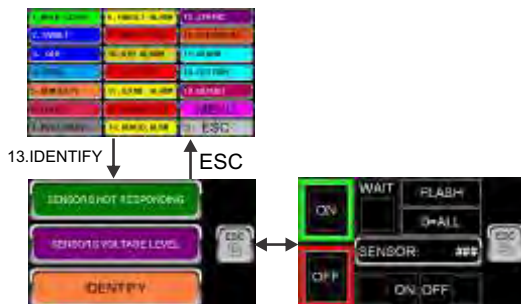

SCREEN FLOW - OPERATION

10. AIR ALARMS

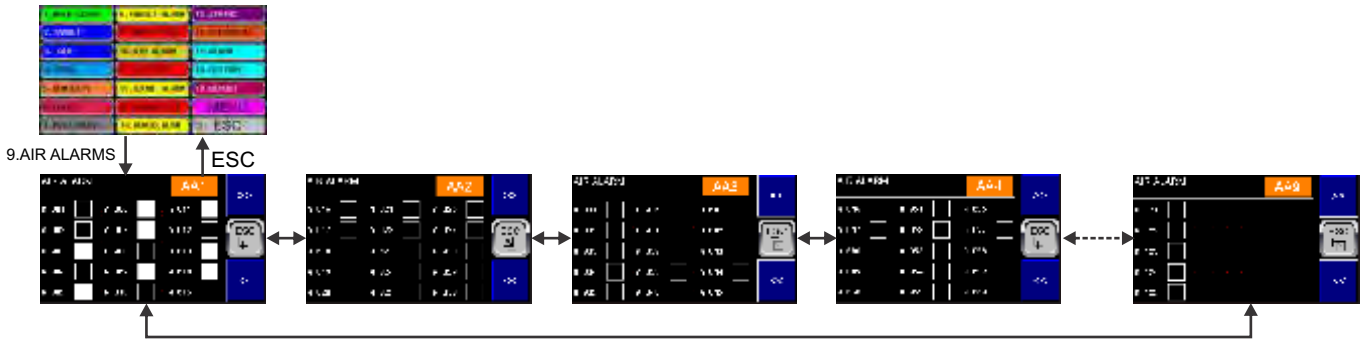

11. AIR TRIPS

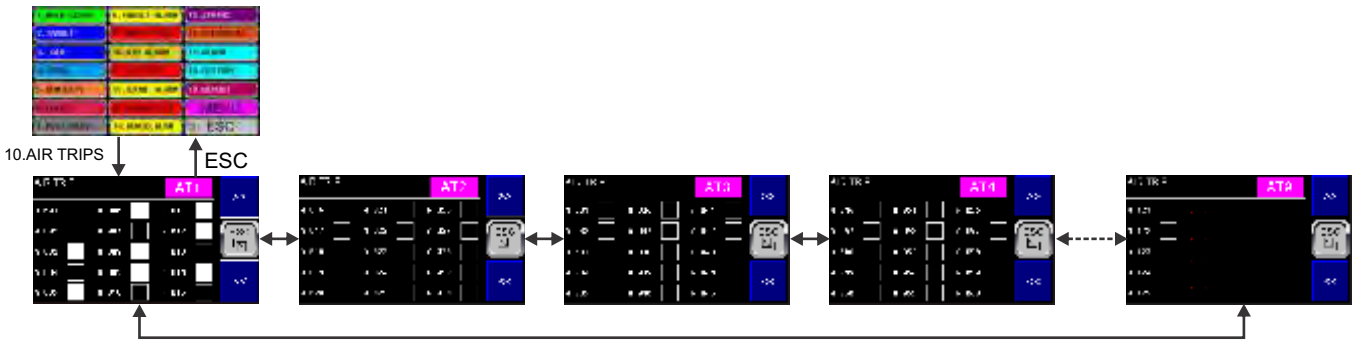

12. STATUS NOT RESPONDING THM

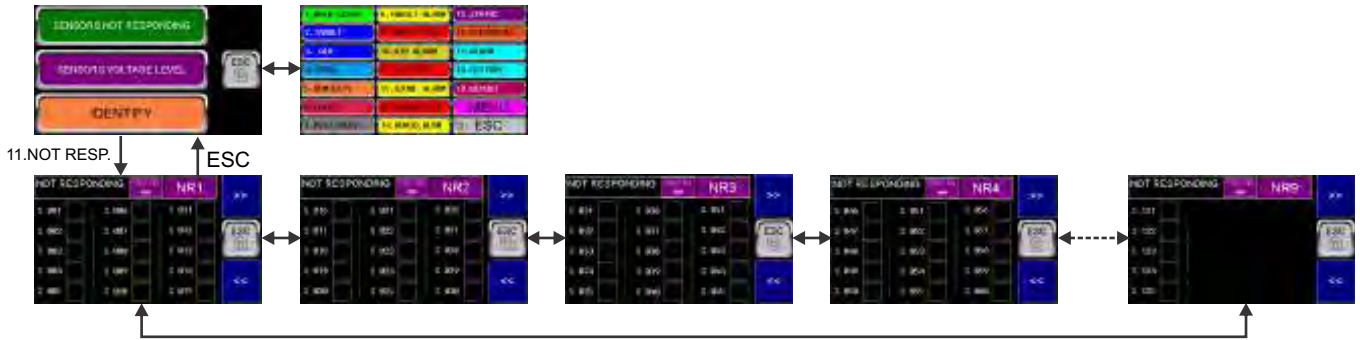

SCREEN FLOW - OPERATION

12. STATUS VOLTAGE LEVEL THM



14. DIFFERENTIAL

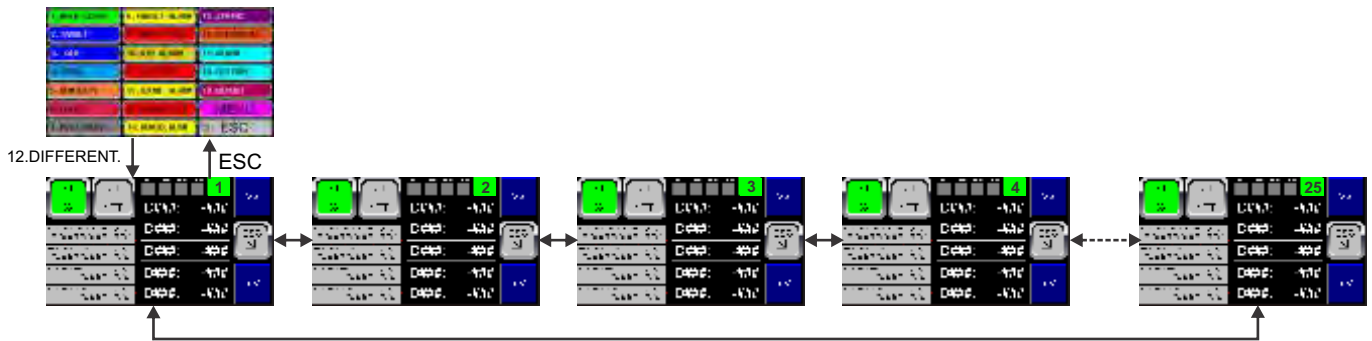

SCREEN FLOW - OPERATION

1/2 PROGRAM REPORT



ETHERNET REPORT / STATUS
(see other page)

PROGRAM REPORT

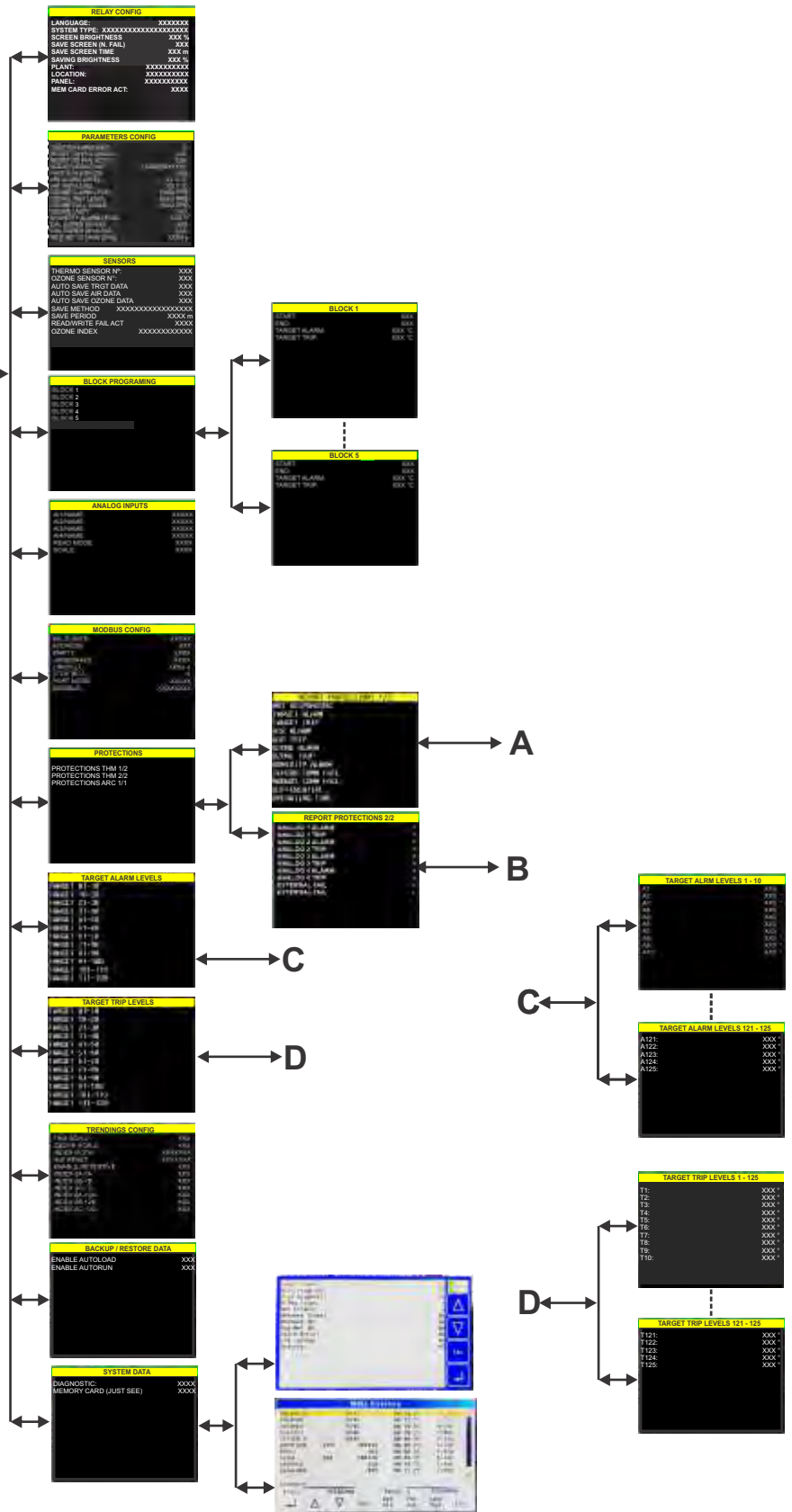

SCREEN FLOW - OPERATION

2/2 PROGRAM REPORT

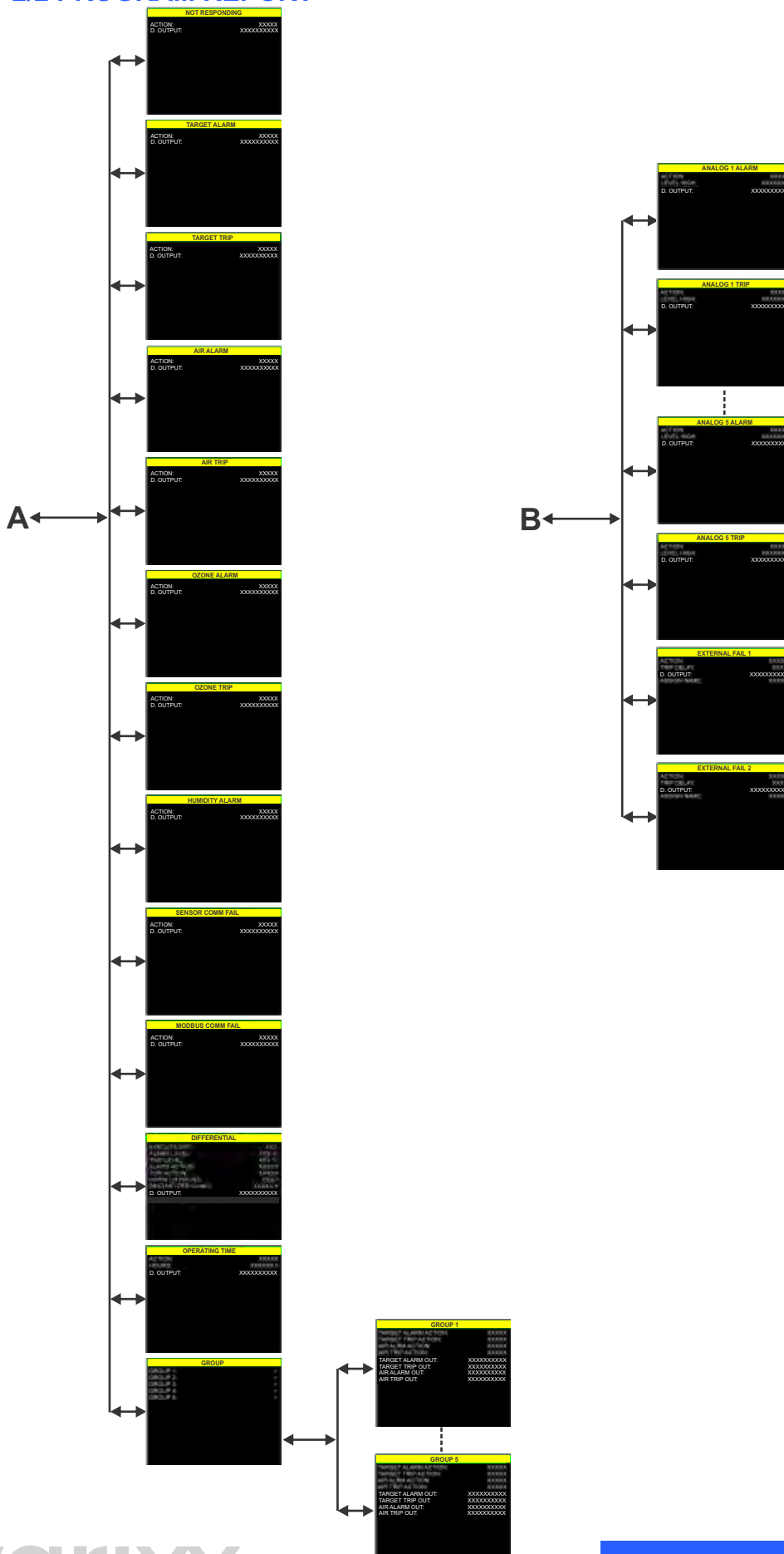

SCREEN FLOW - OPERATION

1/1 ETHERNET REPORT



SCREEN FLOW - PROGRAMMING

PROGRAMMING MENU 1/2

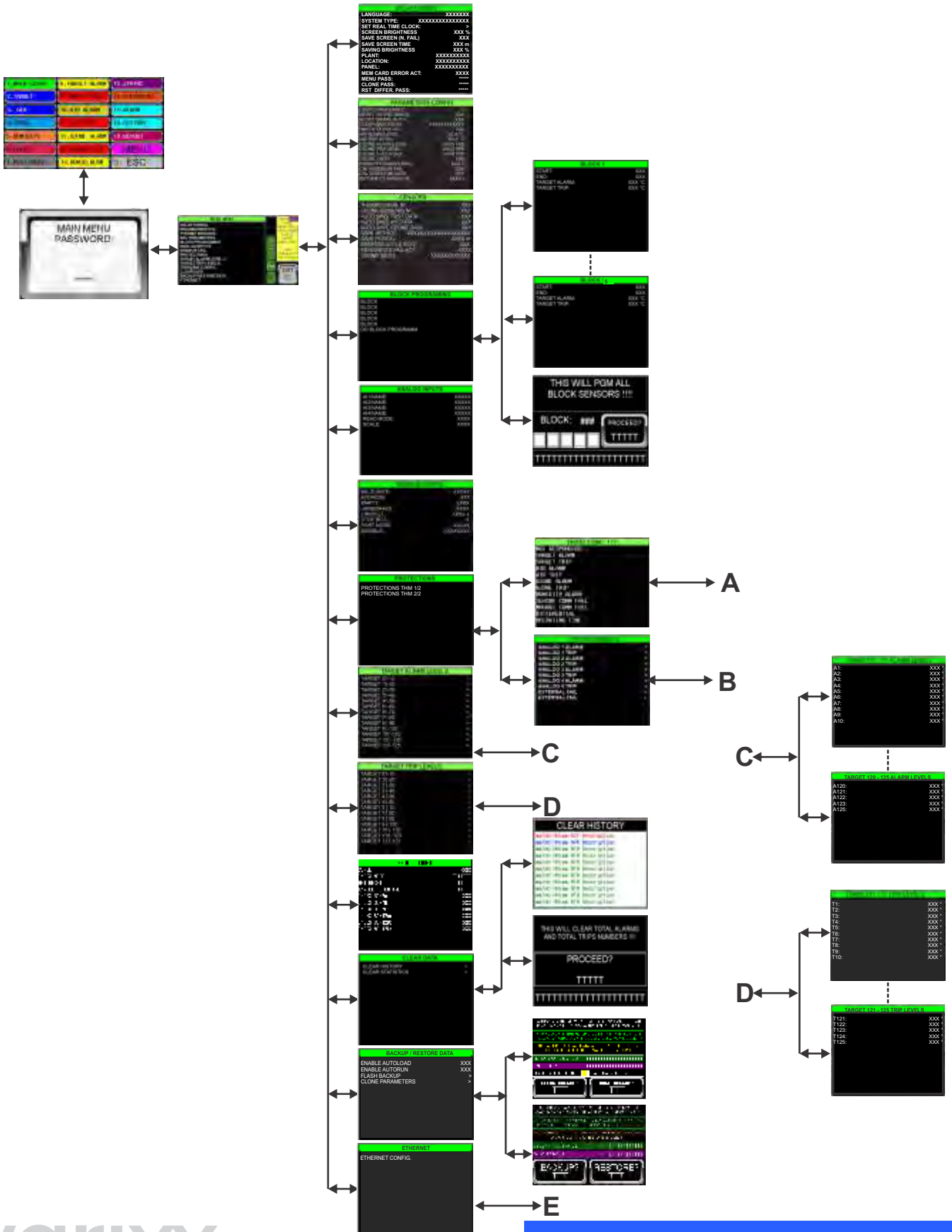

SCREEN FLOW - PROGRAMMING

PROGRAMMING MENU 2/2

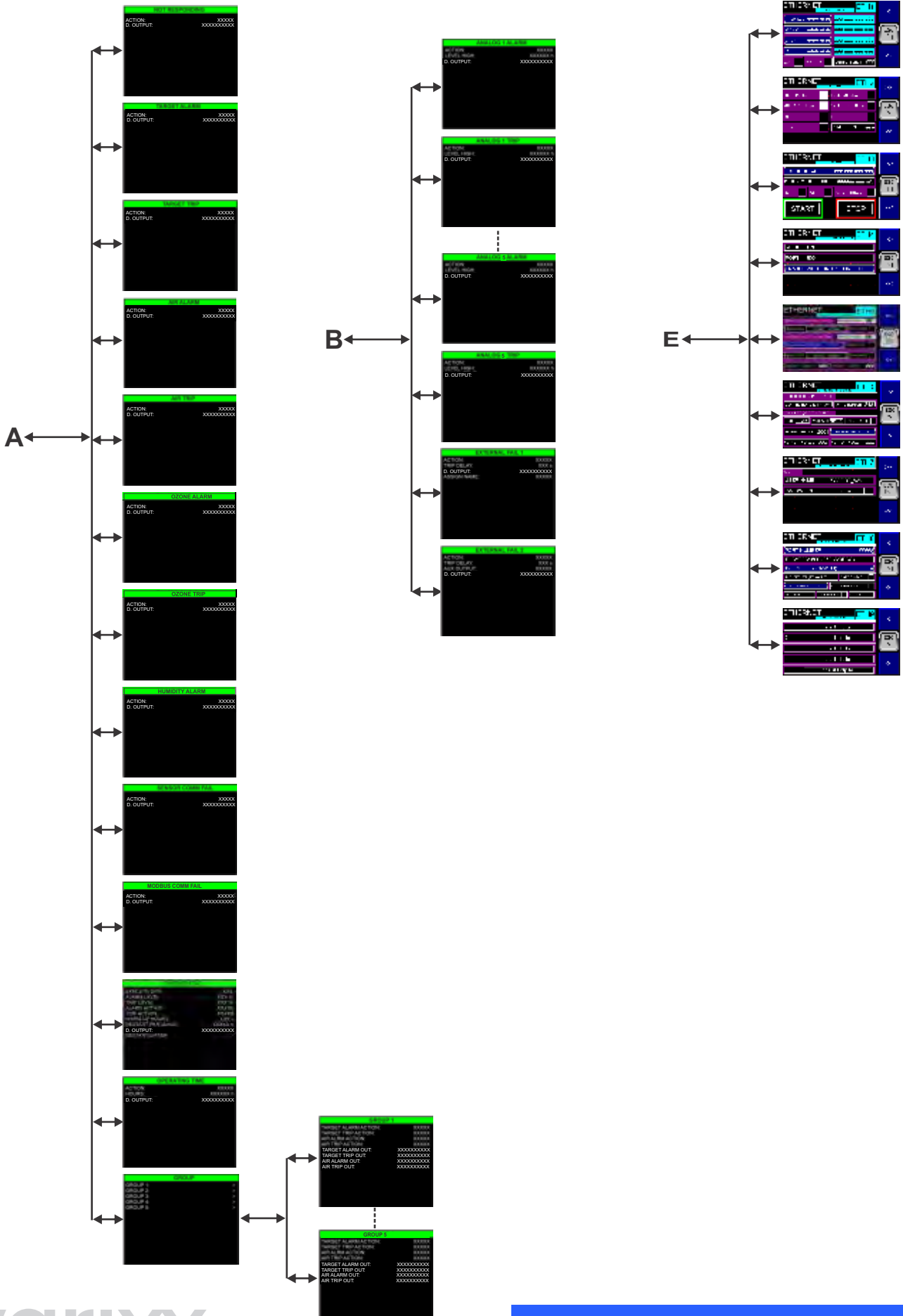

COMPUTER PARAMETERIZATION

ZYGGOT SUPERGER

Zyggot SuperGer is a configuration software for the Zyggot family. The software is available free of charge on the Varixx website (<http://www.varixx.com.br>). The main screen of the program is shown on the side.

It is possible to configure the relay directly on the relay itself and also to perform the complete programming on a relay and to clone this relay to several others using a memory card or pendrive, as explained previously. install the Superger Software on the Windows computer. All the files necessary to run it, including the «Runtime» files, are already included in the package, so no additional software is required. Once installed, it will be ready to run.



Note: With Zyggot Superger you can easily clone the parameters of one relay to another (this can also be done via the uSD card in the case of the V5F/TOH model relay). To program a series of relays with the same parameters, simply save them (using the «Save» button in the Superger Software) and load the file later if necessary so that all the parameters are ready to «Send» to the relay.

1- The first step is to connect the relay. To do so, adjust the Modbus communication values on the relay and activate it in RS-232 mode. For details on how to activate Modbus, see the programming menu section. Use an RS-232 / RJ45 cable to connect the relay to a computer. You can also use the Ethernet port and do all the programming via Ethernet communication. In this case, program the correct address as programmed on the relay in the Ethernet programming section (Modbus TCP/IP).



2- The next step in the software is to choose the language and working mode on the system configuration screen:

Once you have chosen the language, choose the Zyggot VZX or Zyggot V5F/TOH system relay. Once you have chosen the language and the type of relay, by clicking on its image, select the correct parameters for your computer (COM port 1, COM2, etc.) and the parameters that were programmed on the screen regarding Modbus in the relay (For example: Address: 1, Baudrate: 19200, Timeout: 1000 mS, Parity: None or in the case of Ethernet communication the IP Address, for example: 192.168.1.1 Make sure that Modbus is in the «Active» condition in the relay. Normally, once you have changed any parameters related to Modbus in the relay, you must turn the relay off and on for the changes to take effect, as these are parameters related to the relay BIOS.



COMPUTER PARAMETERIZATION

ZYGOT SUPERGER

3- Once the parameters are correct and the relay has Modbus enabled, click on «Connect». The «**Connected**» indicator should light up and the current parameter reading bar will indicate that the parameters are being read on the relay. This is because you can save them and also indicate in red in each parameter window that is changed that the respective parameter will be changed if you use the «**Save**» key. You can also use the «**Receive**» key at any time to read the current parameters again. The window on the right shows all the LOG messages to facilitate any communication corrections.



4- When the connection is made, the connected light will light up. If the initial reading box is checked, immediately after connecting to the relay, all the relay parameters will be transferred to the program. When finished, a success message will be displayed. Use the save and open buttons to save the information from a relay to a file on the computer and download the same information to other Zygot relays.



5- You are ready to program all parameters in the subsequent screens. Note that in each available window, when a parameter is changed, it turns red as a warning that it will be changed when sending the data to the relay.



COMPUTER PARAMETERIZATION

ZYGGOT SUPERGER



COMPUTER PARAMETERIZATION

ZYGGOT SUPERGER

6- Once the parameters are correctly programmed, they can be saved to a disk file for later use using the «**Save**» button. Previously saved files can also be loaded using the «**Receive**» button.

To send new data to the relay, use the «**Send**» button and at any time, the current relay parameters can be loaded using the «**Receive**» button.

When sending data to the relay, at the end of the transmission, a screen appears confirming that the data was transmitted successfully.



SENSOR CONFIGURATION

ZYGGOT MANAGEMENT SOFTWARE

Zyggot Manager is a configuration software that performs the addressing and testing of sensors. The software is available free of charge through the Varixx website (<http://www.varixx.com.br>) or (<http://www.varixx.com>).

Install the software on your Windows computer. All the files needed to run, including the "Runtime" files, are already included in the package, so no additional software is required. Once installed, it will be ready to run.

The program allows you to check and define important parameters before using the sensor on the network.

It defines the sensor address, the emissivity of the target considered by the sensor and the distance between the sensor and the target.

Note: When using Unidex tape (known and constant emissivity over the years), the emissivity value should be 0.95.

The user-friendly interface allows you to view the temperature of the target and the sensor body in several ways:

>> Through a graph, you can check the temperature measured over time. The scale ends can be changed with a mouse click.

>> Temperature readings are also displayed numerically.

Using an "analog" marker. The full scale value can be changed.

You can also send a command to make the sensor LED flash. Unlike when connected to the relay, the sensor remains on and does not flash when connected to the computer.

Manager Software Main Window

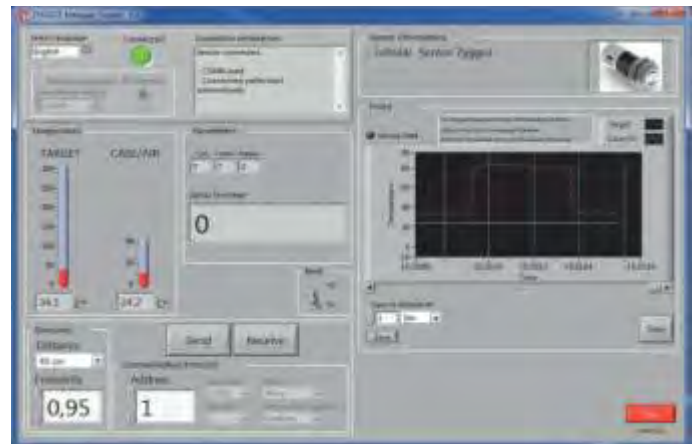

! CAUTION !

Do not connect the sensor to the PC while the other mini USB port is connected to the network.

NEVER connect two sensors to the PC simultaneously.

ALWAYS address one sensor at a time.



SENSOR CONFIGURATION

ADDRESSING SENSORS

To ensure that the system does not compromise its proper functioning, it is essential that all instructions for configuring the sensors, which will be explained below, are followed.

Each sensor must be configured before installing them mechanically.

A) Install the software on the computer and run it in sequence;

B) Connect the configuration cable (provided with the Zyggot Temperature Installation and Maintenance Case) to a USB port on the PC and to one of the sensor's mini USB ports.

Note: Unlike when the sensor is connected to the relay, the LED on the sensor body stops flashing when connected to the computer.

C) The program automatically detects the port corresponding to the sensor. If desired, it is also possible to manually select the sensor port. To do so, check the Manual Connection box, select the COM port corresponding to the sensor and press Connect. If there is no sensor connected to the selected port, an error message will appear.

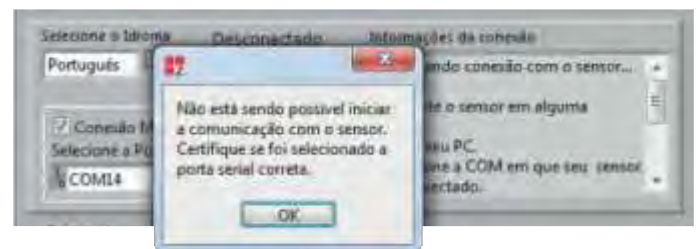
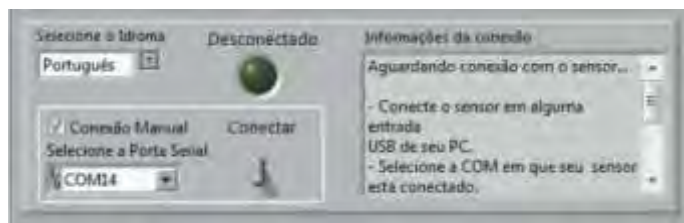
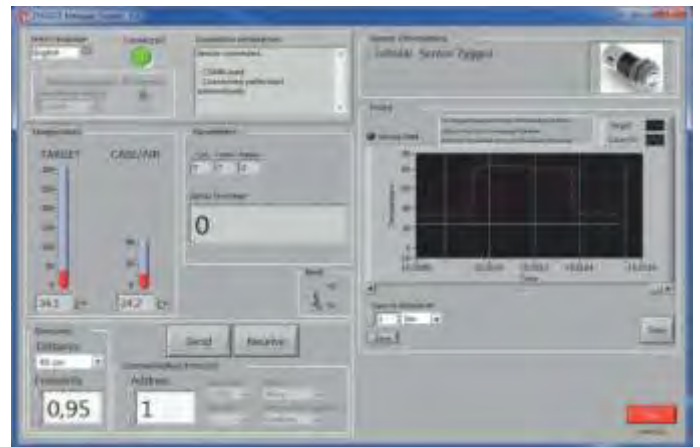

D) When connecting the sensor, the program will recognize it and indicate with a green button that it is connected.

E) Set the sensor address (1 to 100). By default, all sensors leave the factory with address 1 and correct network parameters for communication with the Zyggot Temperature relay. When finished, press the Send button.

Note: Each sensor must have a unique address on the network (from 1 to 100). When more than one sensor has the same address on the network, conflicts occur and the system will not operate.

Note: Wired sensor networks must have two termination resistors: one on the first sensor in the network and another on the last. The first of these is already integrated into the V5CON Interface. If other resistors are added to the network, the network may become unstable and may not function. Varixx provides physical termination resistors, encapsulated in a mini USB connector, for use in its sensor networks; simply insert them into the last sensor in the network.

F) Enter the target emissivity and press the Send button.

Note: When using Unidex tape (known and constant emissivity over the years), the emissivity value should be 0.95 (which is the standard emissivity value that sensors leave the factory with).

G) Enter the distance at which the sensor will be located from the target.

Note: The sensor is factory-set to a distance of 40 cm.

H) Write down the sensor address to have a map of its location on the panel or installation site. This is the address that will be shown on the relay screen for this sensor, for its correct identification.

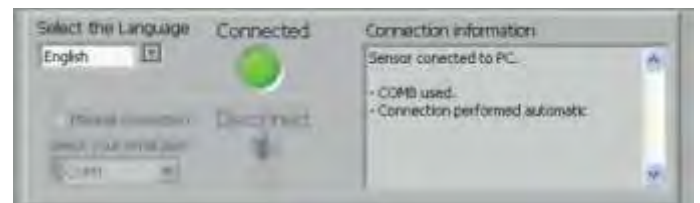

FAIL SAFE SYSTEM

The Fail Safe System is a feature that allows the Zyggot relay to continue operating in the event of certain types of "soft" failures. These "soft" failures include:

- Loss of backup battery power.
- Corruption of the register RAM, or corruption of the firmware Flash due to, for example, an excessive EMI event.

Nome	Data de modificação	Tipo	Tamanho
■ PLOTZ21	17/08/2021 09:09	Pasta de arquivos	
■ DATANEW	18/08/2021 16:53	Pasta de arquivos	
■ DATAMAN	17/08/2021 16:27	Pasta de arquivos	
■ DATAAUTO	17/08/2021 10:38	Pasta de arquivos	
■ DEFAULT.PGM	09/08/2021 18:32	Arquivo PGM	482 KB
■ AUTOLOAD.PGM	09/08/2021 18:33	Arquivo PGM	482 KB
■ CLONE.DAT	09/08/2021 18:33	Arquivo DAT	107 KB
■ DATACARD	17/08/2021 19:06	Arquivo	1 KB
■ DATABCK	18/08/2021 09:51	Arquivo	1 KB
■ BACKZ	06/08/2021 17:47	Arquivo	1 KB

The Fail Safe System must have a file structure on the Memory Card similar to the one shown in the screen above.

Attention: With the exception of files within directories, which can be freely changed or deleted, files in the root directories cannot be modified or deleted, as this will interrupt the relay's operation.

The failsafe system encompasses the following features:

- Manually back up current registry settings from battery-backed RAM to Flash memory.
- Manually restore registry settings from previously saved values in Flash to battery-backed RAM.
- Detect corrupted registry settings at boot and then automatically restore them from Flash memory.
- Detect corrupted or empty Firmware in Flash memory at boot and then automatically load the AUTOLOAD.PGM file from removable media (CompactFlash / microSD).
- If an automatic registry restore or application load occurs, Zyggot V5F/TOH will automatically be put into RUN mode.

HOW TO DO...

COMO PROGRAMAR O RELÉ.

There are three ways: Using the HMI itself, or using the free PC configuration program, or using the **Backup/Clone** function from a memory card. To use the PC program, see the specific manual.

To program using the HMI:

Press **«Menu»**, enter the correct password and follow the user-friendly submenus.

If the programming password is Zero, you will enter the menu directly; if it is different from zero, a screen will appear asking for the password. Enter it and press ENTER

You can change this password in the **Param. Config. menu**. The factory password is 1.

To program using the PC software, see the specific manual for the software.

To clone data using a memory card, use option **12. Backup/Clone** in the Main menu.

Backup the data of a previously programmed relay using the **«Backup»** function

HOW TO CHOOSE THE LANGUAGE.

For the screens and menus, the relay is available in 3 languages: English, Portuguese and Spanish. Any fourth language can be requested at the time of purchase (Custom) by prior agreement with the manufacturer.

To select the language:

Enter the Menu, Relay Configuration Submenu, Select the Language item,

Press Enter,

Select the required language by pressing Enter again to confirm and ESC to exit the menu.

! HOW TO CONFIGURE SENSORS (“SENSOR” MENU)

! Enter the **Programming Menu** and then the **Sensors** submenu.

Choose the item to change and press **ENTER**, Choose the option from the list of each parameter or enter the data if it is numeric,

Press **ENTER** to confirm,

Choose the next item and repeat the operation.

HOW TO CHANGE THE PROGRAMMING PASSWORD (“RELAY CONFIG” MENU).

! Enter the **Main Menu** and then the Relay Config submenu.

! Choose the item to change and press ENTER.

! **Menu Pass:** Enter the new password if you wish to change it. The factory password is **827499**. If you enter “0” as the new password, you can enter the Menu without a password by simply pressing the Menu key.

! Press **ENTER** to confirm.

HOW TO NAME THE PLANT, LOCATION AND PANEL AND ENTER THE START DATE OF OPERATION.

For information purposes, the above items can be named with up to 5 characters. Proceed as follows:

Enter Menu, **Relay Config Submenu**,

Select the desired item,

Press **Enter**, Enter the new data using the numeric keys, press **Enter** to confirm and **ESC** to exit the menu.

HOW TO CHECK SENSORS NOT RESPONDING.

To view the map of non-responsive sensors, press 15.STATUS and then **«SENSOR NOT RESPONDING»** to call up the **NR1** screen and use the arrows to view all **NR** screens if necessary. Non-responsive sensors will have purple squares.

If there is no response during a reading attempt, the indication on the main screen will be activated and all indicators of non-responsive sensors on screens **NR1** to **NR9** will be activated, since there was no response. In this case, all temperature readings will be indicated with 8888, as invalid. In this case, there will be no trip or alarm due to temperature, but only due to Not Responding if it is enabled.

HOW TO SET THE REAL TIME CLOCK.

If necessary, due to daylight saving time or other reason, proceed as follows:

Enter **Menu, Relay Config Submenu**,

Select the **Set Real Time Clock** item,

Press **Enter**, Enter the new data, using the small arrows below the display, press **Enter** to confirm and **ESC** to exit the menu.

HOW TO SET PARAMETERS (“PARAMETERS” MENU).

! Enter the Main Menu and then the **Config Parameters** submenu.

! Choose the item to change and press **ENTER**,

! Choose the option in the list for each parameter or enter the data if it is numeric,

! Press **ENTER** to confirm,

! Choose the next item and repeat the operation.

HOW TO CONFIGURE MODBUS COMMUNICATION. (“MODBUS” MENU).

The names for this menu are the classic ones and there is nothing to explain, since the user must know the protocol to use Modbus communication. The port for Modbus communication is RJ1.

Enter the **Programming Menu** and then the **Modbus CFG** submenu.

Choose the item to change and press **ENTER**

Choose the option from the list for each parameter or enter the data if it is numeric.

Press **ENTER** to confirm.

Choose the next item and repeat the operation.

The parameters are as follows:

Baud Rate, Address, Parity, Handshake, Timeout, Port Mode (RS232 or RS 245), Stop Bits and Modbus (Active, Inactive)

HOW TO CONFIGURE THE CURVES (DATA PLOT). (MENU "DATA PLOT CONFIG").

The curves related to temperatures and analog inputs must be configured in this menu.

* Enter the **Main Menu** and then the **Data Plot Config** submenu.

* Choose the item to change and press **ENTER**.

* Choose the option in the list for each parameter or enter the data if it is numeric or alphanumeric.

* Press **ENTER** to confirm.

* Choose the next item and repeat the operation. The parameters are as follows:

* **Scale:** Enter the scale to be used for all curves.

* **Index Mode:** (Display, Menu). If Display is selected, the operator must enter the indexes of each curve directly on the curve screens as explained in the Operation chapter. If Menu is selected, the indexes used will be those entered below.

* **HMI Reset:** (No, Yes). Enables or disables the operator's ability to reset or restart each curve using the ESC command (to do this, hold down the ESC key for 3 seconds and the curve will restart).

* **Index 1A-5A to Index 6C-10C.** (1 to 129): enter the sensor numbers from 1 to 125. These are the signals that will be used in the corresponding curves if Menu mode is selected in Index Mode. The curves of indexes 1 to 5 (A, B and C, i.e. three curves per trending screen) will be shown on trending screens 3 to 7 and the curves of indexes 6 to 10 will be shown on screens 8 to 12. Note: indexes 126 to 129 are used to address analog inputs 1 to 4.

For the T19 screen, which is retentive and can save the time and date curves in Excel format on the memory card, select the Enable Retentive item and choose «**Yes**».

See more details in the Programming chapter.

HOW TO DEFINE EMISSIVITIES FOR EACH TARGET. (MENU "SENSOR").

The emissivity indices for each target can be defined in the programming of the sensor itself, where the emissivity and the sensor address are entered, using the free PC program available on our website. See specific manual for the sensor programming software.

HOW TO SET ALARM LEVELS FOR TARGET OVERTEMPERATURE. (MENU "TARGET ALRM LEVELS").

Target alarm levels can be defined in block programming, as explained above. A single group with all sensors can be programmed if the level is the same for all or up to 5 different levels, one for each block. Another way, even after programming by blocks and if you want to individually change some or all of the levels, is through the "Alrm Target Levels" menu.

Enter the Main Menu and then the Alrm Target Levels submenu.

A menu with 13 submenus is displayed, each containing up to 10 levels.

Select the level to change and enter the value.

Press **ENTER** to confirm,

Choose the next item and repeat the operation.

HOW TO CONFIGURE ANALOG INPUTS. (MENU "ANALOG INPUT").

For the analog inputs, you can enter the name of each one (5 characters), facilitating the identification, choosing the reading mode and the scale.

Enter the **Main Menu** and then the Input submenu **Analog Inputs**.

Choose the item to change and press **ENTER**,

Choose the option from the list of each parameter or enter the data if it is numerical or alphanumeric.

Press **ENTER** to confirm,

Choose the next item and repeat the operation.

HOW TO SET ALARM LEVELS FOR TARGET OVERTEMPERATURE. (MENU "TRIP TARGETED LEVELS").

Target tripping levels can be defined in block programming, as explained above. A single group with all sensors can be programmed if the level is the same for all or up to 5 different levels, one for each block. Another way, even after programming by blocks and if you want to individually change some or all of the levels, is via the "Target Trip Levels" menu.

Enter the Main Menu and then the Trip Target Levels submenu.

A menu with 13 submenus is displayed, each containing up to 10 levels.

Select the level to change and enter the value.

Press **ENTER** to confirm,

Choose the next item and repeat the operation.

HOW TO DEFINE THE ACTIONS AND AUXILIARY RELAYS ACTIVATED FOR EACH PROTECTION. (MENU "PROTECTIONS").

The action to be taken, which can be: Nothing (disables the protection), Log (the event is entered in the history and alarms list but no output relay is activated (not even the Alarm relay or the Trip relay), Alarm (the Alarm output relay is activated) and Trip (the "Alarm" and "Trip" outputs are activated).

There are 2 protection submenus: Protections 1/2 and Protections 2/2.

The first contains the general protections, the second the protections referring to analog inputs and external faults.

Enter the Main Menu and then the Protections submenu.

A menu with 3 submenus is displayed.

Select one of them and press **ENTER**.

Select the protection sub-item to be programmed and press **ENTER**,

Select the action and auxiliary relay.

SUPERVISORY SOFTWARE

ZYGGOT THERMOGRAPHY 2.0 SUPERVISORY SOFTWARE

Zyggot Supervisory - **Version 3.10** and higher, is a program that communicates with the relay and presents sensor readings on the computer screen just like a supervisory system. The software is available free of charge through the Varixx website (<http://www.varixx.com.br>). Install the Software on your Windows computer. All files needed to run, including "Runtime" files, are already included in the package, meaning no additional software is required. Once installed it will be ready to run.

2- The first step is to press the **Configure Modbus** button. You can see the initial screen "**Configure Modbus**". Once you have chosen the connection mode, namely a) **Modbus RTU (Serial)** or b) **Modbus TCP (Ethernet)** (in the top selection box, under the phrase «Select the communication medium») and entered the parameters corresponding to those entered in the relay you can click on the «Connect» button and if the connection occurs, the «Connected» flag will turn from red to green.

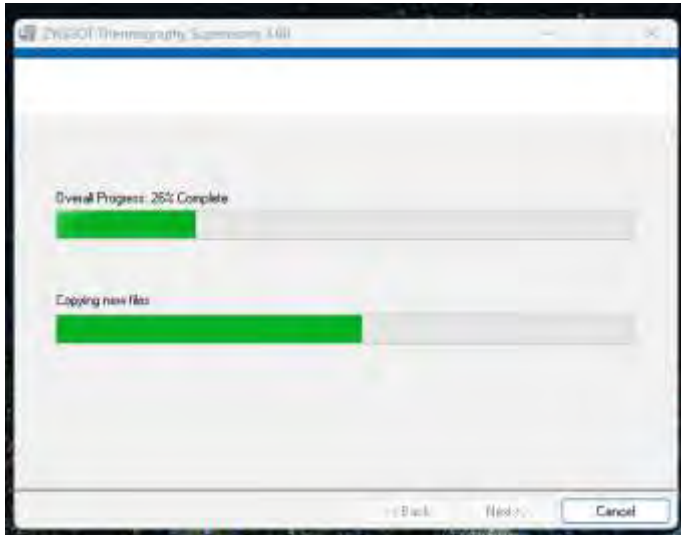

1- The first step is to connect to the relay. To do so, adjust the Modbus communication values on the relay and activate it in RS-232 mode. For details on how to activate Modbus see the programming menu section. Use an RS-232 / RJ45 cable to connect the relay and a computer. You can also use the Ethernet port and do all programming via Ethernet communication. In this case, program the correct address as programmed in the relay in the Ethernet programming part (Modbus TCP/IP). Use an Ethernet cable in this mode.

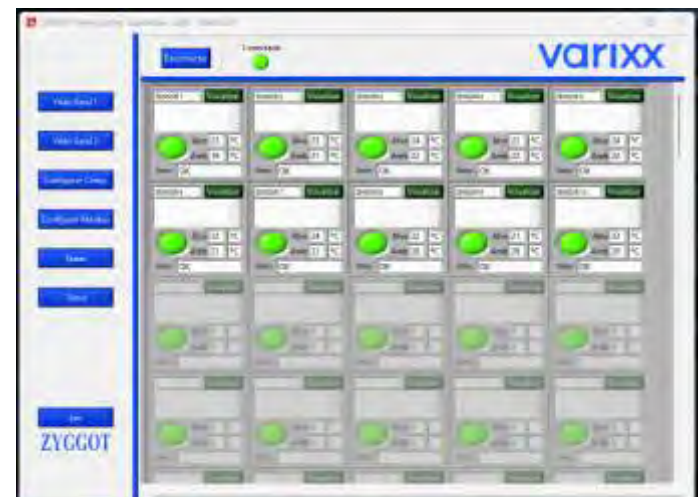
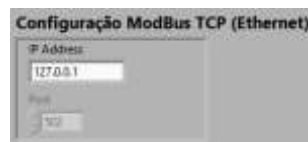

Note: This software is not required for system operation. It is a bonus that the user can use to check the system or not.



SUPERVISORY SOFTWARE

ZYGGOT THERMOGRAPHY 2.0 SUPERVISORY SOFTWARE

3- Once connected, click on the «**Overview 1**» button, you can observe the target and air temperatures (sensor body) of each sensor responding on the network and a description of the same case inserted.

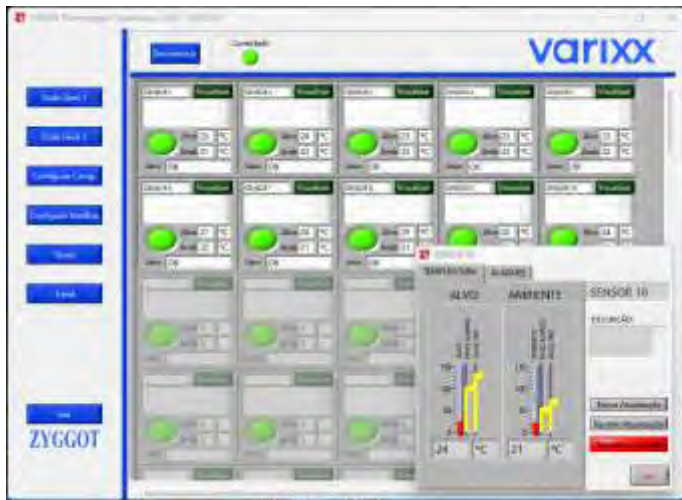

4- Click on the «**View**» button or on the lens symbol for each of the sensors. A window opens with alarm adjustment sliders and Alarm and Trip level parameters, which can be adjusted using the mouse and sent to the relay by clicking the “Send update” button. Note that when changing the slide its color changes from blue to yellow until «**Update**» is commanded. This function is also used to test the operation of the Alarm or Trip by adjusting levels below the current reading levels indicated in red. By clicking on the «**Alarms**» tab in this window for each sensor, you can also change the Alarm and Trip levels through the corresponding windows, using the mouse or by entering the values using the keyboard. Note that the color of the window changes to red until the “Send update” command is made. This way you can change relay parameters in real time.

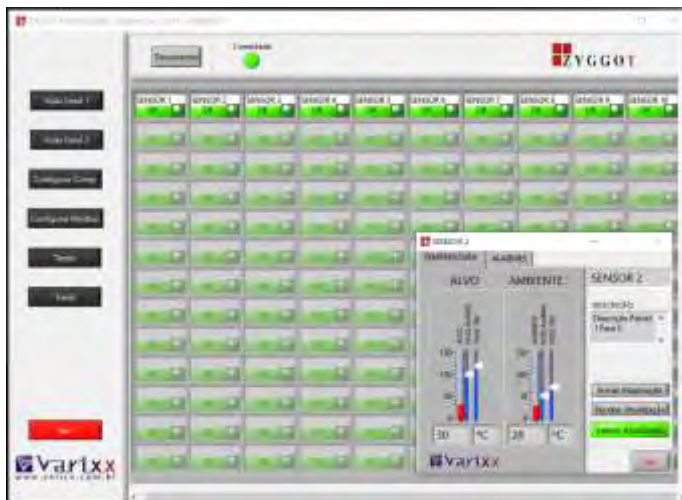

5- Click on the «**Configure Comp**» button in the menu on the left and the following screen opens with 3 options, namely «**Sensors**», «**Thermometers**» and «**Alarm Levels**»

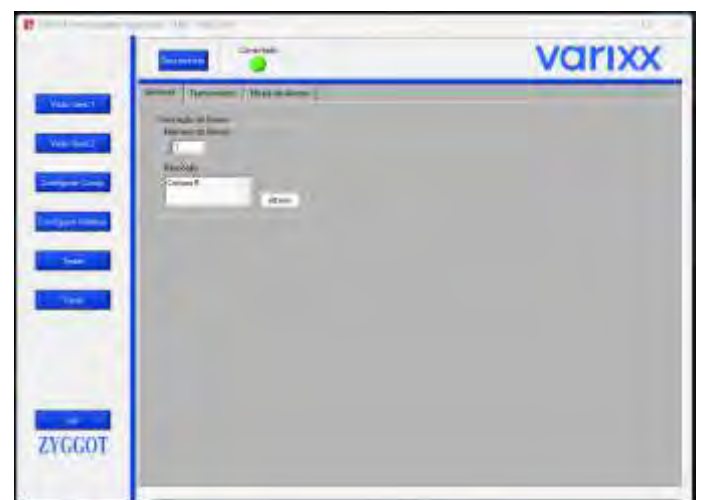

6- Click on the «**Sensors**» tab and you can enter a description of each of the sensors, for example «**Column R**» etc. Click on the Thermometers tab and you can change the scales of each thermometer on the graph. Click on the «**Alarm Levels**» tab and you can change the waiting time to be notified of a change in level.



7- Click on the «**Test**» tab and you can change the LED blinking mode on each sensor, from blinking to continuous or vice versa to locate it on the panel or to test whether it is responding correctly on the network. Zero commands the change in all sensors.



SUPERVISORY SOFTWARE

ZYGGOT THERMOGRAPHY 2.0 SUPERVISORY SOFTWARE

8- Click on the «Trend» button and you can see the screen on which you can plot the Target and Air temperatures of up to 10 sensors simultaneously.

Through the corresponding windows you can choose the sensors to be plotted, whether **Target** and/or **Air** and the trace color of each one. To change the color, click on the small colored square for each stroke and choose the new color.

In the lower window on the left side you can choose the period for automatic saving of readings in a CSV file which can be opened in Excel.

You can also command manual saving at any time using the “Save” key. Using the “Save” button, you can save the data read so far in Excel CSV format for later documentation, and you can even generate the corresponding graphs. Once clicked on save a window to choose the destination and file name will appear.

In the last figure, below, you can see an example file, with 5 sensors and Target and Air temperatures for each of the readings.

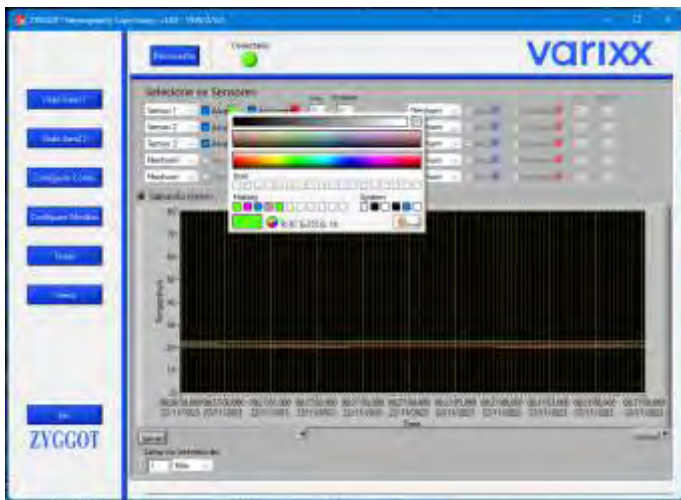
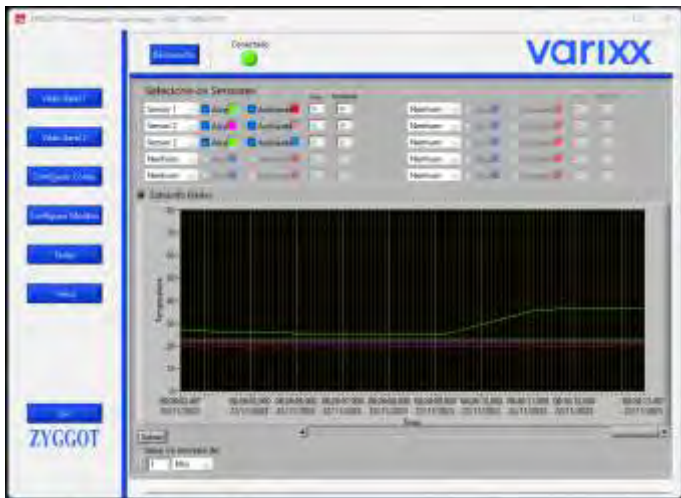

The screenshot shows an Excel spreadsheet with a CSV file containing sensor data. The data is organized into columns for time and five different sensors (Amb 1 to Amb 5).

	Amb 1	Amb 2	Amb 3	Amb 4	Amb 5
08:28:55	21	22	23	20	21
08:29:55	21	22	23	20	21
08:30:59	22	22	23	19	21
08:32:02	25	48	33	30	21

ASCII OVER TCP/IP DATA TABLE

ASCII OVER TCP/IP PROTOCOL



DATA Received 500 bytes (8 Bits) (250 Words 16 bits)

ASCII: 8Bits

This data can be used to set the Alarm and Trip levels independently for each of the 125 sensors.

To copy the received data to the corresponding parameters after successful reception, the %M99 Flag or the Byte T (Bytes 3 and 4) must be set, depending on what is selected in the «Copy Trigger» parameter on the ETH8 screen (options **Byte T** (Byte Termination) and Flag %M99).

To start the transmission, the %M100 flag must be set on the corresponding screen either through the normal TCP/IP protocol or through serial communication with Modbus.

Note that to set the %M100 flag it will be necessary to do so through the TCP/IP (Modbus Over Ethernet) protocol. The only advantage of using the ASCII OVER TCP/IP protocol, as described here, is to transmit all the data at once, but for security reasons, it should be avoided. In addition, the user will have to convert two bytes into 1 word to obtain the values.

Note that through the TCP/IP (Modbus Over Ethernet) protocol the same data can be read normally.

NOTE: This protocol is described here because it can optionally be used but always prefer to use Modbus in a serial connection directly or Modbus Over Ethernet TCP IP discussed below and much more practical and direct.

After copying the Records, if Copy Enabled, these Bytes (Byte 3 and Byte 4) return to zero automatically (See details in the respective chapter in this manual).

Note that to set the %M99 Flag it will be necessary to do so via the TCP/IP protocol (Modbus Over Ethernet) or via serial communication with Modbus.

In the ASCII OVER TCP/IP protocol, as described here, all data is transmitted at once. For safety reasons, this method should be avoided. Furthermore, the user will have to convert two Bytes into 1 Word to obtain the values.

Prefer to use **Modbus Over Ethernet** directly, according to the Modbus tables in this Manual or programming directly on the Zygote Relay screen or programming by transferring data from the Memory Card when programming more than one relay with the same parameters.

Note that the same data can be written normally using the TCP/IP Protocol (Modbus Over Ethernet).

DATA TRANSMITTED 500 bytes (8 Bits) (250 Words 16 bits)

ASCII: 8Bits

Note: as 500 Bytes (8 Bits) are transmitted, which is equivalent to 250 Words (16 Bits), the user must convert 2 Bytes into a word to obtain the transmitted data.

Byte 1 = Set to 500 (indicates the number of Bytes to be transmitted).

Byte 2 = Byte T = 0 or 1 - Set to 1 if the Byte T (Byte Termination) option is selected in the «Copy Trigger» parameter and not Flag %M99.

After copying the Records, if it is allowed (Copy Enabled), this Byte returns to zero automatically (See details in the respective chapter in this manual).

Byte 3 = LSB Temp. target or Ozone of Sensor 1

Byte 4 = MSB Temp. target or Ozone of Sensor 1

Byte 5 = LSB Temp. target or Ozone of Sensor 2

Byte 6 = MSB Temp. target or Ozone of Sensor 2

====

Byte 252 = LSB Temp. target or O³ of Sensor 125

Byte 253 = MSB Temp. target or O³ from Sensor 125

Byte 254 = LSB Air Temp. or Humidity Sensor 1

Byte 255 = MSB Air Temp. or Humidity Sensor 1

====

Byte 499 = LSB Air Temp. or Humidity Sensor 124

Byte 500 = MSB Air Temp. or Humidity Sensor 124

Note: Air Temp. or Humidity data from sensor 125 cannot be obtained with this reading method.

Note: since 506 Bytes (8 Bits) will be received, which is equivalent to 253 Words (16 Bits), the user must convert a word (16 Bits) into 2 Bytes (8 Bits) before transmitting the data.

Byte 1 = LSB Alarm Level Sensor 1

Byte 2 = MSB Alarm Level Sensor 1

Byte 3 = LSB Alarm Level Sensor 2

Byte 4 = MSB Alarm Level Sensor 2

====

Byte 199 = LSB Alarm Level Sensor 125

Byte 200 = MSB Alarm Lvl Sensor 125

Byte 201 = LSB Trip Level Sensor 1

Byte 202 = MSB Trip Level Sensor 1

====

Byte 499 = LSB Trip Level Sensor 125

Byte 500 = MSB Trip Level Sensor 125

MODBUS

A complete explanation of the Modbus RTU or ASCII protocol is not within the scope of this manual. It is assumed that the user who will apply the same using this protocol, must have sufficient knowledge for this.

Also, in this manual we will only provide the basic addresses of the memory map to perform the usual operations of reading faults and others. Any parameter programming must be performed on the device itself, as it is normally done only once, during Startup.

Next, there will be a short introduction to the Modbus communication network before the memory map presentation.

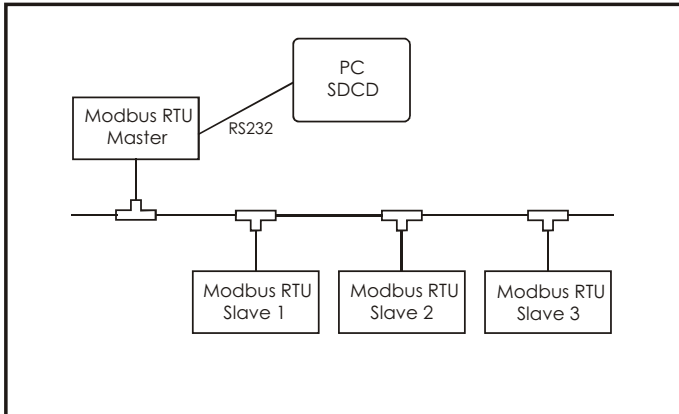

Devices communicate using a master-slave technique, in which only one device (the master) can initiate transactions (called 'queries'). The other devices (the slaves) respond by supplying the requested data to the master, or by taking the action requested in the query. Typical master devices include host processors and programming panels. Typical slaves include programmable controllers, motor controllers, load monitors etc, see Fig

The master can address individual slaves. Slaves return a message (called a 'response') to queries that are addressed to them individually. The Modbus protocol establishes the format for the master's query by placing into it the device address, a function code defining the requested action, any data to be sent, and an error checking field. The slave's response message is also constructed using Modbus protocol. It contains fields confirming the action taken, any data to be returned and an error-checking field. If an error occurred in receiving the message, or if the slave is unable to perform the requested action, the slave will construct an error message and send this as its response, see Fig.

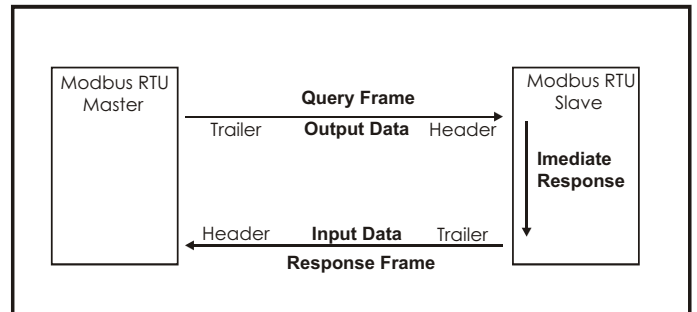

Address field

The address field of a message frame contains eight bits. The individual slave devices are assigned addresses in the range of 1 - 247. A master addresses a slave by placing the slave address in the address field of the message.

When the slave sends its response, it places its own address in this address field of the response to let the master know which slave is responding.

Function field

The function code field of a message frame contains eight bits. Valid codes are in the range of 1 - 6, 15, 16 and 23. When a message is sent from a master to a slave device, the function code field tells the slave what kind of action to perform.

Examples are:

- to read the ON/OFF states of a group of inputs;
- to read the data contents of a group of parameters;
- to read the diagnostic status of the slave;
- to write to designated coils or registers within the slave.

When the slave responds to the master, it uses the function code field to indicate either a normal (error-free) response or that some kind of error occurred (called an exception response). For a normal response, the slave simply echoes the original function code. For an exception response, the slave returns a code that is equivalent to the original function code with its most significant bit set to a logic 1.

In addition to its modification of the function code for an exception response, the slave places an unique code into the data field of the response message. This tells the master what kind of error occurred, or the reason for the exception.

The master device's application program has the responsibility of handling exception responses. Typical processes are to post subsequent retries of the message, to try diagnostic messages to the slave and to notify operators. Additional information about function codes and exceptions comes later.

Data field

The data field is constructed using sets of two hexadecimal digits (8 bits), in the range of 00 to FF hexadecimal.

The data field of messages sent from a master to slave devices contains additional information which the slave must use to take the action defined by the function code. This can include items like discrete and register addresses, the quantity of items to be handled and the count of actual data bytes in the field.

For example, if the master requests a slave to read a group of holding registers (function code 03), the data field specifies the starting register and how many registers are to be read. If the master writes to a group of registers in the slave (function code 10 hexadecimal), the data field specifies the starting register, how many registers to write, the count of data bytes to follow in the data field, and the data to be written into the registers.

If no error occurs, the data field of a response from a slave to a master contains the data requested. If an error occurs, the field contains an exception code that the master application can use to determine the next action to be taken.

CRC Error checking field

The error checking field contains a 16 bit value implemented as 2 bytes. The error check value is the result of a Cyclical Redundancy Check (CRC) calculation performed on the message contents.

The CRC field is appended to the message as the last field in the message. When this is done, the low-order byte of the field is appended first, followed by the high-order byte. The CRC high-order byte is the last byte to be sent in the message. Additional information about CRC calculation are found in this manual.

Functions

Standard MODBUS function codes.

Function name	Function code
Read Coil (Bit) Status	1 (01h)
Read Input Status	2 (02h)
Read Holding Registers	3 (03h)
Read Input Registers	4 (04h)
Force Single Coil (Bit)	5 (05h)
Force Single Register	6 (06h)
Force Multiple Coils (Bits)	15 (0Fh)
Force Multiple Registers	16 (10h)
Force/Read Multiple Holding Registers	23 (17h)

Reading Input Status

Reading the status of digital information - read only.

EXAMPLE: Request digital input 2. Assuming it is not active.

Status: Modbus no = 2.

Request message.

Field name	Hex value
Slave address	01
Function	02
Start address HI	00
Start address LO	02
Number of Inputs HI	00
Number of Inputs LO	01
CRC LO	18
CRC HI	0A

Response message.

Field name	Hex value
Slave address	01
Function	02
Byte count	01
Input no.2 (02h)status	00
CRC LO	A1
CRC HI	88

Reading Holding Registers

Read the value of the analog variable information.

Example,

Asking for some Voltage, Frequency and Current. Their values are 400.0V, 60Hz and 15.5A.

400.0V, 0.1V unit - 4000 (0FA0h)

60Hz 1Hz unit - 60 (003Ch)

15.5A, 0.1A unit - 155 (009Bh)

Request message.

Field name	Hex value
Slave address	01
Function	0
Start address HI	00
Start address LO	00
Number of Registers HI	00
Number of Registers LO	03
CRC LO	05
CRC HI	CB

Response message

Field name	Hex value
Slave address	01
Function	03
Byte count	06
Reg no. 0, (0h) data HI	0F
Reg no. 0, (0h) data LO	A0
Reg no. 1, (1h) data HI	00
Reg no. 1, (1h) data LO	3C
Reg no. 2, (2h) data HI	00
Reg no. 2, (2h) data LO	9B
CRC LO	20
CRC HI	34

Reading Coil Status

Read the status of mutable digital parameters.

Example

Requesting the state of coil input (Bit) 29. Assume it is on

30 input: Modbus no = 29 (1Dh)

On = Yes = 1 Coil = 0001

1 byte of data: Byte count=01

Request message.

Field name	Hex value
Slave address	01
Function	01
Start address HI	00
Start address LO	1D
Number of Coils HI	00
Number of Coils LO	01
CRC LO	6D
CRC HI	CC

Response message.

Field name	Hex value
Slave address	01
Function	01
Byte count	01
Coil no.29 (1Dh) status	01
CRC LO	90
CRC HI	48

Reading Input Registers

Read the contents of the read-only analog information.

Example

Request the Modbus value 30011 - No. 10. Assume it is 452.0. It is long representation. 2 registers are used (30011 high word and 30012 low word)

452.0, unit 0.1 - 4520 (000011A8h).

Request message.

Field name	Hex value
Slave address	01
Function	04
Start address HI	00
Start address LO	0A
Number of Registers HI	00
Number of Registers LO	02
CRC LO	51
CRC HI	C9

Response message.

Field name	Hex value
Slave address	01
Function	04
Byte count	04
Reg no. 10 (0Ah) data HI	00
Reg no. 10 (0Ah) data LO	00
Reg no. 11 (0Bh) data HI	11
Reg no. 11 (0Bh) data LO	A8
CRC LO	F6
CRC HI	6A

Forcing Single Coil (Bit)

Set the status of a changeable digital parameter.

Example

Set a command to ON. This will cause some type of action.

Modbus no = 1 - LO address 1 (01h)

Execute = 1 - 0 Data HI = 255 (0FFh), Data LO = 00 (00h)

Request message..

Field name	Hex value
Slave address	01
Function	05
Start address HI	00
Start address LO	01
Data HI	FF
Data LO	00
CRC LO	DD
CRC HI	FA

Response message.

Field name	Hex value
Slave address	01
Function	05
Start address HI	00
Start address LO	01
Data HI	FF
Data LO	00
CRC LO	DD
CRC HI	FA

Force Multiple Coil

Set the status of several changeable digital parameters.

Example

Set one flag to ON and another to ON. This will cause some actions or change parameters. Coil n. = 0-1 Reset -> 1 // Run = 1 -> 00000011 (03h)

Request message.

Field name	Hex value
Slave address	01
Function	0F
Start address HI	00
Start address LO	00
Number of Coils HI	00
Number of Coils LO	02
Byte count	01
Coil no. 0-1 status (0000 0011B)	03
CRC LO	9E
CRC HI	96

Response message.

Field name	Hex value
Slave address	01
Function	0F
Start address HI	00
Start address LO	00
Number of Coils HI	00
Number of Coils LO	02
CRC LO	D4
CRC HI	0A

Forcing Multiple Registers

Set the contents of several changeable analog parameters.

Example

Set register 40018 (Modbus No. 17) to 25.0 (250 / 10) and 40019 (Modbus No. 18) to 55. 25.0, unit 0.1 -> -250 (00FAh) // 55, unit 1% -> 55 (0037h)

Request message.

Field name	Hex value
Slave address	01
Function	10
Start address HI	00
Start address LO	11
Number of Registers HI	00
Number of Registers LO	02
Byte count	04
Data HI reg 17 (11h)	00
Data LO reg 17 (11h)	FA
Data HI reg 18 (12h)	00
Data LO reg 18 (12h)	37
CRC LO	52
CRC HI	88

Response message.

Field name	Hex value
Slave address	01
Function	10
Start address HI	00
Start address LO	11
Number of Registers HI	00
Number of Registers LO	02
CRC LO	11
CRC HI	CD

Force/Read Multiple Register

Set and read the contents of multiple modifiable analog parameters in the same message.

Example

Set one parameter to 2 (40022 = Modbus No. 21) and another to 1 (40023 = Modbus No. 22) and read the other two. They are 1450 and 17000.

1450, unit 1 -> 1450 (05AAh)
17000, unit 1 -> 17000 (4268h)

Request message.

Field name	Hex value
Slave address	01
Function	17
Start read address HI	00
Start read address LO	03
Number of read Regs HI	00
Number of read Regs LO	02
Start write address HI	00
Start write address LO	15
Number of write Regs HI	00
Number of write Regs LO	02
Byte count	04
Data HI Reg 21 (15h)	00
Data LO Reg 21 (15h)	02
Data HI Reg 22 (16h)	00
Data LO Reg 22 (16h)	01
CRC LO	62
CRC HI	77

Response message.

Field name	Hex value
Slave address	01
Function	17
Byte count	04
Reg no. 3, (3h) data HI	05
Reg no. 3, (3h) data LO	AA
Reg no. 4, (4h) data HI	42
Reg no. 4, (4h) data LO	68
CRC LO	E8
CRC HI	85

Exception response message..

Field name	Hex value
Slave address	01
Function	84
Exception code	02
CRC LO	C2
CRC HI	C1

Exception codes.

Exc. code	Name	Description
01	Illegal function	This unit doesn't support the function code.
02	Illegal data address	The data address is not within its boundaries.
03	Illegal data value	The data value is not within its boundaries.
06	Busy	The unit is unable to perform the request at this time. Retry later.

In case of using an RS232 / RS485 Converter:

An RS485 is suitable for a multi-droop network.

In a multi-droop Modbus network, termination with resistors is required on the last slave unit of the two- or four-wire network cable.

These resistors increase noise immunity and their failure to install them compromises reliability. The network connection cables must be of good quality and shielded; the shield must be connected to ground at only one point. In networks that use two-wire cable over short distances, the use of twisted pair is acceptable.

There are two versions of converters on the market: one with a DIP switch to close the termination resistors and the other without a DIP switch or resistors. In the version without termination resistors, it is the user's responsibility to install the resistors directly on the connector cable of the last slave device in the network.

The value of these resistors must have an appropriate ohm value and must be connected between lines A / Ground and B / Ground.

Using Modbus Slave Communications

Overview:

The ZYGGOT V5F allow the serial port to act as a Modbus/RTU slave. The Modbus function supports both ASCII and RTU modes (RTU configured by factory, ASCII under request) of operation across a range of baud rates and protocol frames. Also supported is port activity status, an in-activity timer and support for call-on-exception operation.

Basic Operation:

Before the Modbus function accepts messages, the Modbus must be activated pressing F5 (keyboard) for more than 3 seconds (Toggle).

Inactivity Timer:

The Modbus function contains a timer that is reset on the reception of a valid message addressed to this function. Should communications cease between the master and this function, that timer expires which sets an Inactivity timeout bit in the status word. Once communications is reestablished, both the timer and the Inactivity timeout bit in the status word are reset. Setting the timeout value to zero (at menu 13) disables this feature.

Report-on-exception:

Report-on-exception is a method of immediately informing the master that the slave has important information pending. This method is typically used in applications where modems are used as the communication channel, and the slaves are polled for data between long intervals. Once the connection is established, the master and slave require some cooperative functionality on determining the address of the slave calling. Since this functionality is not a standardized or a part of the Modbus protocol, the Modbus function contains two alternate methods such that the one most appropriate for the master is selected.

The first method involves the slave responding to the non-standard Modbus request Get Slave Address, which is broadcasted by the master after the connection is established. Since this is just a response to a Modbus request, this method does not require that Exception Messaging be enabled. This is method used by ZYGGOT. Use of this method with a third party master can require that master to be modified to support this command. The Modbus request and response frames are presented below:

Request:

ADDR	FUNC
0	65 (41H)

Response:

ADDR	FUNC	DATA
(SLAVE ADDR)	65(41H)	(SLAVE ADDR)

The second method involves the slave sending an unsolicited response (Exception Message) to the master once the connection is established (available only by request). The specific byte pattern used for the Exception Message depends on that supported by the master. When sent, the appropriate header and checksums are inserted automatically by the Modbus function. The Byte Count acts as the trigger that starts the transmission of the response. When the Byte Count transitions from zero to a specific number, that number of bytes are sent. Once transmitted, the Modbus function responds to master requests as expected.

Master Mapping:

To access a memory point or memory flag over Modbus, the master must be configured as to the point's type and offset. This is usually accomplished with one of two methods. The first method uses the traditional addressing scheme where the high digit represents the point's type and the lower digits represent the point's offset (starting with point 1). Since only four types can be represented in this manner, the Modbus function packs several data tables into a single point type array.

The Traditional RTU Reference column below specifies the starting address of each table. The second method requires the master to be configured with the specific Modbus command and offset. The supported Modbus commands and the associated offset are also illustrated below.

Reference	Maximum Range	Modbus Reference	Modbus Command(s)	ModbusOffset
%I1	2048	10001	Read Input Status (2)	00000
%IG1	256	13001		03000
%S1	13	14001		04000
%K1	4	15001		05000
%Q1	2048	00001	Read Flag Status (1) Force Flag (5) Force Multiple Flags (15)	00000
%M1	2048	03001		03000
%T1	2048	06001		06000
%QG1	256	09001		09000
%AI1	512	30001	Read Input Register (4)	00000
%AIG1	32	33001		03000
%SR1	192	34001		04000
%Aq1	512	40001		04000
%R1	8192 (1024 Retentive)	43001	Read Holding Register (3) Load Register (6) Load Multiple Registers (16)00000	03000
%AQG1	32	46001		06000

How to Connect a MODBUS slave device.

The physical device characteristics of the particular slave device determines the communications parameters required for connection. MODBUS is a multidrop communications protocol, (software), but typical RS-232 serial connections are not. RS-232 is basically a point-to-point hardware protocol with the transmit line of one device connected to the receive line of another device. Various combinations of protocol converters and/or modems may be used to multidrop RS-232 data links. Additionally, some serial cards may be configured to support 20 mA current loop for multidrop operation.

If a single slave device is to be connected, standard RS-232 hardware may be used. Depending upon the requirements of the master device, certain control signals may be required. These are typically RTS/CTS, (pins 4&5), or DTR/DSR/DCD, (pins 6,8 & 20). The ZYGGOT supports these control signals.

Communication port buffer

The ZYGGOT firmware maintains a transmit buffer and a receive buffer. When a Send or Receive task is executed, data is transferred between the appropriate buffer and the program registers.

For a «Comm Port Transmit» element, the «TX Count» word contains the number of characters moved from the program registers to the transmit buffer. This number may be less than the requested number if the comm port buffer is full.

For a «Comm Port Receive» element, the «RX Count» word contains the number of characters moved from the receive buffer into the program area. This number may be less than the requested number if the comm port buffer contains fewer characters than requested.

Serial Port

The serial port physically present on the ZYGGOT unit is referred to as COMM1.

Handshaking

Handshaking is a method by which the end destination of a transmission can control how much and when data is sent to it.

NOTE: For the purposes of this discussion, the source end is defined as the unit that is transmitting data. The destination end is defined as the unit that actually receives the data.

The handshake is configured in the ZYGGOT V5F/TOH menu. There are five (5) possible types but only NONE, XON/XOFF and CLS/RTS are implemented in this device.

NONE -- There is no handshake. The source unit sends as many bytes of data as possible as quickly as possible for a given baud rate. No consideration is given to the capabilities of the destination end.

XON/XOFF -- (Also called software handshaking) The destination end keeps track of how many characters it has received and the size of its internal buffers. If the buffer becomes full or the unit is unable to receive any more characters, it must transmit the XOFF (transmit off) character. The source end must then stop transmitting data until a subsequent XON character is sent by the destination end.

Because there is some heavy software overhead involved, the timing of transmissions is variable. The destination must first determine that it is full and then transmit the XOFF signal. The source end must read the XOFF signal and react to it. In the meantime, several additional bytes of data may be sent. It is up to the destination end to ensure that it sends the XOFF signal soon enough so that the buffer does not overflow.

The XON and XOFF characters are predefined by the ASCII character set. XON is 11 hexadecimal or 17 decimal. XOFF is 13 hexadecimal or 19 decimal. XON/XOFF handshaking is most commonly used where only ASCII values are being sent. XON/XOFF cannot easily be used where binary data is involved, because the XON/XOFF codes are also valid binary codes.

Note that XON/XOFF handshaking usually implies a full duplex communication channel (both ends can transmit simultaneously), since the receiving end must transmit the XOFF characters at any time (including in the middle of a transmission from the source end).

The advantage of XON/XOFF handshaking is that it can be implemented using a simple and inexpensive three-wire (TX/RX/Common) cable.

HARDWARE -- Also called **RTS/CTS handshaking**. Hardware handshaking requires extra signals to be sent between the two units, so it is more expensive to implement due to the increased number of wires in the interconnect cables.

In operation, the destination end determines that it is idle and asserts its **CTS (Clear To Send)** signal. In response, the source end sends data as long as the CTS signal remains active.

Many devices have the RTS/CTS signals hardwired directly into the hardware. Thus, an inactive CTS signal from the destination end can instantly shut down the source end. These hardware operations can be very fast because no software control is required in this case. Furthermore, this form of handshaking can be used regardless of the nature of the data being transmitted, ASCII or binary encoded.

Full Duplex Multi-Drop -- In a full-duplex multi-drop situation, all available units are connected in parallel. For the receiver circuitry, this is not a problem as long as the load on the network is not excessive. All units have their receivers enabled at all times.

Every message sent by the system is somehow identified by a receiving address. All units will receive all messages. All units check the delivery address against their own address and only the unit with the matching address responds.

When a unit determines that it has something to transmit, it turns on its transmitter, sends the necessary data packet, and then turns off its transmitter.

Full Duplex Multi-drop is typically found in multi-master or peer-to-peer systems where all units have a roughly equal chance of needing to transmit a message. Often, units need to verify that the message sent was sent correctly so that the receiver is on at all times.

The advantage of this system is that many units can be connected to a simple three-wire cable (RX/RX/Common). The disadvantage of this system is the increased complexity of the firmware and software.

Half Duplex Multi-Drop -- Half-Duplex Multi-Drop operation is identical to Full-Duplex, except that the transmitting unit's receiver is disabled when the unit is transmitting.

All units keep their transmitters disabled and receivers enabled at all times, except when they need to transmit. Typically, protocols dictate that only the unit corresponding to the drop address can transmit. This unit turns on its transmitter, turns off its receiver, sends the required data packet, then disables its transmitter and enables its receiver.

Half Duplex Multi-Drop is typically found in Master/Slave systems where one unit is designated the Master and all other units are Slaves. The Master transmits a message to a Slave, then disables its transmitter. All slaves hear the message, but only the slave with the matching "drop address" will turn on its transmitter and respond.

Using RS-485 with ZYGGOT

ZYGGOT does not provide RS-485-compatible signals. You must purchase and install a third-party RS-232 to RS-485 converter or a Varixx converter.

In this mode, the transmitter is controlled by the ZYGGOT CTS signal, available on the DB-9 connector, Pin 8. When the ZYGGOT activates this signal, the converter enables its transmit section.

DATA TYPES

In ZYGGOT V5FTA, data can be stored or used in several different formats. The format used depends on how the information is to be interpreted. Typical interpretations are binary bit patterns, unsigned numbers, signed numbers, floating point values, and strings.

Tipo	Nome	Descrição
------	------	-----------

BOOL: Boolean - A single BIT. Can contain only the values '0' or '1'.

BYTE: Byte - A string of 8 consecutive bits. Byte values are used where the data value is not as important as the bit patterns (shifts and rotations).

WORD: Word - A string of 16 consecutive bits. Word values are used where the data value is not as important as the bit patterns (shifts and rotations).

DWORD: Double Word - A string of 32 consecutive bits. DWORD values are used where the data value is not as important as the bit patterns (shifts and rotations).

INT: Integer - A 16-bit signed value. Integers are used where the data value is expected to be in the range -32,768 to +32,767

SINT: Short Integer - An 8-bit signed value. Short integers are used where the data value is expected to be in the range -128 to +127. **DINT: Double Integer** A 32-bit signed value. Double integers are used where the data value is expected to be in the range -2,147,483,648 to +2,147,483,647.

UINT: Unsigned Integer - A 16-bit unsigned value. Unsigned integers are used where the data value is expected to be in the range 0 (zero) to 65,535.

USINT: Unsigned Short Integer - An 8-bit unsigned value. Unsigned short integers are used where the data value is expected to be in the range 0 (zero) to 255.

UDINT: Unsigned Double Integer - A 32-bit unsigned value. Unsigned double integers are used where the data value is expected to be in the range 0 (zero) to 4,294,967,296.

REAL Floating Point: A 32-bit value. Values are stored and operated on in IEEE single-precision (six-digit) format. Values range from -3.40282E+38 to +3.40282E+38.

STRING: A variable-length sequence of characters. Each character is represented by one byte.

Bits in word registers can be used as boolean values. In this case, Bit Offset Addressing is used to specify the Register Type, Offset, and Bit Offset for the required bit.

Using boolean registers to represent real numbers is generally inefficient.

STORAGE ORDER

32-bit values (DWORD, DINT, UDINT) occupy 32 consecutive bits of data or two (2) consecutive 16-bit registers. For example, if a DINT is defined in Register %R43, the 32-bit value is contained in both %R43 and %R44.

For 32-bit values, the data is stored low-order first. For example, if a DINT is defined in Register %R43 and contains the value "65540", (0000000000000001 0000000000000100) then Register %R43 will contain "4" and %R44 will contain "1".

Byte values (such as STRINGS) are stored high-order first. For example, to store the string "31" in Register %R43, store the HEX value 3133 (decimal 12595).

Register Types

Controllers offer a wide variety of Register Types. In most cases, the controller treats register types as if they were memory locations. The following is a list of register types implemented normally available but not all are available for the user.

%AI Analog Input

16-bit input registers used to gather analog input data such as voltages, temperatures, and speed settings coming from an attached device.

%AQ Analog Output

16-bit output registers used to send analog information such a voltages, levels or speed settings to an attached device.

%I Digital Input

Single-bit input registers. Typically, an external switch is connected to the registers.

%K Key Bit

Single-bit flags used to give the programmer direct access to any front panel keys appearing on a unit. Only the OCS series has keypads.

%Q Digital Output

Single-bit output registers. Typically, these bits are connected to an actuator, indicator light or alarm annunciator.

%R General Purpose Register

Retentive 16-bit registers.

%S System Bit

Single-bit bit coils predefined for system use.

%SR System Register

16-bit registers predefined for system use.

%T Temporary Bit

Non-retentive single-bit registers.

Bit-Mapped Addressing of 32-bit Registers

Bit-mapped addressing of 32-bit registers is not allowed. Bit offset values range from 1 to 16.

In order to access all 32 bits in a double register it is necessary to address the upper word of the register separately. Storage is such that the lower word is stored in the first (base) register, and the upper word is stored in the next consecutive register.

For example, if the 32-bit binary 0000000000000001 000000000000100 value (65540 decimal) is loaded into register %R43, %R43 contains 0000000000000100 and %R44 contains 0000000000000001. Therefore, to check Bit 17 of the DWORD stored at %R43, one must check Bit 1 of %R44, addressed as %R44.1.

Numbering Base

In ZYGGOT all offsets begin with 1 (one). 0 (zero) is not valid for register offset nor bit offset addressing.

Register offsets are thus in the range of 1 to X, where X is the maximum number of register in this model. For example, if the selected type has 2048 %R registers, they are addressed as %R01 through %R2048.

Bit Offsets are in the range of 1 to 16.

Groups of Boolean registers can be accessed as a 16-bit register. In this case, though, the Bit offset must lie on a 16-bit boundary, 1, 17, 33, etc.

MEMORY MAP FOR SERIAL AND ETHERNET COMMUNICATION TCP/IP AND HTTP

READING STATE FLAGS (Coil M) - 1 Bit (active = 1) Ofsett Padrão = 3000 Reference - 3001 (Read Only) (ACTIVE STATE)

- %M1 THM Sensor Net Comm. OK
- %M2 THM SenS. Net Comm. Error
- %M3 Clear Data
- %M4 Restart Differential Data
- %M5 On Flash (Liga Flash)
- %M6 Reading Sensors
- %M7 Off Flash (Desliga Flash)
- %M8 Reserved
- %M9 Reserved
- %M10 Reserved
- %M11 Reserved
- %M12 Reserved
- %M13 Reserved
- %M14 Reserved
- %M15 Reserved
- %M16 Reserved
- %M17 Reserved
- %M18 Reserved
- %M19 Reserved
- %M20 Reserved
- %M21 Net Mute Command
- %M22 Net Reset Command
- %M23 Diff. Read. Temp.
- %M24 Simulating Diff.
- %M30 Modbus Error
- %M32 Modbus OK
- %M42 State Alarm Active
- %M43 State Trip Active
- %M47 State Fail Active
- %M56 State Humidity Fail Active
- %M57 THM Sensor Not Respondig
- %M58 State Ozone Fail Active
- %M59 Target Fail Active
- %M60 Air Fail Active
- %M63 All Sensor OK
- %M65 Target Alarm
- %M66 Target Trip
- %M67 Air Alarm
- %M68 Air Trip
- %M69 Identify THM S. On State
- %M70 Identify THM S. Off State
- %M74 Ozone Alarm Active
- %M75 Ozone Trip Active
- %M81 DI1 Input On
- %M82 DI2 Input On
- %M83 DI3 Input On
- %M84 DI4 Input On
- %M91 Mute Input On
- %M92 Reset Input On
- %M189 Gateway Inhibited
- %M190 Gateway Output Trip ON
- %M191 Gateway Nor Programmed
- %M192 Gateway Armed
- %M193 Gateway Alarm Active
- %M194 Gateway Trip Active
- %M195 Gateway Chain Input Active
- %M196 Gateway Output 1 Active
- %M197 Gateway Output 2 Active
- %M198 Gateway Imput 1 Active
- %M199 Gateway Imput 2 Active
- %M200 Gateway Comm. Error
- %M201 Gateway Comm. OK
- %M230 Arc Sensor Not Resp. Active
- %M232 Gateway Not prog. Active
- %M233 Arc Flash Active
- %M236 Chaim Command Active
- %M241 State Group 1 Target Alarm
- %M242 State Group 1 Air Alarm
- %M243 State Group 2 Target Alarm
- %M244 State Group 2 Air Alarm
- %M245 State Group 3 Target Alarm
- %M246 State Group 3 Air Alarm
- %M247 State Group 4 Target Alarm
- %M248 State Group 4 Air Alarm
- %M249 State Group 5 Target Alarm
- %M250 State Group 5 Air Alarm
- %M251 to %M254 Reserved
- %M252 Reserved
- %M253 Reserved
- %M254 Reserved
- %M255 State Ext Fail 1 Alarm
- %M256 State Ext Fail 2 Alarm
- %M257 State Sensor Not Resp Alarm
- %M258 Reserved
- %M259 State Target Alarm
- %M260 State Target Trip
- %M261 State Air Alarm
- %M262 State Air Trip
- %M263 State Differential Alarm
- %M264 State Differential Trip
- %M265 State G1 Target Trip
- %M266 State G1 Air Trip
- %M267 State G2 Target Trip
- %M268 State G2 Air Trip
- %M269 State G3 Target Trip
- %M270 State G3 Air Trip
- %M271 State G4 Target Trip
- %M272 State G4 Air Trip
- %M273 State G5 Target Trip
- %M274 State G5 Air Trip
- %M275 State Ozone Alarm
- %M276 State Ozone Trip
- %M277 State Humidity Alarm
- %M278 State Analog 1 Alarm
- %M279 State Analog 1 Trip
- %M280 State Analog 2 Alarm
- %M281 State Analog 2 Trip
- %M282 State Analog 3 Alarm
- %M283 State Analog 3 Trip
- %M284 State Analog 4 Alarm
- %M285 State Analog 4 Trip
- %M286 to %M293 Reserved
- %M294 State System Operat. Hour
- %M295 Modbus Error Alarm
- %M296 Sensor Communication Fail
- %M297 Auto Save Target Fail
- %M298 Auto Save Air Fail
- %M299 Memory Card Error
- %M501a %M600 (THM S. Status (0=OK,1=NR))
- %M669 Identify Arc S. ON
- %M670 Identify Arc S. Off

READING/WRITING STATE FLAGS (Coil M) - 1 Bit (active = 1) Ofsett Padrão = 3000 Reference - 3001 (Read / Write)

- %M101 Plot 1 Restart
- %M102 Plot 2 Restart
- %M103 Plot 3 Restart
- %M104 Plot 4 Restart
- %M105 Plot 5 Restart
- %M106 Plot 6 Restart
- %M107 Plot 7 Restart
- %M108 Plot 8 Restart
- %M109 Plot 9 Restart
- %M110 Plot 10 Restart
- %M111 Plot 11 Restart
- %M112 Plot 12 Restart
- %M113 Plot 13 Restart
- %M114 Plot 14 Restart
- %M115 Plot 15 Restart
- %M116 Plot 16 Restart
- %M117 Plot 17 Restart
- %M118 Plot 18 Restart

MODBUS DATA TYPE	LENGHT
COIL	1 BIT
HOLDING REG	16 BIT

MODBUS DATA TYPE	FUNCTION	CODE
COIL	READ	0x01
	WRITE	0x05
HOLDING REG	READ	0x03
	WRITE	0x06

MEMORY MAP FOR SERIAL AND ETHERNET COMMUNICATION TCP/IP AND HTTP

READING STATE FLAGS (Coil M) - 1

Bit (active = 1)
Standard Offset= 3000
Reference - 3001
(Read Only)
(PROGRAMMED FAILS)

%M237 Chaim Fail
%M238 Remote 1 Command Fail
%M239 Remote 2 Command Fai
%M287 Arc Sensor N. Resp Fail
%M289 Arc Flash Alarm Fail
%M290 Arc Flash Trip Fail
%M300 Gateway Not Prog Fail
%M301 Fail Operating Hour
%M302 Fail Sensor Comm.
%M303 Fail Not Responding
%M304 Reserved
%M305 Reserved
%M306 Fail Target Alarm
%M307 Fail Target Trip
%M308 Fail Air Alarm
%M309 Fail Air Trip
%M310 Fail Differ. Alarm
%M311 Fail Analog 1 Alarm
%M312 Fail Analog 2 Alarm
%M313 Fail Analog 3 Alarm
%M314 Fail Analog 4 Alarm
%M315 Fail Analog 1 Trip
%M316 Fail Analog 2 Trip
%M317 Fail Analog 3 Trip
%M318 Fail Analog 4 Trip
%M319 Fail Ext Fail 1
%M320 Fail Ext Fail 2
%M321 Fail Differ. Trip
%M322 Fail Humidity Alarm
%M323 Spare
%M324 Fail Ozone Alarm
%M325 Fail Ozone Trip
%M331 Fail G1 Air Alarm
%M332 Fail G2 Air Alarm
%M333 Fail G3 Air Alarm
%M334 Fail G4 Air Alarm
%M335 Fail G5 Air Alarm
%M336 Fail G1 Air Trip
%M337 Fail G2 Air Trip
%M338 Fail G3 Air Trip
%M339 Fail G4 Air Trip
%M340 Fail G5 Air Trip
%M341 Fail G1 Target Alarm
%M342 Fail G2 Target Alarm
%M343 Fail G3 Target Alarm
%M344 Fail G4 Target Alarm
%M345 Fail G5 Target Alarm
%M346 Fail G1 Target Trip
%M347 Fail G2 Target Trip
%M348 Fail G3 Target Trip

LEITURAS DE DADOS (Register R)

(Inteiros 16 Bits).
Ofsett Padrão = 3000
Reference = 43001
(Read Only)

%R2001 Sensor 1 Target Temper.
to
%R2100 Sensor 100 Target Temper.

%R2126 Sensor 1 Air Temper.
to
%R2225 Sensor 100 Air Temper.

READING STATE FLAGS (Coil M) - 1

Bit (active = 1)
Standard Offset = 3000
Reference - 3001
(Read Only)

%M401 Sensor Comm. OK
%M402 Sensor Comm. Error
%M403 Sensor Net Timeout
%M404 Sensor Net Frame Parity
%M405 Sensor Net CRC Check
%M406 Sensor Net Unespect. Resp.
%M407 Sensor Net Reject Comm.
%M408 Sensor Net Reject Data
%M409 Alarm Not Acknowledged
%M410 Alarm Not Cleared
%M411 Differential Function On
%M412 Differential Warm OK
%M413 Differential First Read Done
%M414 Differential Read Valid
%M415 Reserved
%M416 Reserved
%M417 Reserved
%M418 Reserved
%M419 Reserved
%M420 Reserved
%M421 Digital Input 1 On
%M422 Digital Input 2 On
%M423 Digital Input 3 On
%M424 Digital Input 4 On
%M425 EB1: Digital Input 1
%M426 EB2: Digital Input 2
%M427 EB3: Digital Input 3
%M428 EB4: Digital Input 4
%M429 EB5: Digital Input 5
%M431 EB6: Digital Input 6
%M431 EB7: Digital Input 7
%M432 EB8: Digital Input 8
%M433 to %M440 Reserved
%M441 Digital Output 1 MUTE
%M442 Digital Output 2 RESET
%M443 Digital Output 3 D.O.3
%M444 Digital Output 4 D.O.4
%M445 EB1: AUX 1
%M446 EB2: AUX 2
%M447 EB3: AUX 3
%M448 EB4: AUX 4
%M449 EB5: AUX 5
%M450 EB6: AUX 6
%M451 EB7: AUX 7
%M452 EB8: AUX 8
%M453 to %M 460 Reserved
%M1101 to %M1140 Gateways Status

READING STATE FLAGS (Coil M) - 1

Bit (active = 1)
Standard Offset = 3000
Reference - 3001
(Read Only)

%M501 to %M625 Sensor Status (0=OK,1=NR)

STATE FLAGS (R) - 1 Bit

(Not mappable in normal protocol).
Note: Read 16 Bit Register Normally. Default Offset 3000
Reference = 43001
and test Bit 2 value.
(Read Only)

%R5001.2 Target Alarm Sensor 1 to
%R5125.2 Targe Alarm Sensor 125

%R6001.2 Target Trip Sensor 1 to
%R6125.2 Target Trip Sensor 125

%R7001.2 Air Alarm Sensor 1 to
%R7125.2 Air Alarm Sensor 125

%R8001.2 Air Trip Sensor 1 to
%R8125.2 Air Trip Sensor 125

%R1701.2 Ozone Alarm Sensor 1 to
%R1825.2 Ozone Alarm Sensor 1

%R3901.2 Ozone Trip Sensor 1 to
%R4025.2 Ozone Trip Sensor 125

%R4201.2 Humidity Alarm Sensor 1 to
%R4325.2 Humidity Alarm Sensor 125

DATA READINGS (Register R)

Standard Offset = 3000
Reference = 43001
(Read Only)

%R981 H. On at Diff Start (32 Bit)
%R987 M. On at Diff Start (16 Bit)
%R985 Total Diff Time Hour (32 Bit)
%R988 Total Diff Time Min. (16 Bit)
%R1915 Time to Warm Hour (16 Bit)
%R1913 Time to Warm Min. (16 Bit)
%R1007 Time to Restart H. (16 Bit)
%R1003 Time to Restart M. (16 Bit)
%R1081 > Target Temper. (16 Bit)
%R1082 > Air Temperat. (16 Bit)
%R1330 N. Sensors Resp. (16 Bit)
%R1333 N. Sens. Not Resp (16 Bit)
%R1079 Total Alarms (16 Bits)
%R1083 Total Trips (16 Bits)
%R3051 Analog 1 Value (16 Bit)
%R3053 Analog 2 Value (16 Bit)
%R3053 Analog 3 Value (16 Bit)
%R3054 Analog 4 Value (16 Bit)
%R1192 =1 // Unity = % (16 Bit)
%R1192 =2 // Unity = °C (16 Bit)
%R1192 =4 // Unity = °F (16 Bit)
%R4401 to %R4500 Arc Sensor Voltage (xx.xx)
%R4501 to %R4600 T. Sensor Voltage (xx.xx)
%R6401 to %R6400 Arc Flash Sequence Index

MEMORY MAP FOR SERIAL AND ETHERNET COMMUNICATION TCP/IP AND HTTP

PARAMETERS (Register R)

Menu: RELAY CONFIG
Standard Offset = 3000
Reference = 43001
(Read / Write)

%R801 Language
(0=English/1=Português/2=Espanhol)
%R879 Screen Brightness (50-100%)
%R790.2 Save Screen (0=No/1=Yes)
%R860 Save Screen Time (5-200 min)
%R881 Saving Brightness (5-50%)
%R760 - %R764 Plant (10 Bytes ASCII)
%R770 - %R774 Location (10 Bytes ASCII)
%R780 - %R784 Panel (10 Bytes ASCII)
%R809 Memory Card Error Action

PARAMETERS (Register R)

Menu: PARAMETERS CONFIG
Standard Offset = 3000
Reference = 43001
(Read / Write)

%R790.1 Centigrades / Fahrenheit (0/1)
%R802 Reset On Fail Unacknowledged
(0=No/1=Yes)
%R840 Reset On Fail Active (0=No/1=Yes)
%R803 Wait If Flash = On (0=No/1=Yes)
%R804 Air Alarm Level (0-999)
%R805 Air Trip Level (0-999)
%R942 Ozone Alarm Level (0 - 2000) ppb
%R943 Ozone Trip Level (0 - 2000) ppb
%R944 Ozone Full Scale (0 - 2000) ppb
%R806 Call Screen On Fail (0=No/1=Yes)
%R807 Call Screen On Alarm (0=No/1=Yes)
%R995 Ozone Unity (0= ppb / 1= %)
%R1010.1 Reserved
%R1010.2 Reserved

PARAMETERS (Register R)

Menu: BLOCK PROGRAMING
Standard Offset = 3000
Reference = 43001
(Read / Write)

%R811 Block 1 Start (1-100)
%R812 Block 1 End (1-100)
%R821 Block 1 Target Alarm (0-999)
%R821 Block 1Target Trip (0-999)

%R813 Block 2 Start (1-100)
%R814 Block 2 End (1-100)
%R823 Block 2 Target Alarm (0-999)
%R824 Block 2Target Trip (0-999)

%R815 Block 3 Start (1-100)
%R816 Block 3 End (1-100)
%R825 Block 3 Target Alarm (0-999)
%R826 Block 3Target Trip (0-999)

%R817 Block 4 Start (1-100)
%R818 Block 4 End (1-100)
%R827 Block 4 Target Alarm (0-999)
%R828 Block 4Target Trip (0-999)

%R819 Block 5 Start (1-100)
%R820 Block 6 End (1-100)
%R829 Block 7 Target Alarm (0-999)
%R830 Block 8Target Trip (0-999)

PARAMETERS (Register R)

Menu: MODBUS CONFIG
Standard Offset = 3000
Reference = 43001
(Read / Write)

%R841 Baud Rate (1=
9600/2=19200/4=38400)
%R842 Address (1-247)
%R843 Parity (1=None/2=Odd/4=Even)
%R844 Handshake
(1=None/2=XON/XOF/4=CTS/RTS/8=MD/Half)
%R845 Timeout (0-1023 s)
%R846 Stop Bits (1=1/2=2)
%R847 Port Mode (1=RS232)
%R848 Modbus (0=Inactive/1=Active)

PARAMETERS (Register R)

Menu: TRENDING CONFIG
Standard Offset = 3000
Reference = 43001
(Read / Write)

%R835 Scale (0-9999)
%R836 Index Mode (0=Display/1=Menu)
%R837 HMI Reset (0=Disable/1=Enable)
%R838.1 Enable Retentive (0=No/1=Yes)
%R851 Index 3A-7A (1-100)
%R852 Index 3B-7B (1-100)
%R853 Index 3C-7C (1-100)
%R854 Index 8A-12A (1-100)
%R855 Index 8B-12B (1-100)
%R856 Index 8C-12C (1-100)

PARAMETERS (Register R)

Menu: SENSORS
Standard Offset = 3000
Reference = 43001
(Read / Write)

%R810 Total THM Sensor Number (1-125)
%R833 Ozone Index (0=Same Address /
1=Show From 1)
%R891 Auto Save Target Data (0=No/1=Yes)
%R892 Auto Save Air Data (0=No/1=Yes)
%R850 Save Methode (0=Always to the Same
File/1=New File Each Start)
%R859 Save Period (10-1440 m)
%R839 Start New File (0=No/1=Yes)
%R849 Read Write Fail Action (0=None/1=Log)
%R941 Auto Save Ozone Data (0=No/1=Yes)
%R945 Total Ozone Sensor Number (1-125)

PARAMETERS (Register R)

Menu: ANALOG INPUTS
Standard Offset = 3000
Reference = 43001
(Read / Write)

%R751 - %R753 Ai1 Name (6 Bytes ASCII)
%R754 - %R756 Ai2 Name (6 Bytes ASCII)
%R757 - %R759 Ai3 Name (6 Bytes ASCII)
%R787 - %R790 Ai4 Name (6 Bytes ASCII)
%R831 Read Mode (0=%/1=Temp)
%R832 Scale (10 - 99999)

MEMORY MAP FOR SERIAL AND ETHERNET COMMUNICATION TCP/IP AND HTTP

PARAMETERS (Register R)

Menu: PROTECTIONS

Standard Offset = 3000

Reference = 43001

(Read / Write)

Opções p/ Alarm Action: (0=None / 1=Log / 2=Alarm)

Opções para Trip Action: (0=None / 1=Log / 4=Trip)

Opções p/ D. Output: (0=None / 1=D.O.3 / 2=D.O.4 / 4=Aux1 / 8=Aux2 / 16=Aux3 / 32=Aux4 / 64=Aux5 / 128=Aux6 / 256=Aux7 / 512=Aux8)

%R862 Note Respond Action
 %R863 Note Resp. D. Output
 %R864 Target Alarm Action
 %R865 Target Alarm D. Output
 %R868 Note Respond Action
 %R869 Note Resp. D. Output
 %R866 Air Alarm Action
 %R867 Air Alarm D. Output
 %R870 Air Trip Action
 %R871 Air Trip D. Output
 %R877 Sensor Comm. Fail Action
 %R878 Sensor Comm Fail D. Output
 %R857 Modbus Comm. Fail Action
 %R858 Modbus Comm. Fail Aux Output
 %R957 Ozone Alarm Action
 %R958 Ozone Alarm D. Output
 %R989 Ozone Trip Action
 %R990 Ozone Trip D. Output
 %R997 Humidity Alarm Action
 %R998 Humidity Alm D. Output
 %R1020 Differential - Execute Diff (0=Non/1=Yes)
 %873 Differential Alarm Level (0-200%)
 %874 Differential Trip Level (0-200%)
 %R1016 Differential Alarm Action
 %R1017 Differential Trip Action
 %R875 Differential Warmup Hours (0-50 h)
 %R1018 Differential Restart Period (0-10000 h) (0=No)

PARAMETERS (Register R)

Menu: TARGET ALARM LEVELS

Standard Offset= 3000

Reference = 43001

(Read / Write)

%R501 Sensor 1 Target Alarm Level (0-999)
 %R502 Sensor 2 Target Alarm Level (0-999)
 ===
 %R600 Sensor 100 Target Alarm Level (0-999)

PARAMETERS (Register R)

Menu: TARGET TRIP LEVELS

Standard Offset = 3000

Reference = 43001

(Read / Write)

%R626 Sensor 1 Target Trip Level (0-999)
 %R627 Sensor 2 Target Trip Level (0-999)
 ===
 %R725 Sensor 100 Target Trip Level (0-999)

PARAMETERS (Register R)

Menu: PROTECTIONS GROUP

Standard Offset = 3000

Reference = 43001

(Read / Write)

Opções p/ Alarm Action: (0=None / 1=Log / 2=Alarm)

Opções para Trip Action: (0=None / 1=Log / 4=Trip)

Opções p/ Aux Output: (0=None / 1=D.O.3 / 2=D.O.4 / 4=Aux1 / 8=Aux2 / 16=Aux3 / 32=Aux4 / 64=Aux5 / 128=Aux6 / 256=Aux7 / 512=Aux8)

%R901 Group 1 Target Alarm Action
 %R906 Group 1 Target Trip Action
 %R911 Group 1 Air Alarm Action
 %R916 Group 1 Air Trip Action
 %R921 Group 1 Target Alarm D. Output
 %R926 Group 1 Target Trip D. Output
 %R931 Group 1 Air Alarm D. Output
 %R936 Group 1 Air Trip D. Output
 %R902 Group 2 Target Alarm Action
 %R907 Group 2 Target Trip Action
 %R912 Group 2 Air Alarm Action
 %R917 Group 2 Air Trip Action
 %R922 Group 2 Target Alarm D. Output
 %R927 Group 2 Target Trip D. Output
 %R932 Group 2 Air Alarm D. Output
 %R937 Group 2 Air Trip D. Output

%R903 Group 3 Target Alarm Action
 %R908 Group 3 Target Trip Action
 %R913 Group 3 Air Alarm Action
 %R918 Group 3 Air Trip Action
 %R923 Group 3 Target Alarm D. Output
 %R928 Group 3 Target Trip D. Output
 %R933 Group 3 Air Alarm D. Output
 %R938 Group 3 Air Trip D. Output

%R904 Group 4 Target Alarm Action
 %R909 Group 4 Target Trip Action
 %R914 Group 4 Air Alarm Action
 %R919 Group 4 Air Trip Action
 %R924 Group 4 Target Alarm D. Output
 %R929 Group 4 Target Trip D. Output
 %R934 Group 4 Air Alarm D. Output
 %R939 Group 4 Air Trip D. Output

%R905 Group 5 Target Alarm Action
 %R910 Group 5 Target Trip Action
 %R915 Group 5 Air Alarm Action
 %R920 Group 5 Air Trip Action
 %R925 Group 5 Target Alarm D. Output
 %R930 Group 5 Target Trip D. Output
 %R935 Group 5 Air Alarm D. Output
 %R940 Group 5 Air Trip D. Output

PARAMETERS (Register R)

Menu: PROTECTIONS ANALOG

Standard Offset = 3000

Reference = 43001

(Read / Write)

Opções p/ Alarm Action: (0=None / 1=Log / 2=Alarm)

Opções para Trip Action: (0=None / 1=Log / 4=Trip)

Opções p/ Aux Output: (0=None / 1=D.O.3 / 2=D.O.4 / 4=Aux1 / 8=Aux2 / 16=Aux3 / 32=Aux4 / 64=Aux5 / 128=Aux6 / 256=Aux7 / 512=Aux8)

%R961 Analog 1 Alarm Action
 %R883 Analog 1 Alarm Level High (0-100 %)
 %R969 Analog 1 Alarm D. Output
 %R965 Analog 1 Trip Action
 %R887 Analog 1 Trip Level High (0-100 %)
 %R973 Analog 1 Trip D. Output

%R962 Analog 2 Alarm Action
 %R884 Analog 2 Alarm Level High (0-100 %)
 %R970 Analog 2 Alarm D. Output
 %R966 Analog 2 Trip Action
 %R888 Analog 2 Trip Level High (0-100 %)
 %R974 Analog 2 Trip D. Output

%R963 Analog 3 Alarm Action
 %R854 Analog 3 Alarm Level High (0-100 %)
 %R971 Analog 3 Alarm D. Output
 %R967 Analog 3 Trip Action
 %R889 Analog 3 Trip Level High (0-100 %)
 %R975 Analog 3 Trip D. Output

%R964 Analog 4 Alarm Action
 %R855 Analog 4 Alarm Level High (0-100 %)
 %R972 Analog 4 Alarm D. Output
 %R968 Analog 4 Trip Action
 %R890 Analog 4 Trip Level High (0-100 %)
 %R976 Analog 4 Trip D. Output

PARAMETERS (Register R)

Menu: PROTECTIONS EXTERNAL FAIL

Standard Offset = 3000

Reference = 43001

(Read / Write)

Opções para Alarm Action (0=None/1=Log/2=Alarm)

Opções para Trip Action (0=None/1=Log/4=Trip)

Opções p/ D. Output (0=None / 1=D.O.3 / 2=D.O.4 / 4=Aux1 / 8=Aux2 / 16=Aux3 / 32=Aux4 / 64=Aux5 / 128=Aux6 / 256=Aux7 / 512=Aux8)

%R977 External Fail 1 Action
 %R983 External Fail 1 Trip Delay (0-999 x 0,1 s)
 %R979 External Fail D. Output
 %R767 - %R769 External Fail Assign Name (6 Bytes ASCII)

%R978 External Fail 1 Action
 %R984 External Fail 1 Trip Delay (0-999 x 0,1 s)
 %R980 External Fail D. Output
 %R777 - %R779 External Fail Assign Name (6 Bytes ASCII)

GENERAL SPECIFICATIONS

OVERVIEW <ul style="list-style-type: none"> • The protocol is standard Modbus RTU over RS-485. • Sensor must be configured by an USB cable prior to communication. • Every sensor must have a unique address in the network. • Address 0 (zero) is reserved to broadcast messages to all sensors. • Registers are signed integers with 16 bits precision. • Registers have more than one address and can be accessed in more than one way in order to facilitate its utilization. • The Target temperature are always corrected by emissivity value. 																																																																													
SERIAL CONFIGURATION Baud rate: 1200; 2400; 4800; 9600; 19200; 38400; 57600; 115200 Data bits: 8 Parity: No; Even; Odd Stop bits: 0.5; 1; 1.5; 2																																																																													
ADDRESS TABLE Coil (Modbus function 01) <table border="1"> <thead> <tr> <th>Address</th> <th>Name</th> <th>Description</th> </tr> </thead> <tbody> <tr> <td>27 (0x001B)</td> <td>Blink</td> <td>Blink control: 0-off 1-on</td> </tr> <tr> <td>2560 (0x0A00)</td> <td>Term_Res</td> <td>RS-485 Termination Res. Control: 0-off 1-on</td> </tr> </tbody> </table>			Address	Name	Description	27 (0x001B)	Blink	Blink control: 0-off 1-on	2560 (0x0A00)	Term_Res	RS-485 Termination Res. Control: 0-off 1-on																																																																		
Address	Name	Description																																																																											
27 (0x001B)	Blink	Blink control: 0-off 1-on																																																																											
2560 (0x0A00)	Term_Res	RS-485 Termination Res. Control: 0-off 1-on																																																																											
HOLDING REGISTER (Modbus function 03) <table border="1"> <thead> <tr> <th>Address</th> <th>Name</th> <th>Description</th> </tr> </thead> <tbody> <tr> <td>27 (0x001B)</td> <td>Blink</td> <td>Blink control: 0-off 1-on</td> </tr> <tr> <td>2560 (0x0A00)</td> <td>Term_Res</td> <td>RS-485 Termination Resistor control: 0-off 1-on</td> </tr> <tr> <td>256 (0x0100)</td> <td>Emissivity</td> <td>Emissivity multiplier divided by 100: 0 to 200 (default 95 -> read value = measure / 0.95)</td> </tr> <tr> <td>21 (0x0015)</td> <td>User_1</td> <td>Retentive free use 1</td> </tr> <tr> <td>22 (0x0016)</td> <td>User_2</td> <td>Retentive free use 2</td> </tr> <tr> <td>23 (0x0017)</td> <td>User_3</td> <td>Retentive free use 3</td> </tr> <tr> <td>24 (0x0018)</td> <td>User_4</td> <td>Retentive free use 4</td> </tr> </tbody> </table>			Address	Name	Description	27 (0x001B)	Blink	Blink control: 0-off 1-on	2560 (0x0A00)	Term_Res	RS-485 Termination Resistor control: 0-off 1-on	256 (0x0100)	Emissivity	Emissivity multiplier divided by 100: 0 to 200 (default 95 -> read value = measure / 0.95)	21 (0x0015)	User_1	Retentive free use 1	22 (0x0016)	User_2	Retentive free use 2	23 (0x0017)	User_3	Retentive free use 3	24 (0x0018)	User_4	Retentive free use 4																																																			
Address	Name	Description																																																																											
27 (0x001B)	Blink	Blink control: 0-off 1-on																																																																											
2560 (0x0A00)	Term_Res	RS-485 Termination Resistor control: 0-off 1-on																																																																											
256 (0x0100)	Emissivity	Emissivity multiplier divided by 100: 0 to 200 (default 95 -> read value = measure / 0.95)																																																																											
21 (0x0015)	User_1	Retentive free use 1																																																																											
22 (0x0016)	User_2	Retentive free use 2																																																																											
23 (0x0017)	User_3	Retentive free use 3																																																																											
24 (0x0018)	User_4	Retentive free use 4																																																																											
INPUT REGISTER (Modbus function 04) <table border="1"> <thead> <tr> <th>Address</th> <th>Name</th> <th>Description</th> </tr> </thead> <tbody> <tr> <td>1 (0x0001)</td> <td></td> <td></td> </tr> <tr> <td>30001 (0x7531)</td> <td>Version</td> <td>Sensor version (0x0102 = 1.02)</td> </tr> <tr> <td>2 (0x0002)</td> <td></td> <td></td> </tr> <tr> <td>30002 (0x7532)</td> <td>Column_and_Sensor</td> <td>Sensor column and number (auxiliary)</td> </tr> <tr> <td>3 (0x0003)</td> <td></td> <td></td> </tr> <tr> <td>30003 (0x7533)</td> <td>Status</td> <td>Bit[15-3]: Reserved Bit[2]: Blink(0-off 1-on) Bit[1]: Termination Resistor (0-off 1-on) Bit[0]: Check (1-OK)</td> </tr> <tr> <td>4 (0x0004)</td> <td></td> <td></td> </tr> <tr> <td>30004 (0x7534)</td> <td>Target_C_10</td> <td>Target temperature in Celsius multiplied by 10 (367 = 36.7°C)</td> </tr> <tr> <td>5 (0x0005)</td> <td></td> <td></td> </tr> <tr> <td>30005 (0x7535)</td> <td>Environment_C_10</td> <td>Environment temperature in Celsius multiplied by 10 (253 = 25.3°C)</td> </tr> <tr> <td>6 (0x0006)</td> <td></td> <td></td> </tr> <tr> <td>30006 (0x7536)</td> <td>Target_F_10</td> <td>Target temperature in Fahrenheit multiplied by 10 (982 = 98.2°C)</td> </tr> <tr> <td>7 (0x0007)</td> <td></td> <td></td> </tr> <tr> <td>30007 (0x7537)</td> <td>Environment_F_10</td> <td>Environment temperature in Fahrenheit multiplied by 10 (775 = 77.5°C)</td> </tr> <tr> <td>8 (0x0008)</td> <td></td> <td></td> </tr> <tr> <td>30008 (0x7538)</td> <td>Target_C</td> <td>Target temperature in Celsius (36 = 36°C)</td> </tr> <tr> <td>9 (0x0009)</td> <td></td> <td></td> </tr> <tr> <td>30009 (0x7539)</td> <td>Environment_C</td> <td>Environment temperature in Celsius (25 = 25°C)</td> </tr> <tr> <td>10 (0x000A)</td> <td></td> <td></td> </tr> <tr> <td>30010 (0x753A)</td> <td>Target_F</td> <td>Target temperature in Fahrenheit (98 = 98°C)</td> </tr> <tr> <td>11 (0x000B)</td> <td></td> <td></td> </tr> <tr> <td>30011 (0x753B)</td> <td>Environment_F</td> <td>Environment temperature in Fahrenheit (77 = 77°C)</td> </tr> <tr> <td>12 (0x000C)</td> <td></td> <td></td> </tr> <tr> <td>30012 (0x753C)</td> <td>V_Bus_100</td> <td>Bus Tension in Volts multiplied by 100 (2341 = 23.41V)</td> </tr> </tbody> </table>			Address	Name	Description	1 (0x0001)			30001 (0x7531)	Version	Sensor version (0x0102 = 1.02)	2 (0x0002)			30002 (0x7532)	Column_and_Sensor	Sensor column and number (auxiliary)	3 (0x0003)			30003 (0x7533)	Status	Bit[15-3]: Reserved Bit[2]: Blink(0-off 1-on) Bit[1]: Termination Resistor (0-off 1-on) Bit[0]: Check (1-OK)	4 (0x0004)			30004 (0x7534)	Target_C_10	Target temperature in Celsius multiplied by 10 (367 = 36.7°C)	5 (0x0005)			30005 (0x7535)	Environment_C_10	Environment temperature in Celsius multiplied by 10 (253 = 25.3°C)	6 (0x0006)			30006 (0x7536)	Target_F_10	Target temperature in Fahrenheit multiplied by 10 (982 = 98.2°C)	7 (0x0007)			30007 (0x7537)	Environment_F_10	Environment temperature in Fahrenheit multiplied by 10 (775 = 77.5°C)	8 (0x0008)			30008 (0x7538)	Target_C	Target temperature in Celsius (36 = 36°C)	9 (0x0009)			30009 (0x7539)	Environment_C	Environment temperature in Celsius (25 = 25°C)	10 (0x000A)			30010 (0x753A)	Target_F	Target temperature in Fahrenheit (98 = 98°C)	11 (0x000B)			30011 (0x753B)	Environment_F	Environment temperature in Fahrenheit (77 = 77°C)	12 (0x000C)			30012 (0x753C)	V_Bus_100	Bus Tension in Volts multiplied by 100 (2341 = 23.41V)
Address	Name	Description																																																																											
1 (0x0001)																																																																													
30001 (0x7531)	Version	Sensor version (0x0102 = 1.02)																																																																											
2 (0x0002)																																																																													
30002 (0x7532)	Column_and_Sensor	Sensor column and number (auxiliary)																																																																											
3 (0x0003)																																																																													
30003 (0x7533)	Status	Bit[15-3]: Reserved Bit[2]: Blink(0-off 1-on) Bit[1]: Termination Resistor (0-off 1-on) Bit[0]: Check (1-OK)																																																																											
4 (0x0004)																																																																													
30004 (0x7534)	Target_C_10	Target temperature in Celsius multiplied by 10 (367 = 36.7°C)																																																																											
5 (0x0005)																																																																													
30005 (0x7535)	Environment_C_10	Environment temperature in Celsius multiplied by 10 (253 = 25.3°C)																																																																											
6 (0x0006)																																																																													
30006 (0x7536)	Target_F_10	Target temperature in Fahrenheit multiplied by 10 (982 = 98.2°C)																																																																											
7 (0x0007)																																																																													
30007 (0x7537)	Environment_F_10	Environment temperature in Fahrenheit multiplied by 10 (775 = 77.5°C)																																																																											
8 (0x0008)																																																																													
30008 (0x7538)	Target_C	Target temperature in Celsius (36 = 36°C)																																																																											
9 (0x0009)																																																																													
30009 (0x7539)	Environment_C	Environment temperature in Celsius (25 = 25°C)																																																																											
10 (0x000A)																																																																													
30010 (0x753A)	Target_F	Target temperature in Fahrenheit (98 = 98°C)																																																																											
11 (0x000B)																																																																													
30011 (0x753B)	Environment_F	Environment temperature in Fahrenheit (77 = 77°C)																																																																											
12 (0x000C)																																																																													
30012 (0x753C)	V_Bus_100	Bus Tension in Volts multiplied by 100 (2341 = 23.41V)																																																																											

GENERAL SPECIFICATIONS

OVERVIEW <ul style="list-style-type: none"> • The protocol is standard Modbus RTU over RS-485. • Sensor must be configured by an USB cable prior to communication. • Every sensor must have a unique address in the network. • Address 0 (zero) is reserved for broadcast messages to all sensors. • Registers are signed integers with 16 bits precision. • Registers have more than one address and can be accessed in more than one way in order to facilitate its utilization. • The Target temperature are always corrected by emissivity value. 																																																																													
SERIAL CONFIGURATION Baud rate: 1200; 2400; 4800; 9600; 19200; 38400; 57600; 115200 Data bits: 8 Parity: No; Even; Odd Stop bits: 0.5; 1; 1.5; 2																																																																													
ADDRESS TABLE Coil (Modbus function 01) <table border="1"> <thead> <tr> <th>Address</th> <th>Name</th> <th>Description</th> </tr> </thead> <tbody> <tr> <td>27 (0x001B)</td> <td>Blink</td> <td>Blink control: 0-off 1-on</td> </tr> <tr> <td>2560 (0x0A00)</td> <td>Term_Res</td> <td>RS-485 Termination Res. Control: 0-off 1-on</td> </tr> </tbody> </table>			Address	Name	Description	27 (0x001B)	Blink	Blink control: 0-off 1-on	2560 (0x0A00)	Term_Res	RS-485 Termination Res. Control: 0-off 1-on																																																																		
Address	Name	Description																																																																											
27 (0x001B)	Blink	Blink control: 0-off 1-on																																																																											
2560 (0x0A00)	Term_Res	RS-485 Termination Res. Control: 0-off 1-on																																																																											
HOLDING REGISTER (Modbus function 03) <table border="1"> <thead> <tr> <th>Address</th> <th>Name</th> <th>Description</th> </tr> </thead> <tbody> <tr> <td>27 (0x001B)</td> <td>Blink</td> <td>Blink control: 0-off 1-on</td> </tr> <tr> <td>2560 (0x0A00)</td> <td>Term_Res</td> <td>RS-485 Termination Resistor control: 0-off 1-on</td> </tr> <tr> <td>256 (0x0100)</td> <td>Reserved</td> <td>Reserved</td> </tr> <tr> <td>21 (0x0015)</td> <td>User_1</td> <td>Retentive free use 1</td> </tr> <tr> <td>22 (0x0016)</td> <td>User_2</td> <td>Retentive free use 2</td> </tr> <tr> <td>23 (0x0017)</td> <td>User_3</td> <td>Retentive free use 3</td> </tr> <tr> <td>24 (0x0018)</td> <td>User_4</td> <td>Retentive free use 4</td> </tr> </tbody> </table>			Address	Name	Description	27 (0x001B)	Blink	Blink control: 0-off 1-on	2560 (0x0A00)	Term_Res	RS-485 Termination Resistor control: 0-off 1-on	256 (0x0100)	Reserved	Reserved	21 (0x0015)	User_1	Retentive free use 1	22 (0x0016)	User_2	Retentive free use 2	23 (0x0017)	User_3	Retentive free use 3	24 (0x0018)	User_4	Retentive free use 4																																																			
Address	Name	Description																																																																											
27 (0x001B)	Blink	Blink control: 0-off 1-on																																																																											
2560 (0x0A00)	Term_Res	RS-485 Termination Resistor control: 0-off 1-on																																																																											
256 (0x0100)	Reserved	Reserved																																																																											
21 (0x0015)	User_1	Retentive free use 1																																																																											
22 (0x0016)	User_2	Retentive free use 2																																																																											
23 (0x0017)	User_3	Retentive free use 3																																																																											
24 (0x0018)	User_4	Retentive free use 4																																																																											
INPUT REGISTER (Modbus function 04) <table border="1"> <thead> <tr> <th>Address</th> <th>Name</th> <th>Description</th> </tr> </thead> <tbody> <tr> <td>1 (0x0001)</td> <td></td> <td></td> </tr> <tr> <td>30001 (0x7531)</td> <td>Version</td> <td>Sensor version (0x0102 = 1.02)</td> </tr> <tr> <td>2 (0x0002)</td> <td></td> <td></td> </tr> <tr> <td>30002 (0x7532)</td> <td>Column_and_Sensor</td> <td>Sensor column and number (auxiliary)</td> </tr> <tr> <td>3 (0x0003)</td> <td></td> <td></td> </tr> <tr> <td>30003 (0x7533)</td> <td>Status</td> <td>Bit[15-3]: Reserved Bit[2]: Blink(0-off 1-on) Bit[1]: Termination Resistor (0-off 1-on) Bit[0]: Check (1-OK)</td> </tr> <tr> <td>4 (0x0004)</td> <td></td> <td></td> </tr> <tr> <td>30004 (0x7534)</td> <td>Ozone_C_10</td> <td>Ozone Level (multiplied by 10 (1254 = 125.4 ppb))</td> </tr> <tr> <td>5 (0x0005)</td> <td></td> <td></td> </tr> <tr> <td>30005 (0x7535)</td> <td>Humidity_C_10</td> <td>Humidity Level (multiplied by 10 (507 = 50.7%))</td> </tr> <tr> <td>6 (0x0006)</td> <td></td> <td></td> </tr> <tr> <td>30006 (0x7536)</td> <td>Reserved</td> <td>Reserved</td> </tr> <tr> <td>7 (0x0007)</td> <td></td> <td></td> </tr> <tr> <td>30007 (0x7537)</td> <td>Reserved</td> <td>Reserved</td> </tr> <tr> <td>8 (0x0008)</td> <td></td> <td></td> </tr> <tr> <td>30008 (0x7538)</td> <td>Ozone_C</td> <td>Ozone Level (1200 = 1200 ppb)</td> </tr> <tr> <td>9 (0x0009)</td> <td></td> <td></td> </tr> <tr> <td>30009 (0x7539)</td> <td>Humidity_C</td> <td>Humidity Level (63 = 63%)</td> </tr> <tr> <td>10 (0x000A)</td> <td></td> <td></td> </tr> <tr> <td>30010 (0x753A)</td> <td>Reserved</td> <td>Reserved</td> </tr> <tr> <td>11 (0x000B)</td> <td></td> <td></td> </tr> <tr> <td>30011 (0x753B)</td> <td>Reserved</td> <td>Reserved</td> </tr> <tr> <td>12 (0x000C)</td> <td></td> <td></td> </tr> <tr> <td>30012 (0x753C)</td> <td>V_Bus_100</td> <td>Bus Tension in Volts multiplied by 100 (2341 = 23.41V)</td> </tr> </tbody> </table>			Address	Name	Description	1 (0x0001)			30001 (0x7531)	Version	Sensor version (0x0102 = 1.02)	2 (0x0002)			30002 (0x7532)	Column_and_Sensor	Sensor column and number (auxiliary)	3 (0x0003)			30003 (0x7533)	Status	Bit[15-3]: Reserved Bit[2]: Blink(0-off 1-on) Bit[1]: Termination Resistor (0-off 1-on) Bit[0]: Check (1-OK)	4 (0x0004)			30004 (0x7534)	Ozone_C_10	Ozone Level (multiplied by 10 (1254 = 125.4 ppb))	5 (0x0005)			30005 (0x7535)	Humidity_C_10	Humidity Level (multiplied by 10 (507 = 50.7%))	6 (0x0006)			30006 (0x7536)	Reserved	Reserved	7 (0x0007)			30007 (0x7537)	Reserved	Reserved	8 (0x0008)			30008 (0x7538)	Ozone_C	Ozone Level (1200 = 1200 ppb)	9 (0x0009)			30009 (0x7539)	Humidity_C	Humidity Level (63 = 63%)	10 (0x000A)			30010 (0x753A)	Reserved	Reserved	11 (0x000B)			30011 (0x753B)	Reserved	Reserved	12 (0x000C)			30012 (0x753C)	V_Bus_100	Bus Tension in Volts multiplied by 100 (2341 = 23.41V)
Address	Name	Description																																																																											
1 (0x0001)																																																																													
30001 (0x7531)	Version	Sensor version (0x0102 = 1.02)																																																																											
2 (0x0002)																																																																													
30002 (0x7532)	Column_and_Sensor	Sensor column and number (auxiliary)																																																																											
3 (0x0003)																																																																													
30003 (0x7533)	Status	Bit[15-3]: Reserved Bit[2]: Blink(0-off 1-on) Bit[1]: Termination Resistor (0-off 1-on) Bit[0]: Check (1-OK)																																																																											
4 (0x0004)																																																																													
30004 (0x7534)	Ozone_C_10	Ozone Level (multiplied by 10 (1254 = 125.4 ppb))																																																																											
5 (0x0005)																																																																													
30005 (0x7535)	Humidity_C_10	Humidity Level (multiplied by 10 (507 = 50.7%))																																																																											
6 (0x0006)																																																																													
30006 (0x7536)	Reserved	Reserved																																																																											
7 (0x0007)																																																																													
30007 (0x7537)	Reserved	Reserved																																																																											
8 (0x0008)																																																																													
30008 (0x7538)	Ozone_C	Ozone Level (1200 = 1200 ppb)																																																																											
9 (0x0009)																																																																													
30009 (0x7539)	Humidity_C	Humidity Level (63 = 63%)																																																																											
10 (0x000A)																																																																													
30010 (0x753A)	Reserved	Reserved																																																																											
11 (0x000B)																																																																													
30011 (0x753B)	Reserved	Reserved																																																																											
12 (0x000C)																																																																													
30012 (0x753C)	V_Bus_100	Bus Tension in Volts multiplied by 100 (2341 = 23.41V)																																																																											

MODBUS OVER ETHERNET TCP IP SERVER



GENERAL SPECIFICATIONS (PART 1 / 4)

MODBUS OVER ETHERNET IP SERVER COMMUNICATION WILL WORK WITH PLCs AND ALLEN BRADLEY PROTOCOL OR ALLEN BRADLEY LIKE

Maximum connection = 2 /// PORT = 44818 TCP or 2222 UDP

SEND (PRODUCED) FIRST REGISTER = %R2801 /// LAST REGISTER = %R2928 /// WORDS COUNT = 128

RECEIVE (CONSUMED) FIRST REGISTER = %R3201 /// LAST REGISTER = %R3328 /// WORDS COUNT = 128

The Status word provides Ethernet/IP connection status. The upper byte of the word

contains the Class 3 (Explicit) connection count and the lower byte contains the Class 1 (IO) connection count.

NOTE: When the Status word indicates no connections, the Consumed OCS registers contain old data

As up to 128 words are allowed in each communication, a pagination scheme is used to access all important and available data.

In this version, parameter programming via the Ethernet connection is not allowed, so the variable on the corresponding screen is permanently set to "Disabled"

However, it is allowed to send some commands via the Ethernet connection, in addition to specifying the page to be read.

IN THE PLC CONNECTION PARAMETER, USE "100" FOR THE ASSEMBLY INSTANCE INPUT WITH SIZE = 128 AND USE "101" FOR THE ASSEMBLY INSTANCE OUTPUT WITH SIZE = 128

V5L V5F VERSION

CONSUMED	Controller Tags	WRITE PAGE	FUNCTION	DATA	NOTE	WARNING
%R3201 - %3300		1 TO 16	RESERVED			
%R3301	O.Data[100]	0	MUTE	1= MUTE // 0 = DO NOTHING	SEND COMMAND MUTE TO RELAY	
%R3302	O.Data[101]	0	RESET	1= RESET // 0 = DO NOTHING	SEND COMMAND RESET TO RELAY	
%R3303	O.Data[102]	0	SAVE TARGET	1= SAVE // 0 = DO NOTHING	SAVE TARGET DATA TO MEMORY CARD	
%R3304	O.Data[103]	0	SAVE AIR	1= SAVE // 0 = DO NOTHING	SAVE AIR DATA TO MEMORY CARD	
%R3305		0	RESERVED			
%R3306		0	RESERVED			
%R3307		0	RESERVED			
%R3308		0	RESERVED			
%R3309		0	RESET DIFFERENTIAL WARM	1= RESET DIFFERENTIAL // 0 = DO NOTHING	RESET DIFFERENTIAL WITH A NEW WARM PERIOD	CAUTION
%R3310	O.Data[104]	0	RESET DIFFERENTIAL NO WARM	1= RESET DIFFERENTIAL // 0 = DO NOTHING	RESET DIFFERENTIAL WITHOUT A NEW WARM PERIOD	CAUTION
%R3311	O.Data[105]	0	RESERVED			
%R3312		0	RESERVED			
%R3313		0	RESERVED			
%R3314		0	RESERVED			
%R3315		0	RESERVED			
%R3316		0	RESERVED			
%R3317		0	RESERVED			
%R3318		0	RESERVED			
%R3319		0	RESERVED			
%R3320		0	RESERVED			
%R3321		0	RESERVED			
%R3322		0	RESERVED			
%R3323		0	RESERVED			
%R3324		0	RESERVED			
%R3325		0	RESERVED			
%R3326	O.Data[106]	0	PAGE TO WRITE	NOTE USED IS THIS VERSION	0 = DO NOTHING // 1 TO 15 SET PAGE TO BE READ	
%R3327	O.Data[107]	0	PAGE TO READ	SET PAGE FROM 0 TO 15 TO BE READ F / RELAY	NOTE USED IN THIS VERSION	
%R3328	O.Data[108]	0	WRITING DATA VALID	1= DATA TO BE WRITE = VALID // 0 = DO NOTHING		

MODBUS OVER ETHERNET TCP IP SERVER

GENERAL SPECIFICATIONS (PART 2 / 4)

PRODUCED	Controller Tags	READ PAGE	FUNCTION	DATA	NOTE	WARNING
%R2927	I.Data[126]	0 - 16	PAGE READED	0 - 16	0 = READED NONE // 1 TO 15 DATA WILL BE READED	
%R2928	I.Data[127]	0 - 16	DATA READED VALID	1 = DATA VALID // 0 = WAIT NEW DATA	CONSIDER THE DATA READED ONLY IF %R2928 = 1	
%R2801 - %R2925		1 TO 16	DATA PAGES	SEE BELOW		
%R2801 - %R2925	I.Data[0] - I.Data[125]	1	TARGET TEMPERATURES 1 TO 125	x 10 - AS READED (FORMAT XXX.X)	THE DATA NEED TO BE DIVIDED BY 10 TO INSERT THE COMA	
%R2801 - %R2925	I.Data[0] - I.Data[125]	2	AIR TEMPERATURES 1 TO 125	x 10 - AS READED (FORMAT XXX.X)	THE DATA NEED TO BE DIVIDED BY 10 TO INSERT THE COMA	
%R2801 - %R2925	I.Data[0] - I.Data[125]	3	TARGET ALARM LEVELS 1 TO 125	x 10 - AS READED (FORMAT XXX.X)	THE DATA NEED TO BE DIVIDED BY 10 TO INSERT THE COMA	
%R2801 - %R2925	I.Data[0] - I.Data[125]	4	TARGET TRIP LEVELS 1 TO 125	x 10 - AS READED (FORMAT XXX.X)	THE DATA NEED TO BE DIVIDED BY 10 TO INSERT THE COMA	
%R2801 - %R2925	I.Data[0] - I.Data[125]	5	SENSORS VOLTAGE	x 100 - AS READED (FORMAT XX.XX)	THE DATA NEED TO BE DIVIDED BY 100 TO INSERT THE COMA	
%R2801 - %R2925	I.Data[0] - I.Data[125]	6	OZONE LEVELS 1 TO 125	x 10 - AS READED (FORMAT XXX.X)		
%R2801 - %R2925	I.Data[0] - I.Data[125]	7	TARGET ALARM ACTIVE 1 TO 125	146 = ACTIVE // 0 = INACTIVE		
%R2801 - %R2925	I.Data[0] - I.Data[125]	8	TARGET TRIP ACTIVE 1 TO 125	162 = ACTIVE // 0 = INACTIVE		
%R2801 - %R2925	I.Data[0] - I.Data[125]	9	AIR ALARM ACTIVE 1 TO 125	146 = ACTIVE // 0 = INACTIVE		
%R2801 - %R2925	I.Data[0] - I.Data[125]	10	AIR TRIP ACTIVE 1 TO 125	162 = ACTIVE // 0 = INACTIVE		
%R2801 - %R2925	I.Data[0] - I.Data[125]	11	SENSOR STATUS	0 = RESPONDING // 1 = NOT RESPONDING		
%R2801 - %R2925	I.Data[0] - I.Data[125]	12	HUMIDITY LEVELS	x 10 - AS READED (FORMAT XXX.X)		
%R2801 - %R2925	I.Data[0] - I.Data[125]	13	OZONE ALARM ACTIVE 1 TO 125	146 = ACTIVE // 0 = INACTIVE		
%R2801 - %R2925	I.Data[0] - I.Data[125]	14	HUMIDITY ALARM ACTIVE 1 TO 125	146 = ACTIVE // 0 = INACTIVE		
%R2801	I.Data[0]	15	SENSORS COMM OK	0 = NOT OK // 1 = OK		
%R2802	I.Data[1]	15	SENSORS COMM NOT OK	0 = OK // 1 = NOT OK		
%R2803	I.Data[2]	15	RESERVED			
%R2804	I.Data[3]	15	RESERVED			
%R2805	I.Data[4]	15	RESERVED			
%R2806	I.Data[5]	15	RESERVED			
%R2807	I.Data[6]	15	RESERVED			
%R2808	I.Data[7]	15	OZONE ALARM ACTIVE	0 = NO // 1 = YES		
%R2809	I.Data[8]	15	OZONE TRIP ACTIVE	0 = NO // 1 = YES		
%R2810	I.Data[9]	15	HUMIDITY ALARM ACTIVE	0 = NO // 1 = YES		
%R2811	I.Data[10]	15	RESERVED			
%R2812	I.Data[11]	15	ETHERNET NOT LINKED	0 = ETHERNET LINKED // 1 = NOT LINKED		
%R2813	I.Data[12]	15	ANY FAIL ACTIVE	0 = NO // FAIL ACTIVE = 1		
%R2814	I.Data[13]	15	TARGET FAIL	0 = NO // FAIL ACTIVE = 1		
%R2815	I.Data[14]	15	AIR FAIL	0 = NO // FAIL ACTIVE = 1		
%R2816	I.Data[15]	15	ALARM ACTIVE	0 = NO // ALARM ACTIVE = 1		
%R2817	I.Data[16]	15	TRIP ACTIVE	0 = NO // TRIP ACTIVE = 1		
%R2818	I.Data[17]	15	ALARM UNACKNOWLEDGED	0 = NO // 1 = YES		
%R2819	I.Data[18]	15	ALARM UNCLEARD	0 = NO // 1 = YES		
%R2820	I.Data[19]	15	TARGET FAIL ACTIVE	0 = NO // 1 = YES		
%R2821	I.Data[20]	15	TARGET TRIP ACTIVE	0 = NO // 1 = YES		
%R2822	I.Data[21]	15	AIR ALARM ACTIVE	0 = NO // 1 = YES		
%R2823	I.Data[22]	15	AIR TRIP ACTIVE	0 = NO // 1 = YES		

MODBUS OVER ETHERNET TCP IP SERVER

GENERAL SPECIFICATIONS (PART 3 / 4)

PRODUCED	Controller Tags	READ PAGE	FUNCTION	DATA	NOTE	WARNING
%R2824	I.Data[23]	15	SENSOR NOR RESPONDING	0 = NO // 1 = YES		
%R2825	I.Data[24]	15	EXTERNAL FAIL 1 ACTIVE	0 = NO // 1 = YES		
%R2826	I.Data[25]	15	EXTERNAL FAIL 2 ACTIVE	0 = NO // 1 = YES		
%R2827	I.Data[26]	15	ANALOG 1 ALARM ACTIVE	0 = NO // 1 = YES		
%R2828	I.Data[27]	15	ANALOG 2 ALARM ACTIVE	0 = NO // 1 = YES		
%R2829	I.Data[28]	15	ANALOG 3 ALARM ACTIVE	0 = NO // 1 = YES		
%R2830	I.Data[29]	15	ANALOG 4 ALARM ACTIVE	0 = NO // 1 = YES		
%R2831	I.Data[30]	15	ANALOG 1 TRIP ACTIVE	0 = NO // 1 = YES		
%R2832	I.Data[31]	15	ANALOG 2 TRIP ACTIVE	0 = NO // 1 = YES		
%R2833	I.Data[32]	15	ANALOG 3 TRIP ACTIVE	0 = NO // 1 = YES		
%R2834	I.Data[33]	15	ANALOG 4 TRIP ACTIVE	0 = NO // 1 = YES		
%R2835	I.Data[34]	15	EXCESS LIFE ACTIVE	0 = NO // 1 = YES		
%R2836	I.Data[35]	15	DIFFERENTIAL ALARM ACTIVE	0 = NO // 1 = YES		
%R2837	I.Data[36]	15	DIFFERENTIAL TRIP ACTIVE	0 = NO // 1 = YES		
%R2838	I.Data[37]	15	RESERVED			
%R2839	I.Data[38]	15	RESERVED			
%R2840	I.Data[39]	15	G1 TARGT ALARM ACTIVE	0 = NO // 1 = YES		
%R2841	I.Data[40]	15	G2 TARGT ALARM ACTIVE	0 = NO // 1 = YES		
%R2842	I.Data[41]	15	G3 TARGT ALARM ACTIVE	0 = NO // 1 = YES		
%R2843	I.Data[42]	15	G4 TARGT ALARM ACTIVE	0 = NO // 1 = YES		
%R2844	I.Data[43]	15	G5 TARGT ALARM ACTIVE	0 = NO // 1 = YES		
%R2845	I.Data[44]	15	G1 AIR ALARM ACTIVE	0 = NO // 1 = YES		
%R2846	I.Data[45]	15	G2 AIR ALARM ACTIVE	0 = NO // 1 = YES		
%R2847	I.Data[46]	15	G3 AIR ALARM ACTIVE	0 = NO // 1 = YES		
%R2848	I.Data[47]	15	G4 AIR ALARM ACTIVE	0 = NO // 1 = YES		
%R2849	I.Data[48]	15	G5 AIR ALARM ACTIVE	0 = NO // 1 = YES		
%R2850	I.Data[49]	15	G1 TARGT TRIP ACTIVE	0 = NO // 1 = YES		
%R2851	I.Data[50]	15	G2 TARGT TRIP ACTIVE	0 = NO // 1 = YES		
%R2852	I.Data[51]	15	G3 TARGT TRIP ACTIVE	0 = NO // 1 = YES		
%R2853	I.Data[52]	15	G4 TARGT TRIP ACTIVE	0 = NO // 1 = YES		
%R2854	I.Data[53]	15	G5 TARGT TRIP ACTIVE	0 = NO // 1 = YES		
%R2855	I.Data[54]	15	G1 AIR TRIP ACTIVE	0 = NO // 1 = YES		
%R2856	I.Data[55]	15	G2 AIR TRIP ACTIVE	0 = NO // 1 = YES		
%R2857	I.Data[56]	15	G3 AIR TRIP ACTIVE	0 = NO // 1 = YES		
%R2858	I.Data[57]	15	G4 AIR TRIP ACTIVE	0 = NO // 1 = YES		
%R2859	I.Data[58]	15	G5 AIR TRIP ACTIVE	0 = NO // 1 = YES		
%R2860	I.Data[59]	15	REERVED			
%R2861	I.Data[60]	15	REERVED			
%R2862	I.Data[61]	15	REERVED			
%R2863	I.Data[62]	15	REERVED			
%R2864	I.Data[63]	15	REERVED			
%R2865	I.Data[64]	15	HUMIDITY ALARM ACTIVE	0 = NO // 1 = YES		

MODBUS OVER ETHERNET TCP IP SERVER



GENERAL SPECIFICATIONS (PART 4 / 4)

PRODUCED	Controller Tags	READ PAGE	FUNCTION	DATA	NOTE	WARNING
%R2866	I.Data[65]	15	SCREEN ALARM UNCLEARED	0 = NO // 1 = YES		
%R2867	I.Data[66]	15	SCREEN ALARM UNACKNOWLEDGED	0 = NO // 1 = YES		
%R2868	I.Data[67]	15	SCREEN ALARM ANY FAIL ACTIVE	0 = NO // 1 = YES		
%R2869	I.Data[68]	15	OZONE ALARM ACTIVE	0 = NO // 1 = YES		
%R2870	I.Data[69]	15	OZONE TRIP ACTIVE	0 = NO // 1 = YES		
%R2801	I.Data[0]	16	MAX TARGET TEMPERATURE	x 10 - AS READED (FORMAT XXX.X)	THE DATA NEED TO BE DIVIDED BY 10 TO INSERT THE COMA	
%R2802	I.Data[1]	16	MAX AIR TEMPERATURE	x 10 - AS READED (FORMAT XXX.X)	THE DATA NEED TO BE DIVIDED BY 10 TO INSERT THE COMA	
%R2803	I.Data[2]	16	MEMORY CARD STATUS	0=OK//1= UNKNOWN FORMAT//2=NO CARD// AS READED	3= NOT SUPPORTED//4=LEGAL SWAP//5=UNKNOWN//PROTECTED	
%R2804	I.Data[3]	16	DIFFERENTIAL TIME TO WARM HOUR	AS READED		
%R2805	I.Data[4]	16	DIFFERENTIAL TIME TO WARM MINUTE	AS READED		
%R2806	I.Data[5]	16	DIFFERENTIAL TIME TO RESTART HOUR	AS READED		
%R2807	I.Data[6]	16	DIFFERENTIAL TIME TO RSTRT MINUTE	AS READED		
%R2808	I.Data[7]	16	DIFFERENTIAL ON	0 = NO // 1 = YES		
%R2809	I.Data[8]	16	DIFFERENTIAL WARM OK	0 = NO // 1 = YES		
%R2810	I.Data[9]	16	DIFFERENTIAL FIRST READ OK	0 = NO // 1 = YES		
%R2811	I.Data[10]	16	DIFFERENTIAL VALID (OPERATING)	0 = NO // 1 = YES		
%R2812	I.Data[11]	16	REDING SENSOR NUMBER	AS READED (1 TO 125)		
%R2813	I.Data[12]	16	RESERVED			
%R2814	I.Data[13]	16	RESERVED			
%R2815	I.Data[14]	16	TOTAL SENSOR RESPONDING	0 TO 125		
%R2816	I.Data[15]	16	TOTAL SENSOR NOT RESPONDING	0 TO 125		
%R2817	I.Data[16]	16	TOTAL ALARM ACTIVE			
%R2818	I.Data[17]	16	TOTAL TRIP ACTIVE			
%R2819	I.Data[18]	16	RESERVED			
%R2820	I.Data[19]	16	RESERVED			
%R2821	I.Data[20]	16	RESERVED			
%R2822	I.Data[21]	16	RESERVED			
%R2823	I.Data[22]	16	REAL TIME CLOCK DAY	1 TO 31		
%R2824	I.Data[23]	16	REAL TIME CLOCK MONTH	1 TO 12		
%R2825	I.Data[24]	16	REAL TIME CLOCK YEAR			
%R2826	I.Data[25]	16	REAL TIME CLOCK HOUR	0 TO 24		
%R2827	I.Data[26]	16	REAL TIME CLOCK MINUTE	0 TO 60		
%R2828	I.Data[27]	16	REAL TIME CLOCK SECONDS	0 TO 60		
%R2829	I.Data[28]	16	RESERVED			

MODBUS OVER ETHERNET TCP IP SERVER

ETHERNET MODULE IN STUDIO 5000/LOGIX DESIGNER ALLEN BRADLEY

Steps to create an Ethernet module in a project in Studio 5000/Logix Designer – Allen Bradley PLCs / Zyggot Relays Connection. Let's consider that we have only 5 temperature sensors connected to the Relay.

1- OPEN YOUR PROJECT

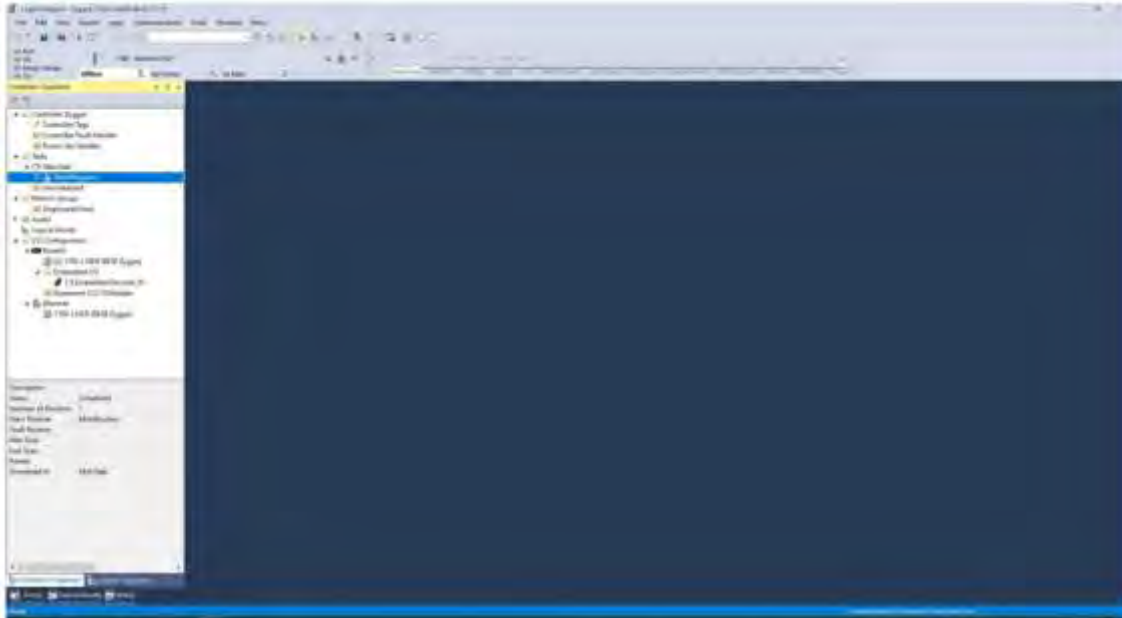

2- RIGHT CLICK ON "ETHERNET" AND THEN CLICK ON "NEW MODULE..."

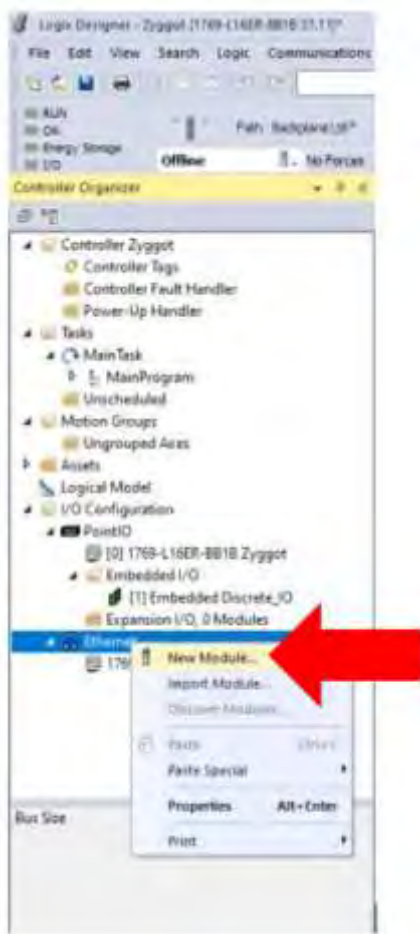

MODBUS OVER ETHERNET TCP IP SERVER

ETHERNET MODULE IN STUDIO 5000/LOGIX DESIGNER ALLEN BRADLEY

Steps to create an Ethernet module in a project in Studio 5000/Logix Designer – Allen Bradley PLCs / Zyggot Relays Connection. Let's consider that we have only 5 temperature sensors connected to the Relay.

3- IN THE “SELECT MODULE TYPE” WINDOW SELECT THE “CATALOG” TAB AND TYPE “GENERIC” IN THE SEARCH FIELD.

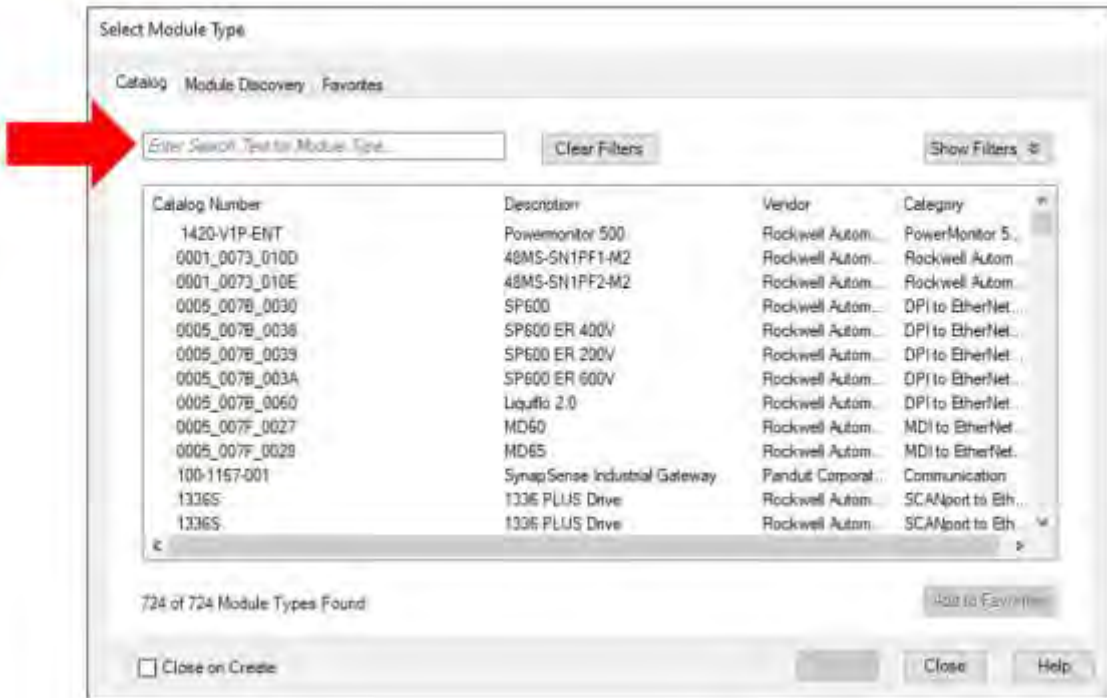

4- THEN SELECT “ETHERNET-MODULE” AND CLICK “CREATE”

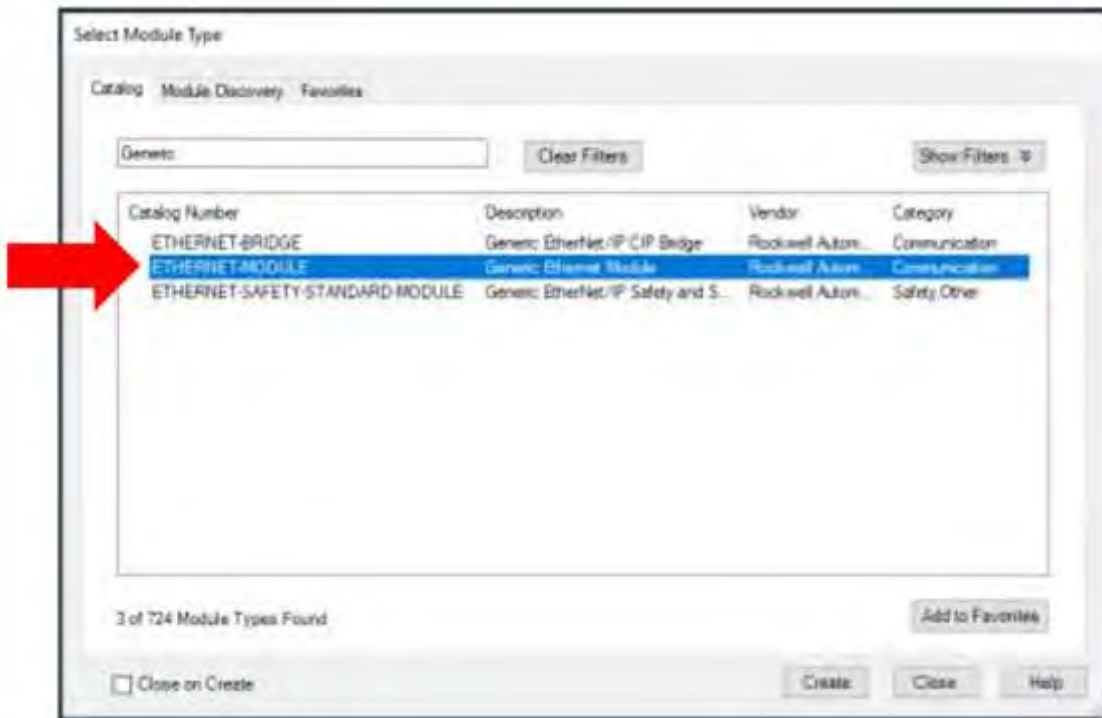

MODBUS OVER ETHERNET TCP IP SERVER

ETHERNET MODULE IN STUDIO 5000/LOGIX DESIGNER ALLEN BRADLEY

Steps to create an Ethernet module in a project in Studio 5000/Logix Designer – Allen Bradley PLCs / Zyggot Relays Connection. Let's consider that we have only 5 temperature sensors connected to the Relay.

5- IN THE "NEW MODULE" WINDOW:

- IN THE "COMM FORMAT" FIELD, CHOOSE THE "DATA - INT" OPTION
 - IN "IP ADDRESS", ENTER THE IP THAT WAS CONFIGURED IN THE ZYGGOT FTA VARIXX RELAY
 - IN "ASSEMBLY INSTANCE" OF THE INPUT, ENTER "100"
 - IN "SIZE" INPUT, ENTER "128"
 - IN "ASSEMBLY INSTANCE" OUTPUT, ENTER "101"
 - IN "SIZE" OUTPUT, ENTER "128"
 - IN "ASSEMBLY INSTANCE" CONFIGURATION, ENTER "3"
 - IN "SIZE" CONFIGURATION, ENTER "0"
- THEN CLICK "OK".

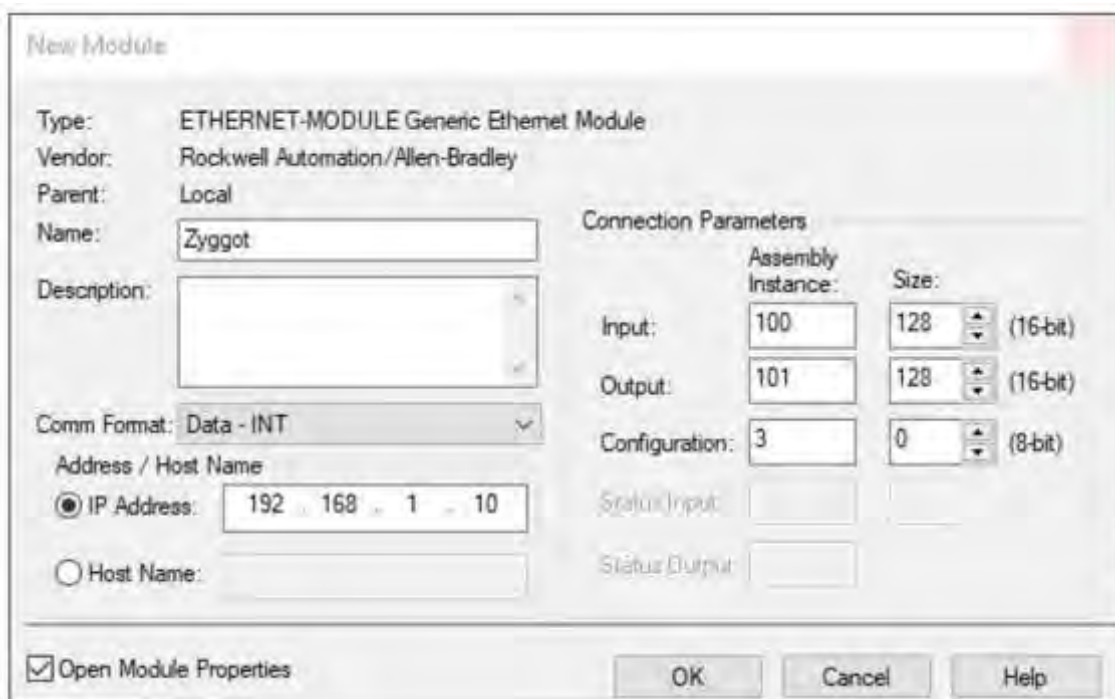

New Module

Type: ETHERNET-MODULE Generic Ethernet Module
 Vendor: Rockwell Automation/Allen-Bradley
 Parent: Local
 Name: Zyggot
 Description:
 Comm Format: Data - INT
 Address / Host Name
 IP Address: 192 . 168 . 1 . 10
 Host Name:
Connection Parameters
 Input: Assembly Instance: 100 Size: 128 (16-bit)
 Output: Assembly Instance: 101 Size: 128 (16-bit)
 Configuration: Assembly Instance: 3 Size: 0 (8-bit)
 Status Input:
 Status Output:
 Open Module Properties
 OK Cancel Help

MODBUS OVER ETHERNET TCP IP SERVER

ETHERNET MODULE IN STUDIO 5000/LOGIX DESIGNER ALLEN BRADLEY

Steps to create an Ethernet module in a project in Studio 5000/Logix Designer – Allen Bradley PLCs / Zyggot Relays Connection. Let's consider that we have only 5 temperature sensors connected to the Relay.

6- DOWNLOAD THE PROJECT TO THE PLC.

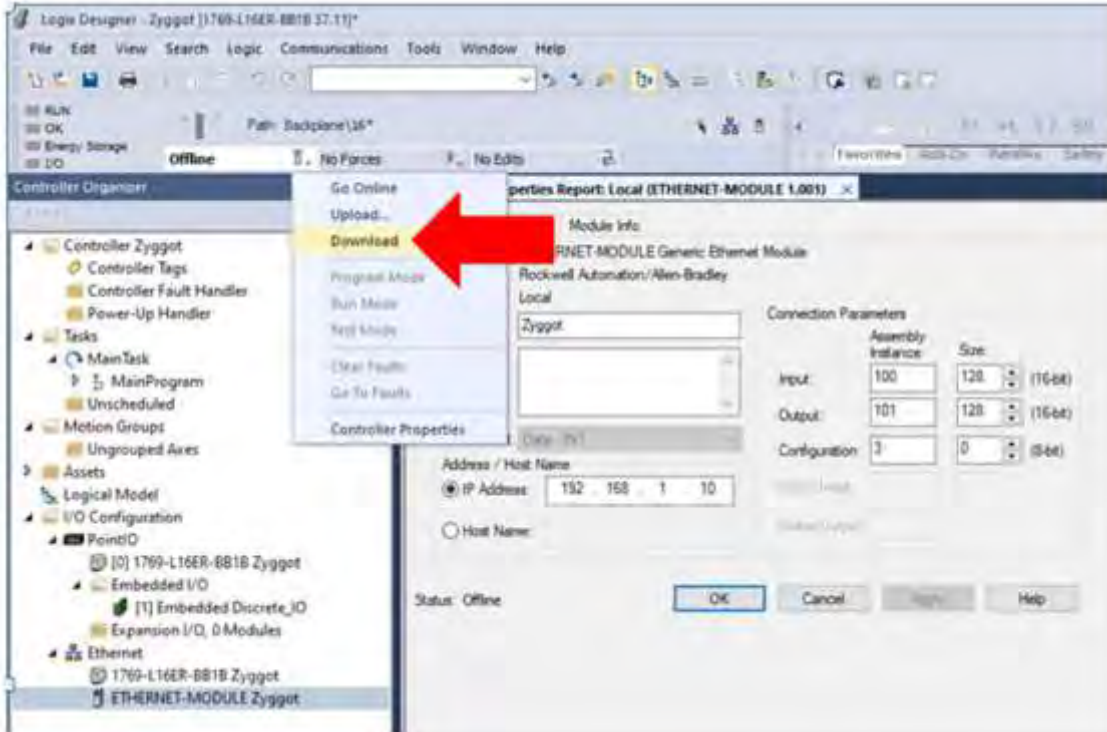

7- TESTING: READING THE TARGET TEMPERATURE OF THE 5 SENSORS CONNECTED TO THE RELAY.

7a- LEAVE THE PLC IN RUN MODE BY THE SYSTEM AND DOUBLE CLICK ON "CONTROLLER TAGS".

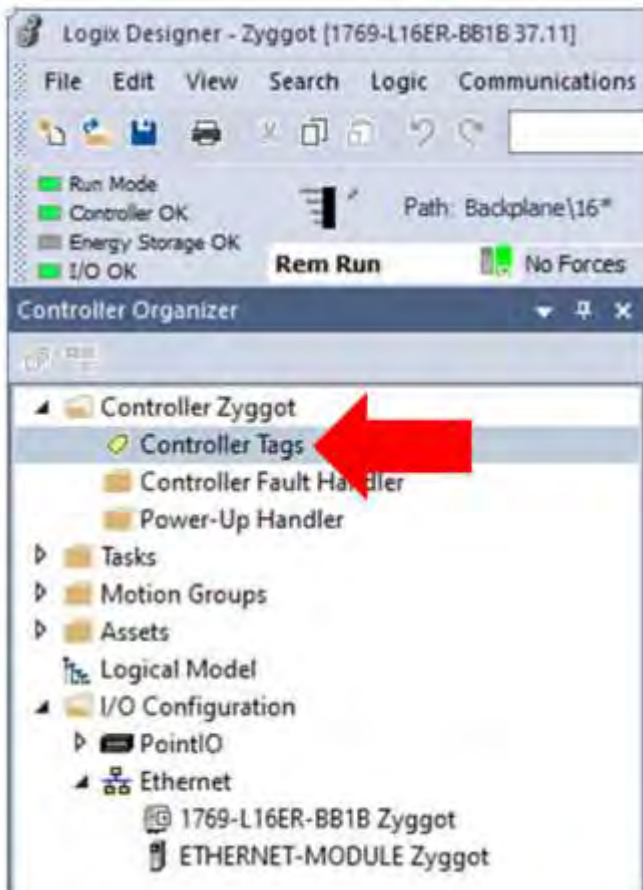

MODBUS OVER ETHERNET TCP IP SERVER

ETHERNET MODULE IN STUDIO 5000/LOGIX DESIGNER ALLEN BRADLEY

Steps to create an Ethernet module in a project in Studio 5000/Logix Designer – Allen Bradley PLCs / Zyggot Relays Connection. Let's consider that we have only 5 temperature sensors connected to the Relay.

7b- SELECT AS SHOWN.

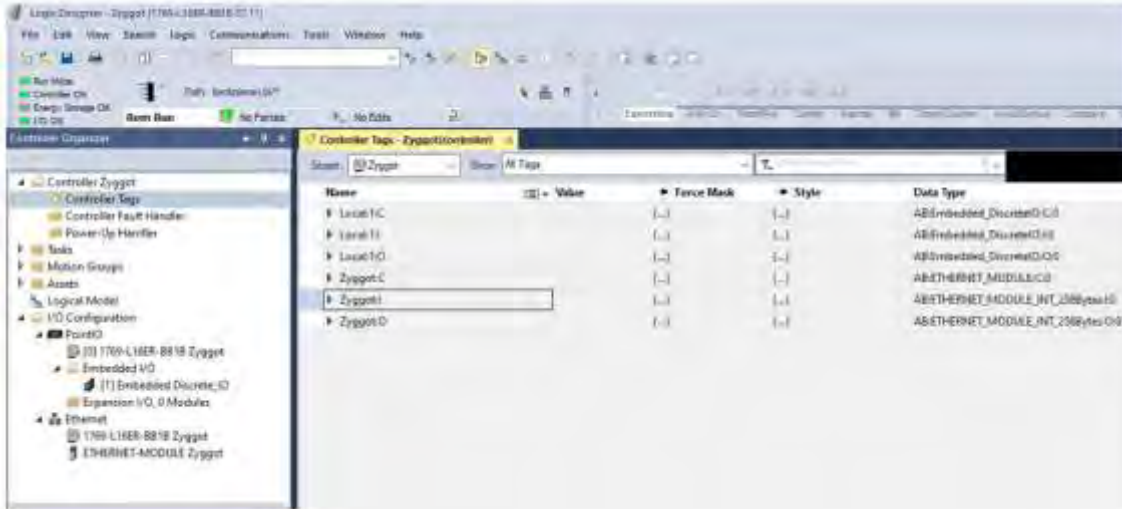

7c- FIND THE OUTPUT RECORD "...0.DATA[126]" (%R3327) AND MAKE SURE IT HAS THE VALUE "1," OTHERWISE, ASSIGN IT THE VALUE "1" (THIS IS WHICH PAGE 1 IS SELECTED, THIS «PAGE» IS REFERENT TO THE SYSTEM TARGET TEMPERATURE VALUES).

Name	Value	Force Mask	Style	Data Type
Zyggot:O.Data[120]	0			Decimal INT
Zyggot:O.Data[121]	0			Decimal INT
Zyggot:O.Data[122]	0			Decimal INT
Zyggot:O.Data[123]	0			Decimal INT
Zyggot:O.Data[124]	0			Decimal INT
Zyggot:O.Data[125]	0			Decimal INT
Zyggot:O.Data[126]	1			Decimal INT
Zyggot:O.Data[127]	0			Decimal INT

7d - NOW FIND THE INPUT REGISTER "...I.DATA[0]" (%R2801), DIVIDING THE RECEIVED VALUE BY 10, WE WILL HAVE THE TARGET TEMPERATURE OF SENSOR 1. IN THE REGISTER "...I.DATA[1]" (%R2802) WE HAVE THE TARGET TEMPERATURE OF SENSOR 2 AND SO ON. IN THE IMAGE BELOW WE HAVE THE TEMPERATURE VALUES OF THE FIRST 5 SENSORS READ BY THE RELAY (NOT YET DIVIDED BY 10).

Name	Value	Force Mask	Style	Data Type
Local:I:C				AB:Embedded_Discretel:0:C:0
Local:I:I				AB:Embedded_Discretel:0:I:0
Local:I:O				AB:Embedded_Discretel:0:O:0
Zyggot:C				AB:ETHERNET_MODULE:C:0
Zyggot:I				AB:ETHERNET_MODULE_INT_256Bytes:0
Zyggot:I.Data			Decimal	INT[128]
Zyggot:I.Data[0]	233		Decimal	INT
Zyggot:I.Data[1]	232		Decimal	INT
Zyggot:I.Data[2]	224		Decimal	INT
Zyggot:I.Data[3]	211		Decimal	INT
Zyggot:I.Data[4]	245		Decimal	INT
Zyggot:I.Data[5]			Decimal	INT
Zyggot:I.Data[6]	0		Decimal	INT
Zyggot:I.Data[7]	0		Decimal	INT
Zyggot:I.Data[8]	0		Decimal	INT
Zyggot:I.Data[9]	0		Decimal	INT

BT SENSOR TEST REPORT

CAN BE EXTENDED TO THE TUBULAR SENSOR BY SIMILARITY

Zyggot BT Sensor Analysis Report

Date: 10/04/2022

Objetive

Check the reliability of temperature measurements using the Zyggot BT sensor

Used equipments

Equipment	Fabricante	Modelo	Número de Série
4 CH 100MHz Oscilloscope	Keysight	DSOX 3014T	MY55120213
Infrared Thermometer Calibrator	Fluke	9133	CO6729
DC Power Supply 24V 60W	Varixx	VPS6024	VFE22132
Zyggot Relay Model V5L/V5F	Varixx	VZX/B1/U	SRT1003315
125 Zyggot Temperature Sensor Model V5L/V5F	Varixx	ZSB/M/60/120	SBT1037459 ao SBT1037584

Temperature ramp response curve

Measurement performed using a Zyggot BT sensor pointed at the target ranging from 0 to 120°C

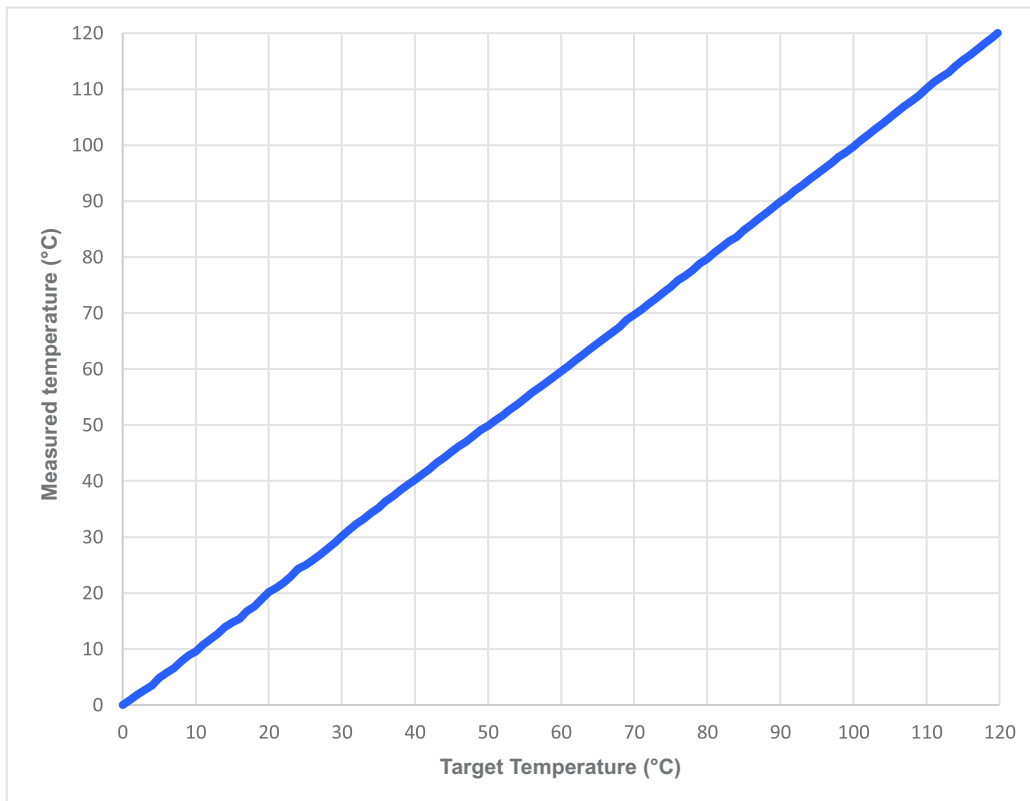

Maximum absolute error: 0.6°C
Standard Deviation: 0.23°C

Measurement distribution of 125 sensors targeting at 80°C

Measurement carried out with 125 sensors connected in a network in the Zyggot relay and with a fixed target at 80°C

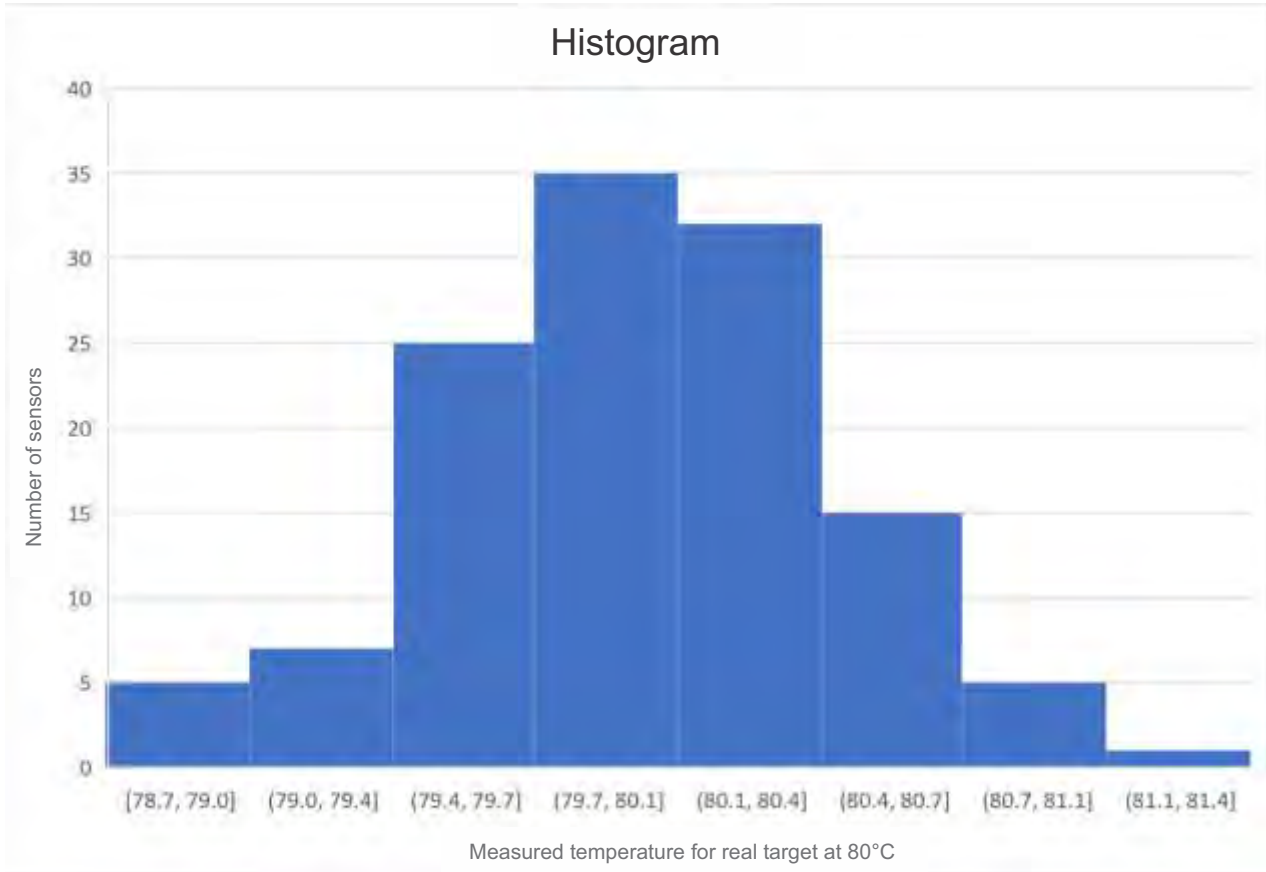

Maximum absolute error: 1.3°C

Standard Deviation: 0.48°C

ABOUT VARIXX

For over 40 years, Varixx has pursued its vocation for developing high-tech products and focuses its efforts on serving the industrial market with quality and speed. Our know-how in power electronics has allowed us to offer the market a wide range of products that have become known for their long service life and reliability. We were the creators of the global online thermography market, with the Zyggot line, which is becoming a global reference in the market for temperature monitoring and diagnostics and arc flash detection in electrical systems in general.

Our product portfolio also includes LED luminaires from our ONNO division, developed and manufactured 100% in Brazil with cutting-edge technology. Varixx values the introduction of innovative concepts worldwide.

AREAS OF ACTIVITY

- ✓ **MANUFACTURERS OF GENERATOR MACHINES AND SYNCHRONOUS MOTORS**
Static Exciters, Control Box Controllers, Low and Medium Voltage Soft Starters, Semiconductors
- ✓ **PRODUCTION OF ALUMINUM AND HYDROGEN / OXYGEN**
High Current Rectifiers, Solid State Contactors, Smart Relay for CCM, Online Thermography System and Arc Flash Detection and Onno LED Luminaires.
- ✓ **BASE INDUSTRY, MINING AND STEEL INDUSTRY**
Smart Relays for CCMs, Low and Medium Voltage Soft Starters, Solid State Contactors, AC/DC Converters for electromagnets, High Current Rectifiers, Online Thermography System, Arc Flash Detection and Protection and Onno LED Luminaires.
- ✓ **OIL COMPANIES**
Smart Relays for CCMs, Static Excitation, Low and Medium Voltage Soft Starters, Solid State Contactors, Online Thermography System, Arc Flash Detection and Protection and Onno LED Luminaires.
- ✓ **ELECTRIC PANEL ASSEMBLERS**
Smart Relays for CCMs, Online Thermography, Arc Flash Detection and Protection System, Semiconductors, Power Supplies and Onno LED Luminaires.

Why ZYGGOT Thermography And Arc Flash Protection?



SINGLE CABLE / EASY TO INSTALL



PREDICTIVE / DIFFERENTIAL PROTECTION



EFFECTIVE PROTECTION AGAINST ARC DESTRUCTION



WORLDWIDE UNIQUE BY UV DETECTION / NO CURRENT READINGS REQUIRED



DOES NOT NEED CONVENTIONAL THERMOGRAPHY / ALSO MEASURES AIR TEMP.



WITHOUT CONTACT / WITH NETWORK COMMUNICATION

LEARN MORE!

ZYGGOT ARC FLASH SYSTEM

- ✓ **Low Cost // Up to 100 sensors per gateway.**
- ✓ **Innovative in the market // Faster (<300 uS versus up to 500 mS)**
- ✓ **Ultraviolet arc detection**
- ✓ **Does not operate with ambient light (False Alarm)**
- ✓ **No need for current readings**

varixx

ALWAYS INNOVATING

www.varixx.com.br
vendas@varixx.com.br
+55 (19) 3424-4000
+55 (19) 3301-6900

R. Felipe Zaidan Maluf, 450
Distrito Industrial Unileste
Piracicaba-SP. CEP: 13422-190



@Varixxbrasil



@varixxcompany



Varixx Indústria Eletrônica



www.varixx.com
www.varixx.com.br

Representative/Distributor:

VARIXX USA

2229 Allen Parkway, Suite 200
+1 832-871-5700
Houston - Texas, 77019

VARIXX WORLDWIDE

MORE THAN 20 BRANCHES,
DISTRIBUTORS AND REPRESENTATIVE
OFFICES WORLDWIDE



ZYGGOT THERMOGRAPHY